

Notes:-

- The legends are from the Transport Medium alphabet at the 'x'-heights shown.
- Details of the diversion route and aeroplane symbols are given on drawings S56 and S30 respectively.
- The outlines of the tiles do not form part of the sign.
- The colours are as follows:-  
 Background \_\_\_\_\_ Green  
 Border, route symbol \_\_\_\_\_ White  
 Legend \_\_\_\_\_ White (Transport Medium)  
 Route number \_\_\_\_\_ Yellow (Transport Medium)  
 Diversion route symbol:-  
 Symbol \_\_\_\_\_ Black  
 Background \_\_\_\_\_ Yellow
- The illumination of the sign must accord with the requirements of the current 'Traffic Signs Regulations and General Directions'.
- The 'x'-heights shown are given in millimetres, all other dimensions are given in stroke widths (i.e.  $1s/w = 1/4x'$ -height).
- The sign is designed in accordance with the current design rules.
- The order of languages may be reversed if required.

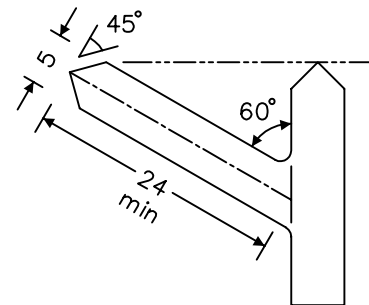
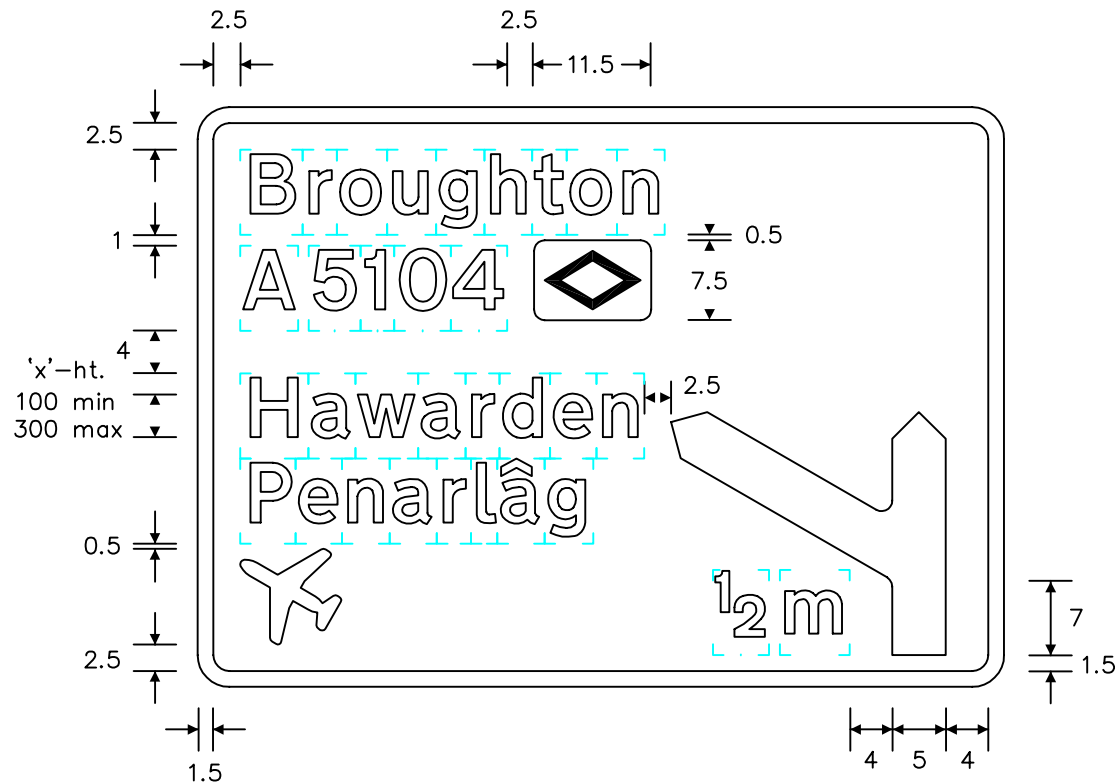

REVISIONS	
1.	Redesigned, no. chgd. from WO/WM702 3.3.97
2.	Redrawn & notes amended 14.8.00
3.	Redrawn & notes amended 29.3.04
4.	Notes amended 16.4.07
Before using this drawing, confirm with RNM3 Division that it has not been superseded.	
Drn. A.T.I.	Appd.
Chkd.	Appl. date 28.11.83
Issue: 16.4.07	
Scale: Photo-reduced	
Title Primary Route Directional Sign (Map-type)	
GRADE SEPARATED JUNCTION 1/2 MILE AHEAD WITH ANOTHER PRIMARY ROUTE WHICH LEADS TO AN AIRPORT AND WHICH FORMS PART OF AN EMERGENCY DIVERSION ROUTE	
WELSH ASSEMBLY GOVERNMENT	
Drwg. no.	WAG/P 2011