

**Ffermio Bro:
Farming in Designated
Landscapes**

**Payment Rates and Technical
Specifications
Tranche 1**

Standard Ffermio Bro payment rates will continue to be aligned with payment rates for other Welsh Government schemes. Welsh Government is undertaking an exercise to review existing and develop new payment rates for the new SFS. This is expected to be complete during 2026. This document sets out an initial tranche ('Tranche 1') of some of the most common items, where rates have already been reviewed and published. During 2026, additional tranches will be published as they are developed by Welsh Government

Contents

Ladder Stile.....	4
Timber Bridle Gate and Posts	5
Timber Kissing Gate and Posts	6
Wooden Stiles.....	7
Badger Gate.....	8
Piped Water Supply	9
Water Gate.....	10
Water Troughs	12
Post and Rail Fencing	13
Post and Wire Fencing.....	14
Timber Field Gates (Hardwood)	16
Timber Field Gates (Softwood).....	17
Parkland Tree Stock Guards	18
Tree Shelter (60cm With Stake)	21
Trees - Standards	22
Trees and Shrubs (Transplants).....	25
Trees and Shrubs - Whips.....	28
Sabre Planting	32
Spiral Rabbit Guards.....	34
New Hedge Planting	34
Hedge Coppicing and Gapping Up.....	36
Hedge Laying.....	39
Cross Drains	41
Kerbing	43
Sleeping Policemen	44
Rainwater Goods (Guttering)	45
Rainwater Goods – Downpipe.....	46
New Hedge Planting for Pollinators	48
Dry Stone Wall Restoration	49
Earth Bank Restoration	52
Stone Faced Earth Bank Restoration	54

Slate Fence Restoration.....	56
Top Wiring on Stone Walls.....	57
Fruit Trees Plus Guard and Stake.....	58
Maintenance of Gateways with Hardcore.....	59
Post and Wire Fencing with Netting.....	60
Supplement for Rabbit Fence Netting.....	62
In-Ditch Wetland.....	63
Soft Engineering of River Banks.....	66
Pond Restoration.....	72
Bramble/Scrub Control.....	75
Bracken Control.....	66
Mixed Leys.....	727
Standard Item Review.....	79

Version: 1

Issue Date: April 2026

Issued By: Welsh Government

© Crown Copyright 2025 ISBN Number: 978-1-83745-233-0

Ladder Stile

Item Code: L001

Payment Rate: £259.45 each

This technical note describes the minimum standard of work required in order to receive payments for 'Ladder Stile'. Any variation must be approved by the Welsh Government prior to starting the work.

Ladder stiles are used to allow walkers to cross walls and banks.

You must adhere to the following:

- Construct the ladder stile from pressure treated softwood or hardwood.
- Use timber with dimensions no less than those shown in the diagram. The steps can either be rebated into the 'A' frames or supported by extra pieces of timber. Secure the stile on both sides by burying the ends of the 'A' frame to a sufficient depth in the ground and anchoring them with stobs as shown.
- Construct a platform at the top of the stile to cross over wide walls or banks if needed.
- Ensure the gate is compliant with BS5709:2006, as amended. The least restrictive furniture must be used as possible, e.g. a gate is less restrictive than a stile.

Do not:

- Use ladder stiles on a Public Right of Way (PROW) unless approved by the Welsh Government.
- Use concrete to secure timber supports in the ground.
- Reduce the size of wide walls or banks to enable the ladder to span the boundary. Construct a platform at the top of the stile if needed.

Requirements and guidance in addition to the specifications above:

- Best practice is to bury the ends of the 'A' frame at least 30cm into the ground to anchor the stile.

Example of a step ladder stile

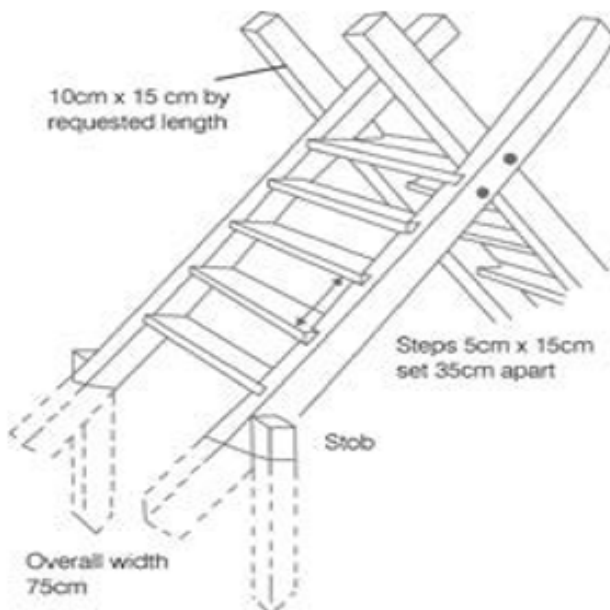

Timber Bridle Gate and Posts

Item Code: L002

Payment Rate: £301.39 each

This technical note describes the minimum standard of work required to receive payments for 'Timber Bridle Gate and Posts'. Any variation must be approved by the Welsh Government prior to starting the work.

Bridle gates are used to allow access for walkers and horse riders.

You must adhere to the following:

- Install Timber Bridle Gates and Posts constructed from either pressure treated softwood or hardwood.
- Install gates that are at least 1.5m wide and 1.3m high. Ensure there is sufficient space on one side of the gate for the horse to stand while the gate is being opened.
- Use a ready-made gate, or construct a gate. All gate timbers must meet the following dimensions:
 - Uprights should be at least 10cm x 7.5cm in cross section.
 - All rails should be 7.5cm x 2.5cm in cross section except the top rail which should be 10cm x 7.5cm.
- Hang the gate so that it can be opened from both directions.
- Fit latches that allow the gate to be opened without the rider dismounting.
- Ensure that all post timbers must meet the following dimensions;
 - Hanging posts must be at least 15cm diameter
 - Shutting posts must be at least 12cm in diameter
 - Posts must be set into the ground to a sufficient depth to ensure stability.

Do not:

- Install bridle gates and posts on Public Rights of Way (PRoW) unless approved by the Welsh Government.
- Use concrete to secure posts in the ground, as it can lead to rotting of posts at ground level.

Requirements and guidance in addition to the specifications above:

- Use an 'extended' or 'drop over' latch to allow gate to be opened without rider dismounting.
- In areas prone to vandalism, top hook can be reversed to prevent the gate being lifted off.
- Best practice is to set the posts at least 70cm into the ground to ensure stability.

Example of a timber bridle gate

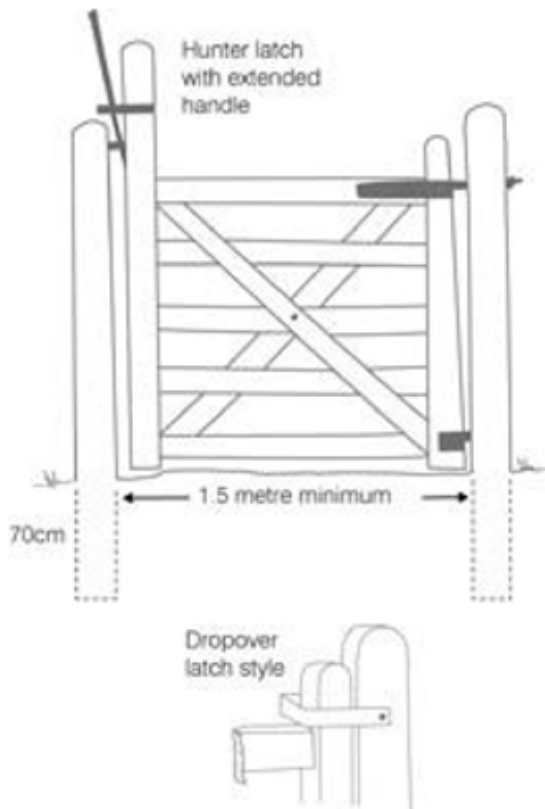

Timber Kissing Gate and Posts

Item Code: L003

Payment Rate: £362.00 each

This technical note describes the minimum standard of work required to receive payments for Timber Kissing Gate and Posts. Any variation must be approved by the Welsh Government prior to starting the work.

Kissing gates are used to allow walkers to cross field boundaries.

You must adhere to the following:

- Install Timber Kissing Gates and Posts constructed from either pressure treated softwood or hardwood.
- Install a kissing gate that is stock-proof with the gate in any position, yet allowing free passage for pedestrians.
- Ensure that the kissing gate is an effective barrier against motorcycles and horses.
- Use a ready-made gate, or construct a gate. All gates must meet the following dimensions;
 - The gate must be 1.2m wide and 1.2m high.
 - A 1m cylinder, must be able to pass through. Note that the 'throat' dimension (the narrowest space to pass through when the gate is opened) must be at least 1m.
- Ensure that post and rails meet the following dimensions;
 - Uprights should be at least 10cm x 7.5cm in cross section.
 - Rails should be 7.5cm x 2.5cm in cross section except top rail which should be 10cm x 7.5cm.

- Hanging posts must be at least 15cm diameter.
- Shutting posts must be at least 12cm in diameter.
- Posts must be set into the ground to a sufficient depth to ensure stability.
- Hang the gate so that the gate hooks are 'offset' by 3cm. This will cause the gate to close against one of the side posts when released.
- Ensure the gate is compliant with BS5709:2006, as amended. The least restrictive furniture must be used as possible e.g. a gate is less restrictive than a stile.

Do not:

- Use concrete to secure posts in the ground, as it can lead to rotting of posts at ground level.
- Use any barbed wire on the kissing gate.

Requirements and guidance in addition to the specifications above:

- For added protection against stock, a self-closing latch can be fitted.
- In areas prone to vandalism, top hook can be reversed to prevent gate being lifted off.
- Best practice is to set the posts at least 70cm into the ground to ensure stability.

Example of a timber kissing gate

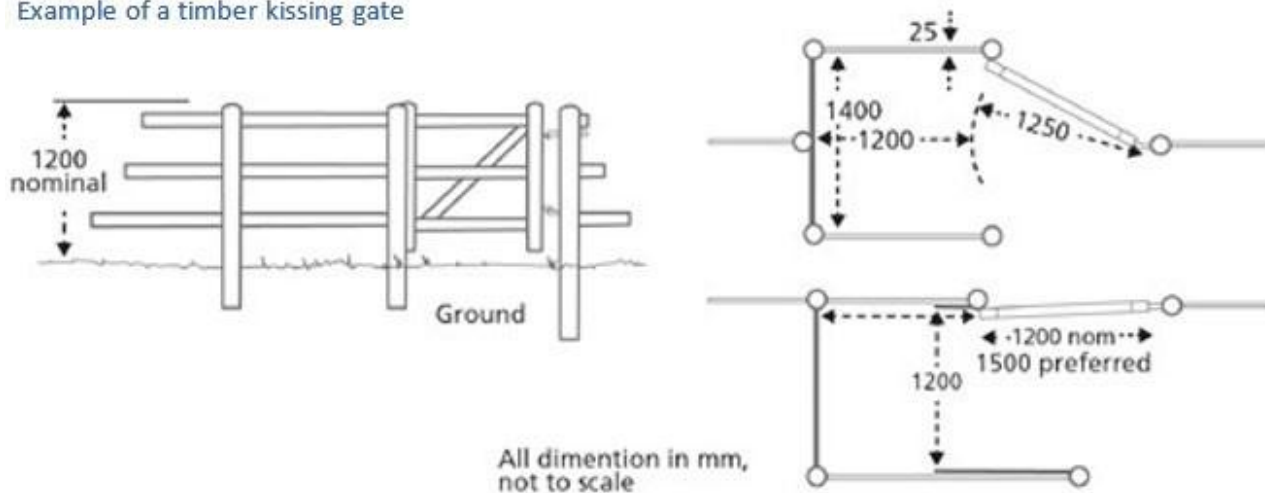

Wooden Stiles

Item Code: L004

Payment Rate: £125.01 each

This technical note describes the minimum standard of work required in order to receive payments for 'Wooden Stiles'. Any variation must be approved by the Welsh Government prior to starting the work.

Wooden stiles are used to allow walkers to cross field boundaries.

You must adhere to the following:

- Install wooden stiles constructed from either pressure treated softwood or hardwood.
- Use a ready-made stile kit, or construct a stile. For both narrow and wide stiles, they must meet the following dimensions;
- Step width should be 200mm
- Hand posts should be 70 to 100mm diameter or across faces

- Posts should be vertical to 1 in 30
- Steps should level in all directions to 1 in 30.
- Install a third step on the downhill side on a steep slope if needed. This step must be twice the width of a standard step and the 300mm step height rule applies.
- Ensure the stile is compliant with BS5709:2006, as amended. The least restrictive furniture must be used as possible e.g. a gate is less restrictive than a stile.

Do not:

- Allow the step tread boards to touch the cross-rails of the stile as a see-saw effect may develop, making the stile unsafe to use.
- Use posts as straining posts for fencing.

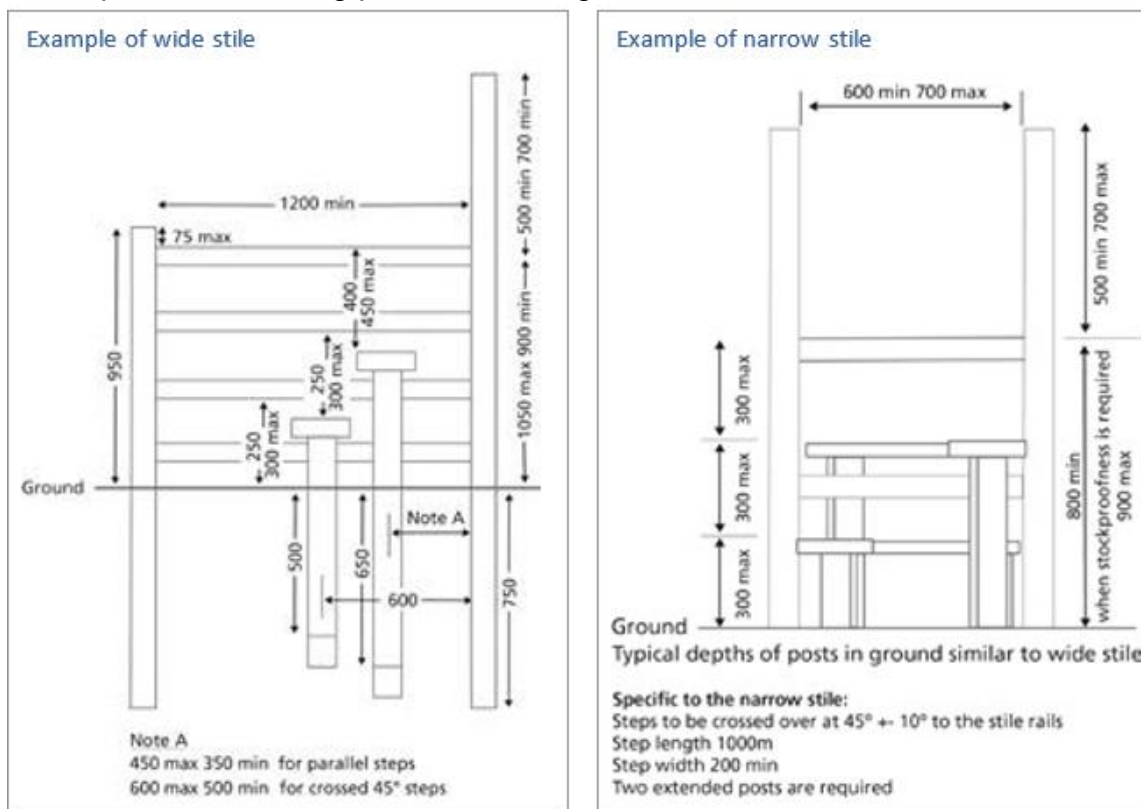

Badger Gate
Item Code: L005

Payment Rate: £41.10 each

This technical note describes the minimum standard of work required in order to receive payments for 'Badger Gates'. Any variation must be approved by the Welsh Government prior to starting the work.

Badgers normally follow the same route when moving around their territory. Fencing to manage an area of habitat should take into account established badger runs. Badger gates can be used to allow badgers to cross stock proof boundaries without damaging the fences.

You must adhere to the following:

- Install a badger gate using the same dimensions as shown in the diagram below.
- Gates must be located directly on existing badger runs in order to encourage the use of the gate by badgers.

- Bury the fence on either side of the gate to a sufficient depth into the ground to prevent badgers burrowing around the gate.
- Position a wooden or stone base under the gate to prevent erosion of the ground.

Requirements and guidance in addition to the specifications above:

- Best practice is to bury the fence to a depth of at least 15cm either side of the gate.
- Treat all timbers with a non-toxic, odourless preservative.

Example of a badger gate

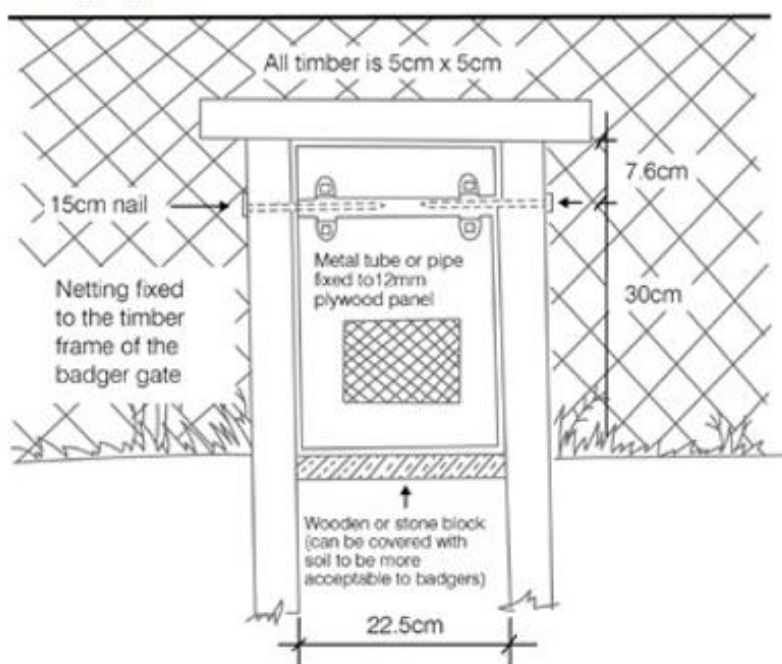

Piped Water Supply

Item Code: L006

Payment Rate: £1.39 /m

This technical note describes the minimum standard of work required in order to receive payments for 'Piped Water Supply'. Any variation must be approved by the Welsh Government prior to starting the work.

Piping can be used to supply drinking water to water troughs where stock have been prevented from accessing other water sources by Ffermio Bro activities.

You must adhere to the following:

- Install piping made from medium density blue polyethylene with a minimum external diameter of 2.5 cm.
- Use watertight joints made of brass or plastic.
- Bury pipework to a sufficient depth to prevent damage from surface activities.
- Reinststate disturbed ground to match the surrounding ground once pipework has been completed.

- Protect any pipework above ground from animal or frost damage.
- Ensure any pipes crossing open ditches or tracks are suitably protected. The pipe must be covered by a tubular steel guard or sleeve pipe, laid sufficiently below the ditch to allow space for ditch cleaning. When crossing farm tracks, ensure the pipe is sufficiently protected below the track.
- Control water supply at the point of supply and at each trough by isolating valves/stop cocks. The isolating valves/stop cocks must be protected against frost and damage from stock, and must be easily accessible.
- Where valve/stop cocks are buried, this must be at a minimum of 60cm and access should be available through a covered inspection chamber.
- Ensure that the water is able to supply sufficient cold potable water to continuously refill all the water troughs along its length throughout the year within 10 minutes.
- Ensure all water supply works are compliant with British Standards Codes of Practice BS 6572, as amended.

Do not:

- Damage other services such as water supply, waste, gas, electricity or telephone.

Requirements and guidance in addition to the specifications above:

- Consider combining access to valve positions with field drains to make inspection access easier.
- Consider a range of factors when determining pipe diameter. These include: water pressure, water capacity, variable flow, length of pipe, changes in altitude, volume of water required, number of troughs, number and type of stock using each trough.
- Where joints are buried underground, it is advisable to mark their locations, on fence posts for example, to assist with future maintenance.
- Bury pipework to a minimum depth of 60cm although this may need to be deeper if future deep ploughing or sub-soiling is envisaged.
- Lay pipes by trenching, mole plough or sub-soiler, depending on soil type and machinery available.
- Best practice when laying pipes under a ditch is that it is laid 60cm below the ditch to allow space for ditch cleaning.
- Best practice when laying pipes under farm tracks is to lay the pipe on a 7.5cm bed of sand and then covered by a further 10cm of sand before being overlaid by backfill.

Water Gate

Item Code: L007

Payment Rate: £337.81 each

This technical note describes the minimum standard of work required in order to receive payments for 'Water Gate'. Any variation must be approved by the Welsh Government prior to starting the work. Water gates are required to control stock where fence lines cross rivers and streams. They are especially useful where the water level varies considerably throughout the year.

You must adhere to the following:

- Construct a gate comprising a series of wooden droppers attached to a length of cable or a round wooden rail which is suspended horizontally between straining posts. Each gate has to be constructed to fit the profile of the individual stream.
- Ensure the water gate is separated from the main fence line by short lengths of wooden rail or netting, fixed to straining posts that have been suitably positioned.
- Attach droppers that are at least 5cm square in cross section. Droppers must be constructed from sawn untreated timbers. The droppers must be drilled and threaded onto the cable of fencing wire with 15cm lengths of plastic pipe acting as spacers. As a result, each dropper is 15cm apart.
- Increase the dimensions of the droppers to at least 7cm square, where the stream gully is over 1.5m deep. Hang droppers on a round wooden pole using loops of fencing wire.

Requirements and guidance in addition to the specifications above:

- Suitable crossing points will have a hard river bottom and reasonable access from both banks. The correct choice of crossing points will make both construction and maintenance easier.
- Hanging the gate separately from the main fence allows the gate to be pulled off during heavy floods without damaging the main fence. Minimum damage will be caused to the gate which can then be recovered, repaired and repositioned.
- It is advisable to create larger water gates in several sections which will reduce the risk of the whole gate being lost or damaged during severe floods.
- It is advisable to periodically clear the base of the water gate, as the accumulation of debris at the base of the water gate will put pressure on both wires and stakes and can result in damage.
- Hang water gates at an angle, with the bottom of the gate resting on the streambed on downstream side. This prevents stock passing underneath when the water level drops.

Examples of water gates

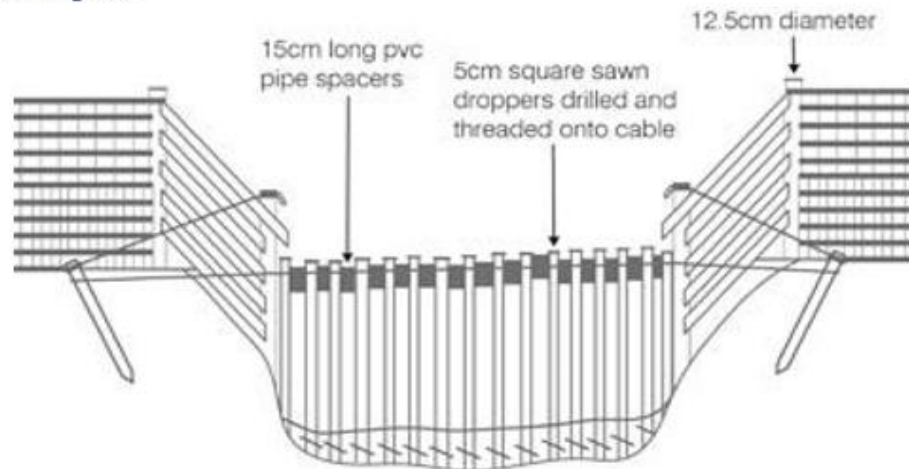

Examples of water gates

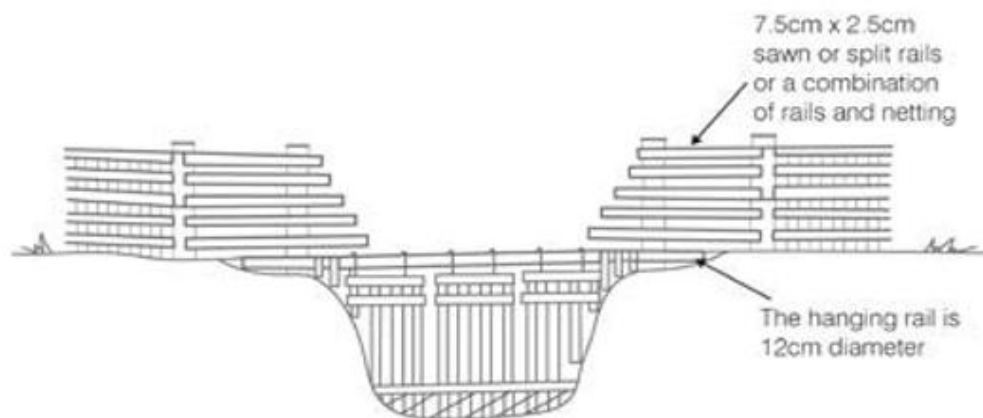

Water Troughs

Item Code: L008

Payment Rate: £224.00 each

This technical note describes the minimum standard of work required in order to receive payments for 'Water Troughs'. Any variation must be approved by the Welsh Government prior to starting the work.

Water troughs can be used to supply drinking water to livestock where they have been prevented from accessing other water sources by Ffermio Bro activities.

You must adhere to the following:

- Use water troughs made of galvanised steel, plastic or concrete.
- Install a trough at least 1.8m length. They must either be connected to a water supply or supplied from a bowser on a regular basis, in order to provide sufficient

potable water. The standard payment includes the cost of fittings such as ball cocks etc.

- Use water troughs that have been specifically designed for the purpose.
- Install the trough so that it does not spill or leak water – the payment rate includes an allowance for base supports.
- Ensure that water troughs conform to current British Standard Codes of Practice.

Do not:

- Locate water troughs in gateways or near footpaths.
- Locate water troughs in wet ground due to the risk of poaching.

Requirements and guidance in addition to the specifications above:

- Do not locate water troughs in known areas of botanical or wildlife interest.
- Aim to cause least landscape impact by locating the trough at the edge of fields and choose a material that has the minimum impact when viewed as part of the surrounding landscape.
- Install troughs of sufficient size to supply the type and number of stock in the field with their water requirements.

Post and Rail Fencing

Item Code: L009

Payment Rate: £12.54/m

This technical note describes the minimum standard of work required in order to receive payments for 'Post and Rail Fencing'.

Any variation must be approved by the Welsh Government prior to starting the work. Post and rail fencing is generally used where appropriate in the landscape, normally in parkland areas or for stock control along waterside features.

You must adhere to the following:

- Use fencing timber comprising either hardwood or pressure treated softwood.
- Use posts that are at least 1.8m in length, and no less than 12.5cm x 7.5cm cross section.
- Use posts that are square or rectangular.
- Install posts at centres not exceeding 2m (normally 1.8m as the standard length of rails is 3.6m).
- Set posts at a sufficient depth into the ground to ensure stability. The face of the post must be square to the fence line. If the tops of the posts are sawn after setting, the cut surfaces must be treated with a suitable preserving fluid of the same colour as the original timber treatment.
- Attach at least three rails of 3.8cm x 8.7cm sawn timber, skew nailed to the posts. Additional rails may be added where necessary.
- Attach rails on 'stock' side of the posts, to prevent stock pushing rails off posts.
- Alternate joints between rails on the posts, as shown on the diagram.
- Ensure there is at least 1m from the ground to the top of the uppermost rail.

Do not:

- Use trees and shrubs as strainers or fencing posts, or attach wire, staples or netting to them.
- Use concrete to secure posts as it promotes rotting of the posts at ground level.

Requirements and guidance in addition to the specifications above:

- Best practice is to set the posts at least 70cm into the ground to ensure stability, and secure the posts with rammed earth and stone.
- Ensure that you have the appropriate Flood Risk Activity Permit if you are planting or fencing near a main river, flood plain or flood defence structure. Alternatively, ensure you have the appropriate Ordinary Water Course Consent if you are carrying out works near an ordinary water course. What may be considered a ditch may be an ordinary watercourse, so consent may be required. As such, the permit/consent (or confirmation that a permit/consent is not needed) should be retained and made available on request. See General Rules for more details.
- Where Ffermio Bro activities include the installation of access furniture such as stiles or gates on a Public Right of Way, it is your responsibility to ensure you obtain approval under Section 147 of the Highways Act, 1980, from the appropriate Highway Authority.

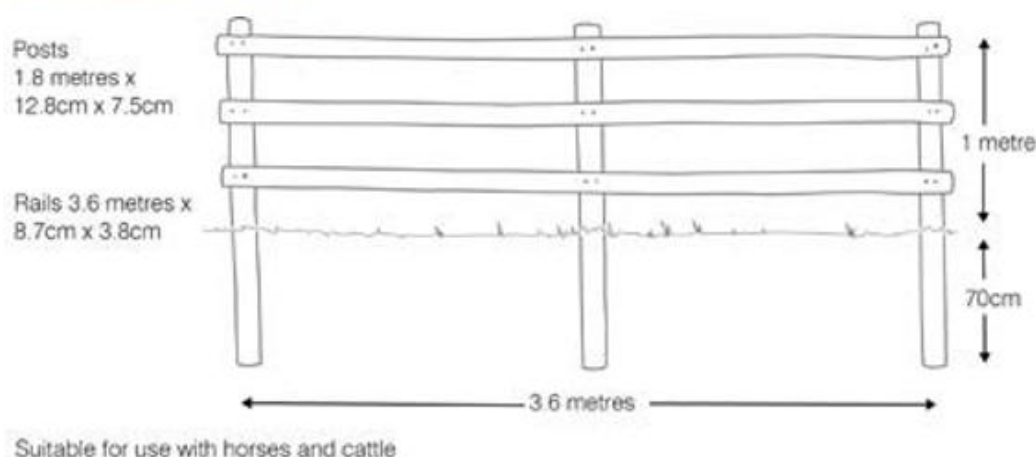
Example of a Post and Rail Fence

Post and Wire Fencing

Item Code: L010

Payment Rate: £5.81/m

This technical note describes the minimum standard of work required in order to receive payments for 'Post and Wire Fencing'. Any variation must be approved by the Welsh Government prior to starting the work.

You must adhere to the following:

- Ensure that you have obtained, and adhere to any licences, consents or permissions that are needed.

- Use fencing timber comprising either hardwood or pressure treated softwood.
- Ensure that timbers, wire, netting and galvanised staples consist of new materials.
- Attach at least three lines of wire made up of either galvanised mild steel wire (4mm gauge) or two ply twisted barbed wire (2.5mm gauge). The top wires of any fencing erected next to public access routes must consist of plain wire or an additional line of plain wire must be affixed to the outside of the posts closest to the route in question.
- Use straining posts that are a minimum of 12.5cm cross section and at least 2m long. Straining posts must be set into the ground at a sufficient depth to ensure stability. Straining posts must be placed at either end of the fence line and at centres of 100m or less, as well as at every horizontal or vertical change of direction.
- Attach struts at each end of the fence line and at all changes of slope and direction. Struts must have a top diameter of at least 6.5cm and must be supported to prevent them splaying outwards.
- Use intermediate posts that are at least 6.5cm diameter (round posts and sawn timber) and at least 1.7m long. Half round posts are acceptable provided they measure at least 6.5cm from the midpoint of the sawn side to the mid-point of the round side. Intermediate posts must be set at centres of 3m or less.
- Attach wire to posts with galvanised staples.
- Attach the top wire no less than 1.05m from the ground.
- Ensure that the new fencing conforms to British Standards 1722 and 4102, as amended.

Do not:

- Use trees and shrubs as strainers or fencing posts, or attach wire, staples or netting to them.

Requirements and guidance in addition to the specifications above:

- Best practice is to set the posts at least 1m into the ground to ensure stability.
- Diagonal struts must be supported with either a base plate or a suitably positioned intermediate post to prevent them splaying outwards.
- Ensure you have the appropriate Flood Risk Activity Permit if you are planting or fencing near a main river, flood plain or flood defence structure. Alternatively, ensure you have the appropriate Ordinary Water Course Consent if carrying out works near an ordinary water course. What may be considered a ditch may be an ordinary watercourse, so consent may be required. As such, the permit/consent (or confirmation that a permit/consent is not needed) should be retained and made available on request. See General Rules for more details.
- Where Ffermio Bro activities include the installation of access furniture such as stiles or gates on a Public Right of Way, it is your responsibility to ensure you obtain approval under Section 147 of the Highways Act, 1980, from the appropriate Highway Authority.

Example Diagram of Three Line Wire Fence

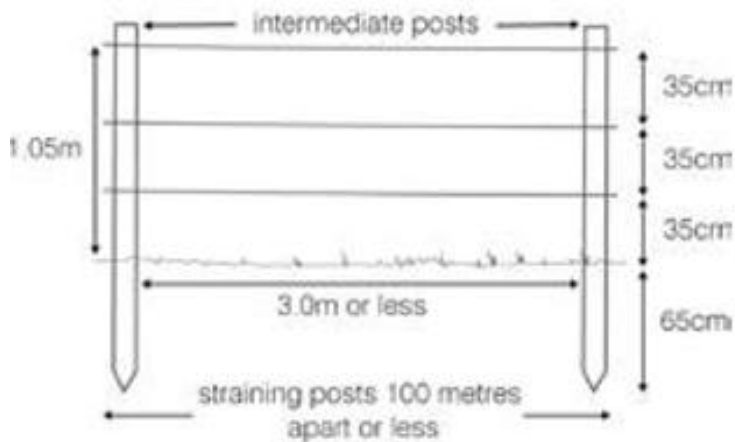

Timber Field Gates (Hardwood) Item Code: L011

Payment Rate: £466.22 each

This technical note describes the minimum standard of work required in order to receive payments for 'Timber Field Gates (Hardwood)'. Any variation must be approved by the Welsh Government prior to starting the work.

You must adhere to the following:

- Install timber field gates that are at least 2.4m wide, but no more than 4.2m wide. Any openings greater than 4.2m must have two leaves.
- Use timber field gates constructed from hardwood only, which complies with the dimensions set out in the diagram below.
- Use timber field gates that conform to the specifications set out in the diagram below as well as those of British Standard 3470, as amended.
- Hang gates on timber gate posts at least 2.1m long. Hanging posts must be at least 200mm x 200mm in cross section. Shutting posts must be at least 175mm x 175mm in cross section.
- Set gateposts correctly into the ground, using concrete if necessary and fit with appropriate hangings and latches.

Do not:

- Use hanging or shutting posts as straining posts for fencing. A short length of split timber should be used to form a horizontal strut between the gate post and adjacent straining post.
- Use second hand material for constructing gates unless approved in advance by the Welsh Government.

Example of Timber Field Gate (Hardwood)

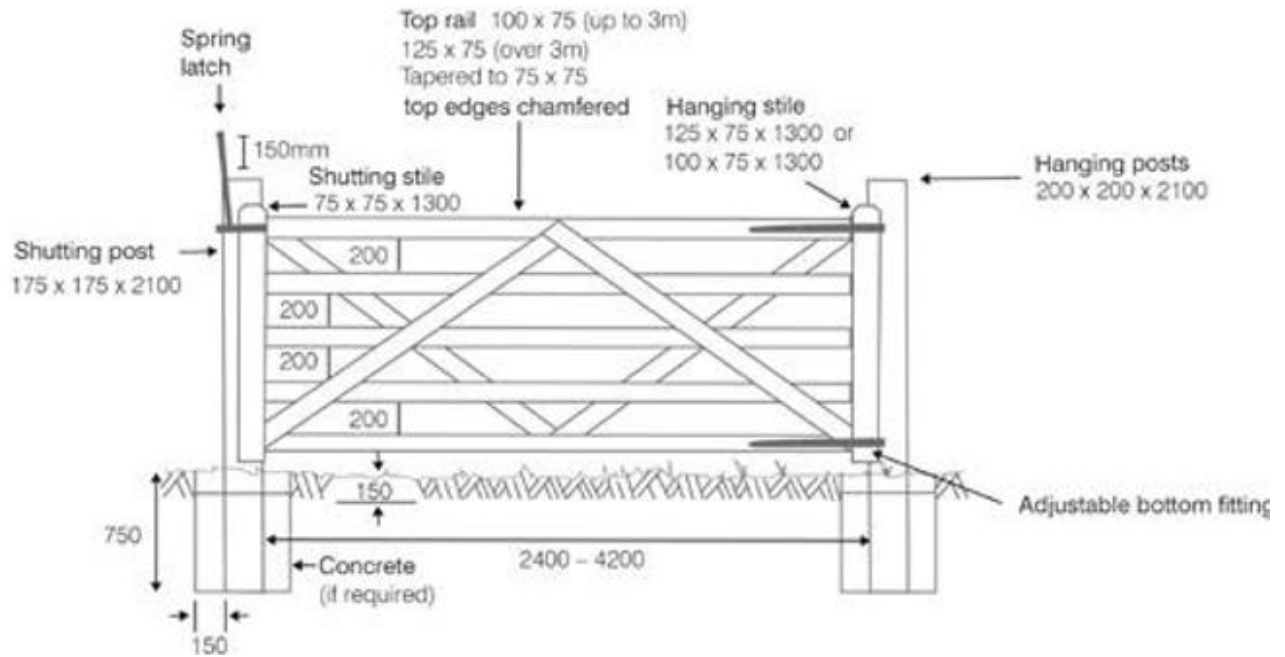

Timber Field Gates (Softwood)

Item Code: L012

Payment Rate: £225.92 each

This technical note describes the minimum standard of work required in order to receive payments for 'Timber Field Gates (Softwood)'. Any variation must be approved by the Welsh Government prior to starting the work.

You must adhere to the following:

- Install timber field gates that are at least 2.4m wide, but no more than 4.2m wide. Any openings greater than 4.2m must have two leaves.
- Use timber field gates constructed from hardwood or pressure treated softwood, which complies with the dimensions set out in the diagram below.
- Use timber field gates that conform to the specifications set out in the diagram below as well as those of British Standard 3470, as amended posts must be at least 175mm x 175mm in cross section.
- Set gateposts correctly into the ground, using concrete if necessary and fit with appropriate hangings and latches.

Do not:

- Use hanging posts or shutting posts as straining posts for fencing. A short length of split timber should be used to form a horizontal strut between the gate post and adjacent straining post.
- Use second hand material for constructing gates unless approved in advance by the Welsh Government.

Example of Timber Field Gate (Softwood)

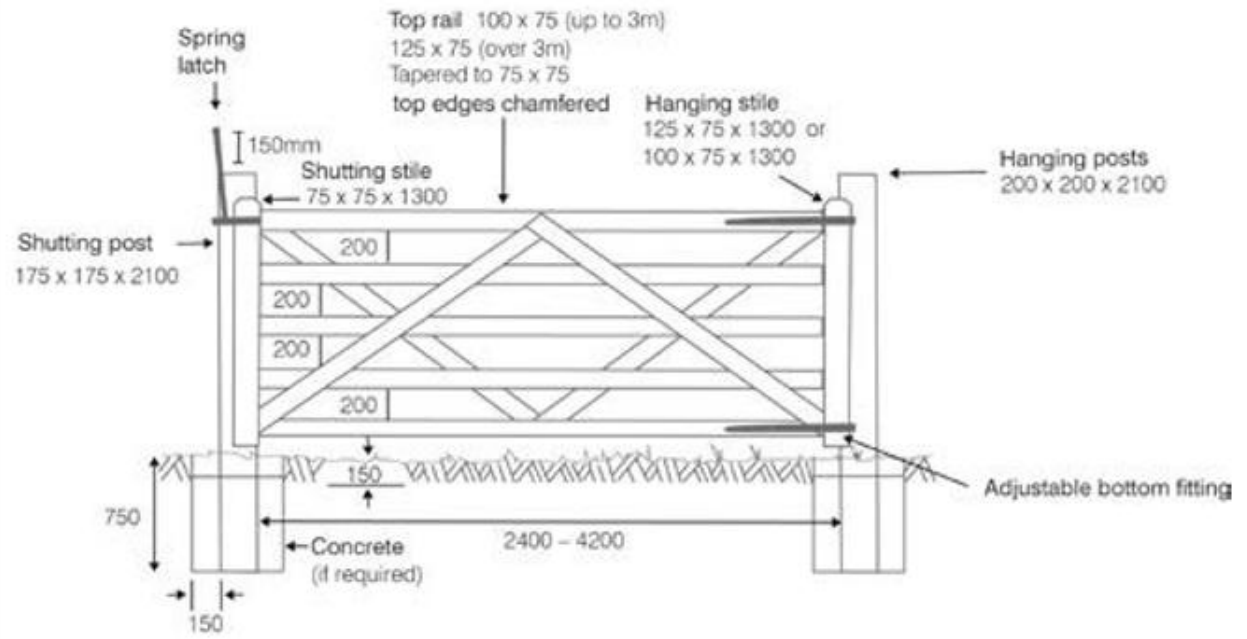

Parkland Tree Stock Guards

Item Code: L013

Payment Rate: £94.40 each

This technical note describes the minimum standard of work required in order to receive payments for 'Parkland Tree Stock Guards'. Any variation must be approved by the Welsh Government.

You must adhere to the following:

- Install tree guards that are large enough and designed correctly to protect from any livestock that will have access to the land.
- All guards constructed from timber rails must be at least 1.2m high and set at least 1m from the tree to protect against sheep (or 1.5m to protect against cattle and horses). Each of the 4 corner posts should have a minimum diameter of 10cm x 10cm. At least 4 wooden rails with a minimum diameter of 10cm x 5cm should be fixed to the outside of the posts. Galvanised netting should then be fixed around the outside of the structure and held in place with galvanised staples. Triangular shaped enclosures are only acceptable in parklands where sheep are the sole livestock.
- Use fencing timber comprising either hardwood or pressure treated softwood.
- Ensure that timbers, wire, netting and galvanised staples consist of new materials.
- If traditional metal guards are used rather than wooden guards, ensure they are sufficiently sized to protect from all livestock.

Requirements and guidance in addition to the specifications above:

- The choice of tree guard will depend upon:
 - The size of tree to be protected.
 - The type of damage expected, e.g. browsing, bark stripping, fraying.

- Type of animal most likely to cause damage.
- Period of time the tree is at risk from damage.
- The visual appearance of the guard (UKWAS General Forest Practice 24 Consider the impact of fencing on landscape).
- Use a combination of vertical posts and horizontal rails to build a rigid structure. Fix wire netting around it to prevent access by livestock. The horizontal rails will prevent the posts from being loosened. A variety of stock might have access to the parkland over time so the guard must be strong enough to withstand the worst case scenario. Do not try to increase distance of the top rail from tree by slanting the posts outwards. This will make it difficult to fix the netting securely in place.
- It is not necessary to top the enclosure with barbed wire as this is unlikely to stop animals leaning over, and you will make it more difficult to get into the enclosure to tend the tree. Barbed wire may also cause injury to both you and your livestock.
- Additional sets of rails may also be placed mid-way up the posts to provide additional strength.
- Triangular shaped enclosures are only acceptable in parklands where sheep are the sole livestock. Such enclosures must be at least 1.2m high and set at least 1m from the tree to protect against sheep. It is important to remember that as the tree grows it may be necessary to widen the guard.
- Traditional metal types of guards are used in long established parklands. It is important that they are checked regularly to ensure that the tree does not grow into the metal work and become deformed.
- Such guards were originally made out of wrought iron but are now available in mild steel.

Examples of Parkland Tree Guards

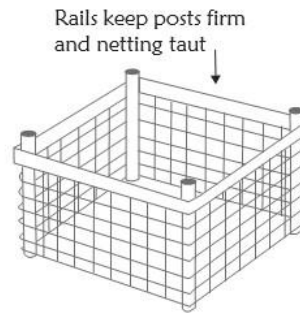
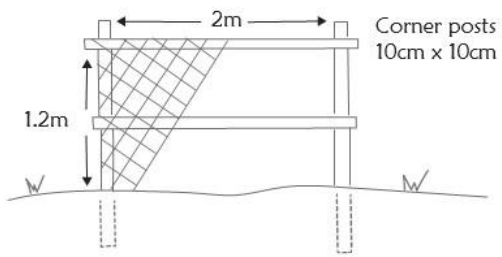

a) Suitable for use with

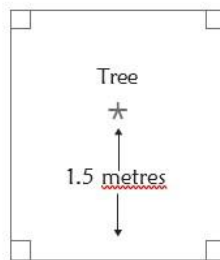
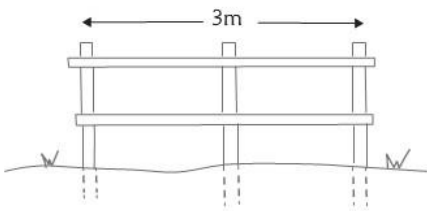

b) Suitable for use with horses and

3. Traditional Metal Types

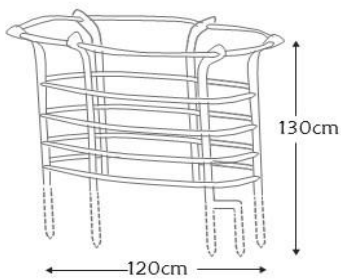

2. Traditional Tree Guard

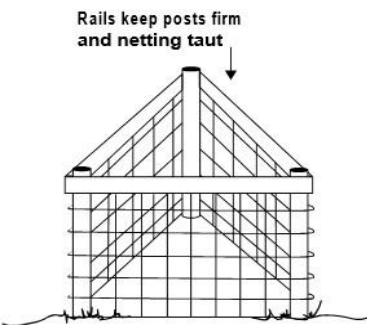
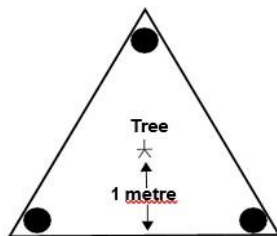

Tree Shelter (60cm With Stake)

Item Code: L014

Payment Rate: £2.21 each

This technical note describes the minimum standard of work required in order to receive payments for 'Tree Shelter (60cm with stake)'. Any variation must be approved by the Welsh Government prior to starting the work.

Newly planted trees and shrubs only need protection where animals or machinery might damage them. Fencing will usually provide more economic protection for groups of trees and shrubs against machinery or large browsing animals, in combination with spiral rabbit guards to protect against rabbits and hares.

Individual tree shelters and stakes can also be used where lengths of fencing would be unsightly, for example in parklands.

You must adhere to the following:

- Insert a stake vertically into the ground next to each newly planted tree. The stake should have a diameter of 2.5cm x 2.5cm on sheltered sites and 3cm x 3cm on more exposed sites.
- Fix all tree shelters to the stake with wire or plastic cable clips.
- Ensure that the stake is no taller than the shelter.

Do not:

- Allow weeds to grow inside the shelters.

Requirements and guidance in addition to the specifications above:

- Tree shelters to protect young trees are translucent plastic tubes up to 2m in height, with a diameter of up to 12cm. They are constructed of twin wall polypropylene.
- Each shelter should provide support and protection for some 5 -10 years before it bio-degrades.
- Although shelters come in a range of colours, there is little difference between them in terms of tree growth. When planting under established trees, where light intensity is likely to be low, it is generally better to use clear translucent tubes.
- Tree shelters need to be above the browse height of the animal. This can vary from 60cm for rabbits and hares, to 2m for Roe deer. Sheep can browse at 1.2m-1.5m high.
- The removal of weeds around trees and in shelters is crucial as the weeds can compete for nutrients and light. Trees in tree shelters must be weeded for the first 2-3 years of life. Weeds growing inside the tree shelter must also be removed. This can be done by lifting the shelter slightly and carefully pulling the weeds out from the tube by hand.
- Any plants that have been loosened or partly lifted by winds and winter frosts should be trodden back in carefully. Regularly inspect fencing, tree guards,

stakes and tree ties (loosen tight ties as these will constrict tree growth) and prevent trees growing through or chafing against tree guards.

Trees - Standards

Item Code: L015

Payment Rate: £24.35 each

This technical note describes the minimum standard of work required in order to receive payments for 'Trees Standards (no fencing)'. Any variation must be approved by the Welsh Government.

Growing trees remove carbon dioxide from the atmosphere (which has a positive impact on climate change) and absorb a lot of water, reducing the amount of water running off farmland. Standard trees in hedgerows are also standout features in the landscape and provide many benefits for our native biodiversity.

You must adhere to the following:

- Plant sturdy plants, which are at least 1.8m in height.
- Plant only native species as shown on the table below.
- Trees and shrubs need to be UK grown and ideally from Plant Healthy stock for biosecurity reasons.

Do not:

- Plant ash trees as part of any planting mix due to ash dieback disease (*Hymenoscyphus fraxinea*).
- Allow damage from machinery or browsing animals (including wild animals).

Requirements and guidance in addition to the specifications above:

- Standard trees in new hedgerows should be established individually, ideally at approximately 50m – 100m spacings.
- You must protect the standard trees from browsing using a tree shelter (see L014 Tree Shelter (60cm With Stake)) and the tree planting must be carried out within the newly created hedgerow.
- Ensure you have the appropriate Flood Risk Activity Permit if you are planting or fencing near a main river, flood plain or flood defence structure. Also, ensure you have the appropriate Ordinary Water Course Consent if you are carrying out works near an ordinary water course. What may be considered a ditch may be an ordinary watercourse, so consent may be required. As such, the permit/consent, or confirmation that a permit/consent is not needed, should be retained, and made available on request. See General Rules for more details.
- If undertaking any spraying as part of this activity ensure you have obtained any consents that may be necessary.
- Where Ffermio Bro activities include the installation of access furniture such as stiles or gates on a Public Right of Way, it is your responsibility to ensure

you obtain approval under Section 147 of the Highways Act, 1980, from the appropriate Highway Authority. This will ensure that when the trees are grown, they will not shade the surface of the pond.

- Consideration should also be given when establishing scrub and tree cover to avoid any impact on water supply for ponds or the likelihood of damaging any pond lining.
- The planting season normally runs from 1 October to 30 April. In practice, frost and snow usually divides this period into two planting spells: October to December; and during March. At higher altitudes, planting can be extended into early April.
- Autumn planting is preferred for broadleaved trees and shrubs, as roots will grow in warm spells and lessen the effect of any subsequent spring drought. In exposed sites or areas where winter storms are likely, spring planting may be preferable.
- Order as far in advance as possible to ensure the correct trees are available. Request that plants are delivered as close as possible to the planting date. It is best to choose an established local nursery, because they will usually have a reputation to maintain the trees and your transport costs should be lower. In addition, the plants will be out of the ground for the minimum length of time.
- Wherever possible, try to obtain plants grown from locally obtained seeds or cuttings (native provenance), since these will do better under local conditions and are more valuable for wildlife than imported stock.
- Try to be on hand when plants arrive so you can ensure they are in good physical condition. Keep the roots covered at all times before planting to prevent damage and drying out. Whilst cold is unlikely to be harmful, hot sun and any form of drying, such as wind, can very quickly cause damage or kill the plants.
- If immediate planting is not possible, dig a trench before delivery and store plants in this with the roots covered so they are kept moist and cool. Protect the plants from animals, including small mammals.
- There are four main methods of planting using a spade, which are illustrated at the end of the tree planting notes. More specialised tools are available for use on large scale plantings.
- Annual maintenance is essential to ensure both survival and healthy growth. Plants should be watered both regularly and liberally during prolonged dry spells. It is advisable to apply water slowly, so it has time to soak into the ground adjacent to the tree. A mulch may serve to reduce the frequency with which watering is needed.
- Plants should be kept clear of competing weeds and grasses (weeding will also reduce mouse and vole damage). Control can be achieved with a thick mulch of bark chippings or by using a 500-gauge black polythene sheet and pegging down securely. Alternatively, carefully cut back grass and other vegetation in the area above the tree roots.
- Weeding is advisable twice in the first year after planting and once a year thereafter, until the tree is clear of surrounding vegetation. Cut weeds by hand or use herbicides to control grasses, docks, thistles, and ragwort. If using a

strimmer, take care to protect the tree stem from damage. Any chemicals used must have a label recommendation for use on the target species and for the intended method of application. All manufacturers label recommendations regarding method of application must be strictly adhered to.

- Any plants that have been loosened or partly lifted by winds and winter frosts should be trodden back in carefully. Regularly inspect fencing, tree guards, stakes, and tree ties (loosen tight ties as these will constrict tree growth) and prevent trees growing through or chafing against tree guards.

For an extensive list of trees native to Wales, see Forest Research's *Using Local Stock for Planting Native Trees and Shrubs* (zones 303 and 304 apply).

Suggested Native Trees and Shrubs Suitable for Planting			
Alder	Cherry (Wild & Bird)	Guelder Rose	Rowan (Mountain Ash)
Aspen	Crab Apple	Hawthorn	Scots Pine
Beech	Dog Rose	Hazel	Spindle
Birch (Silver & Downy)	Elder	Holly	Willow (Crack, Goat & Grey)
Blackthorn	Field Maple	Lime (Small & large leaved)	White Poplar
Black Poplar		Oak (Sessile & Pedunculate)	Yew

Example of the four main methods of planting using a spade

1. Pit Planting

Use for large plants or those with bulky root systems

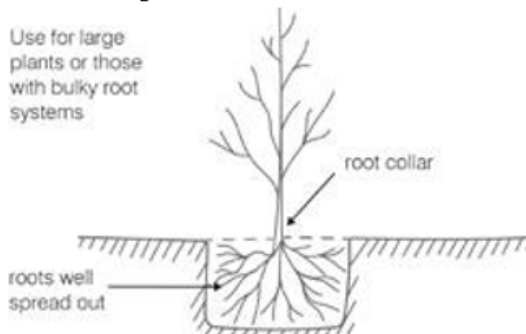

2. Turf Planting

Use on wet sites with poor soil

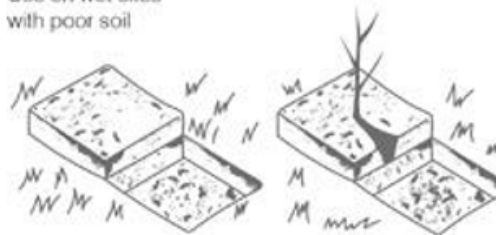

3. Notch or Slit Planting

Use for smaller plants with compact root systems

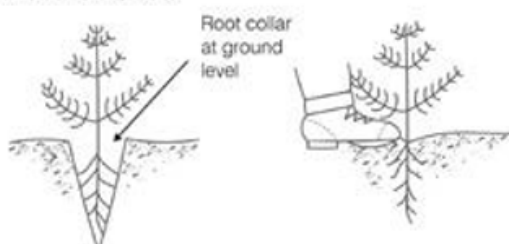

4. Ridge or Mount Planting

Use on wet sites where turf is difficult to cut

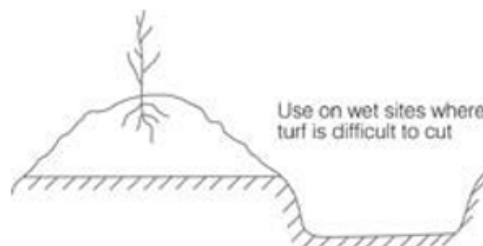

Trees and Shrubs (Transplants)

Item Code: L016

Payment Rate: £2.03 each

This technical note describes the minimum standard of work required in order to receive payments for 'Trees and Shrubs (Transplants)'. Any variation must be approved by the Welsh Government prior to starting the work.

Planting small areas of woodland can provide benefits for wildlife and landscape. Growing trees removes carbon dioxide from the atmosphere (which has a positive impact on climate change) and absorbs a lot of water, reducing the amount of water running off farmland into rivers.

You must adhere to the following:

- Plant sturdy plants, which are at least 50cm in height.
- Plant only native species, as shown on the table below.
- Trees and shrubs need to be UK grown and ideally from Plant Healthy stock for biosecurity reasons

Do not:

- Plant ash trees as part of any planting mix due to ash dieback disease (*Hymenoscyphus fraxineus*).
- Allow damage from machinery or browsing animals (including wild animals).

Requirements and guidance in addition to the specifications above:

- You can establish trees individually or in groups of trees.
- If you are planting trees in groups, they must be established at a planting density equivalent to 400 to 2500 trees per hectare. The width of the area used to plant a group of trees can be up to a maximum width of 10m wide in any field parcel. The 10m maximum width limit will be taken from the mapped fence line to the mapped field boundary, which may already include an existing field boundary, such as a hedge, so you may have to include this when establishing the 10m width. You must protect the trees from browsing using spiral rabbit guards or tubes and the area of tree planting must also be fenced to exclude livestock.
- Ensure you have the appropriate Flood Risk Activity Permit if you are planting or fencing near a main river, flood plain or flood defence structure. Also, ensure you have the appropriate Ordinary Watercourse Consent if you are carrying out works near an ordinary watercourse. What may be considered a ditch may be an ordinary watercourse, so consent may be required. As such, the permit/consent, or confirmation that a permit/consent is not needed, should be retained and made available on request. See General Rules for more details.
- If undertaking any spraying as part of this activity, ensure you have obtained any consents that may be necessary.

- Where Ffermio Bro activities include the installation of access furniture, such as stiles or gates on a Public Right of Way, it is your responsibility to ensure you obtain approval under Section 147 of the Highways Act, 1980, from the appropriate Highway Authority.
- Transplants are 1-2 year old plants with a large proportion of root in relation to shoot, which gives them good powers of survival, especially in poor soils and on exposed sites. They will generally outgrow whips in a few years to produce healthier, better-formed trees.
- A high degree of protection from machinery and animals is needed.
- Careful maintenance during first few years is essential. They are considerably cheaper than whips and standards and are usually purchased in bulk.
- Where possible, trees or shrubs should not be planted within 15 metres of ponds. This will ensure, when the trees are grown, they will not shade the surface of the pond. Consideration should also be given when establishing scrub and tree cover to avoid any impact on water supply for ponds or the likelihood of damaging any pond lining.
- The planting season normally runs from 1 October to 30 April. In practice, frost and snow usually divides this period into two planting spells: October to December and during March. At higher altitudes, planting can be extended into early April.
- Autumn planting is preferred for broadleaved trees and shrubs, as roots will grow in warm spells and lessen the effect of any subsequent spring drought. In exposed sites or areas, where winter gales are likely, spring planting may be preferable.
- Order as far in advance as possible to ensure the correct trees are available. You should request plants are delivered as close as possible to the planting date. It is best to choose an established local nursery because your transport costs should be lower. In addition, the plants will be out of the ground for the minimum length of time.
- Wherever possible, try to obtain plants grown from locally obtained seeds or cuttings (native provenance), since these will do better under local conditions and are more valuable for wildlife than imported stock.
- Try to be on hand when plants arrive so you can ensure they are in good physical condition. Keep the roots covered at all times before planting to prevent damage and drying out. Whilst cold is unlikely to be harmful, hot sun and any form of drying such as wind, can very quickly cause damage or kill the plants.
- If immediate planting is not possible, dig a trench before delivery and store plants in this with the roots covered so they are kept moist and cool. Protect the plants from animals, especially small mammals.
- There are four main methods of planting using a spade, which are illustrated in this note. More specialised tools are available for use on large-scale plantings.
- Use individual tree guards and stakes where lengths of fencing would be uneconomic or unsightly, such as single or widely spaced trees in parklands, or where damage from machinery is possible.

- Annual maintenance is essential to ensure both survival and healthy growth. Plants should be watered, both regularly and liberally, during prolonged dry spells. It is advisable to apply water slowly so it has time to soak into the ground adjacent to the tree. A mulch may serve to reduce the frequency with which watering is needed.
- Plants should be kept clear of competing weeds and grasses (weeding will also reduce mouse and vole damage). Control can be achieved with a thick mulch of bark chippings or by using a 500-gauge black polythene sheet and pegging down securely. Alternatively, carefully cut back grass and other vegetation in the area above the tree roots.
- Weeding is advisable twice in the first year after planting and once a year thereafter, until the tree is clear of surrounding vegetation. Cut weeds by hand or use herbicides to control grasses, docks, thistles and ragwort. If using a strimmer, take care to protect the tree stem from damage. Any chemicals used must have a label recommendation for use on the target species and for the intended method of application. All manufacturers label recommendations regarding method of application must be strictly adhered to.
- Any plants that have been loosened or partly lifted by winds and winter frosts should be trodden back in carefully. Regularly inspect fencing, tree guards, stakes and tree ties (loosen tight ties as these will constrict tree growth) and prevent trees growing through or chafing against tree guards.

Suggested Native Trees and Shrubs Suitable for Planting			
Alder	Cherry (Wild & Bird)	Guelder Rose	Rowan (Mountain Ash)
Aspen	Crab Apple	Hawthorn	Scots Pine
Beech	Dog Rose	Hazel	Spindle
Birch (Silver & Downy)	Elder	Holly	Willow (Crack, Goat & Grey)
Blackthorn	Field Maple	Lime (Small & large leaved)	White Poplar
Black Poplar		Oak (Sessile & Pedunculate)	Yew

For an extensive list of trees native to Wales, see Forest Research's [*Using Local Stock for Planting Native Trees and Shrubs*](#) (zones 303 and 304 apply).

Example of the four main methods of planting using a spade

1. Pit Planting

Use for large plants or those with bulky root systems

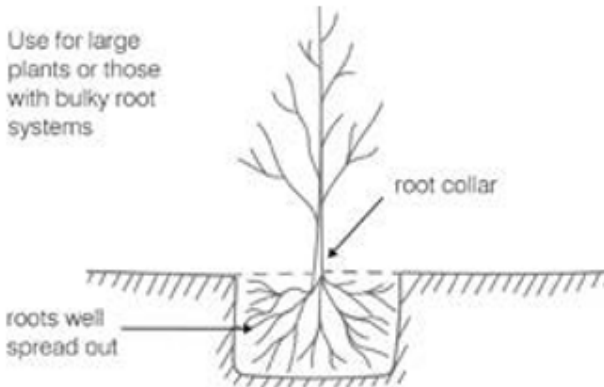

2. Turf Planting

Use on wet sites with poor soil

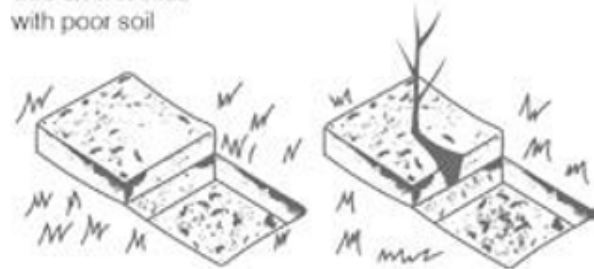

3. Notch or Slit Planting

Use for smaller plants with compact root systems

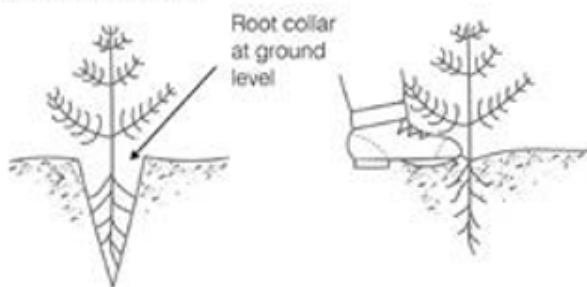

4. Ridge or Mount Planting

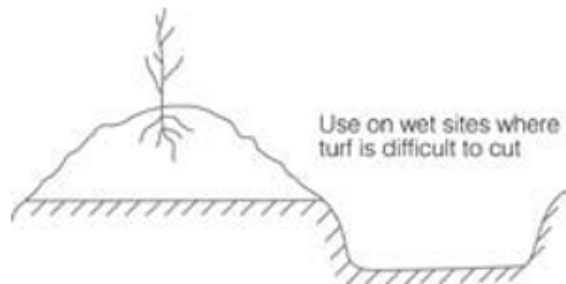

Trees and Shrubs - Whips

Item Code: L017

Payment Rate: £6.32 each

This technical note describes the minimum standard of work required in order to receive payments for 'Trees and Shrubs – whips'. Any variation must be approved by the Welsh Government.

Planting small areas of woodland can provide benefits for wildlife and landscape. Growing trees removes carbon dioxide from the atmosphere (which has a positive impact on climate change) and absorbs a lot of water, reducing the amount of water running off farmland.

You must adhere to the following:

- Plant sturdy plants, which are at least 1m in height.

- Plant only native species as shown on the table below.
- Trees and shrubs need to be UK grown and ideally from Plant Healthy stock for biosecurity reasons

Do not:

- Plant ash trees as part of any planting mix due to ash dieback disease (*Chalara fraxinea*).
- Allow damage from machinery or browsing animals (including wild animals).

Requirements and guidance in addition to the specifications above:

- You can establish trees individually or in groups of trees.
- If you are planting trees in groups, they must be established at a planting density equivalent to 400 to 2500 trees per hectare. The width of the area used to plant a group of trees can be up to a maximum width of 10m wide in any field parcel. The 10m maximum width limit will be taken from the mapped fence line to the mapped field boundary, which may already include an existing field boundary, such as a hedge, so you may have to include this when establishing the 10m width. You must protect the trees from browsing using spiral rabbit guards or tubes and the area of tree planting must also be fenced to exclude livestock.
- Ensure that you have the appropriate Flood Risk Activity Permit if you are planting or fencing near a main river, flood plain or flood defence structure. Alternatively, ensure you have the appropriate Ordinary Water Course Consent if you are carrying out works near an ordinary water course. What may be considered a ditch may be an ordinary watercourse, so consent may be required. As such, the permit/consent, or confirmation that a permit/consent is not needed, should be retained and made available on request. See General Rules for more details.
- If undertaking any spraying as part of this activity ensure you have obtained any consents that may be necessary.
- Where Ffermio Bro activities include the installation of access furniture such as stiles or gates on a Public Right of Way, it is your responsibility to ensure you obtain approval under Section 147 of the Highways Act, 1980, from the appropriate Highway Authority.
- Whips are used for individual tree planting and for hedgerow trees – trees of 1m or taller with little branching. These should be used occasionally, in specific circumstances.
- Although more expensive and less sturdy than transplants, they are cheaper and easier to establish than standards.
- Usually short enough not to require stakes and ties, they are tall enough to prevent the leading shoots being damaged by hares and are easier to protect from rabbits than transplants. Weeding is less critical but they will need protection from browsing animals and machinery.
- Where possible, trees or shrubs should not be planted within 15 metres of ponds. This will ensure that when the trees are grown they will not shade the surface of the pond. Consideration should also be given when establishing

scrub and tree cover to avoid any impact on water supply for ponds or the likelihood of damaging any pond lining.

- The planting season normally runs from 1 October to 30 April. In practice, frost and snow usually divides this period into two planting spells: October to December; and during March. At higher altitudes, planting can be extended into early April.
- Autumn planting is preferred for broadleaved trees and shrubs, since roots will grow in warm spells and lessen the effect of any subsequent spring drought. In exposed sites or areas where winter gales are likely, spring planting may be preferable.
- Order as far in advance as possible to ensure the correct trees are available. Request that plants are delivered as close as possible to the planting date. It is best to
- choose an established local nursery because they will usually have a reputation to maintain and your transport costs should be lower. In addition, the plants will be out of the ground for the minimum length of time.
- Wherever possible try to obtain plants grown from locally obtained seeds or cuttings (native provenance), since these will do better under local conditions and are more valuable for wildlife than imported stock.
- Try to be on hand when plants arrive so you can ensure they are in good physical condition. Keep the roots covered at all times before planting to prevent damage and drying out. Whilst cold is unlikely to be harmful, hot sun and any form of drying such as wind, can very quickly cause damage or kill the plants.
- If immediate planting is not possible, dig a trench before delivery and store plants in this with the roots covered so they are kept moist and cool. Protect the plants from animals, including small mammals.
- There are four main methods of planting using a spade, which are illustrated at the end of this note. More specialised tools are available for use on large scale plantings.
- Use individual tree guards and stakes where lengths of fencing would be uneconomic or unsightly, such as single or widely spaced trees in parklands, or where damage from machinery is possible.
- Annual maintenance is essential to ensure both survival and healthy growth. Plants should be watered both regularly and liberally during prolonged dry spells. It is advisable to apply water slowly so it has time to soak into the ground adjacent to the tree. A mulch may serve to reduce the frequency with which watering is needed.
- Plants should be kept clear of competing weeds and grasses (weeding will also reduce mouse and vole damage). Control can be achieved with a thick mulch of bark chippings or by using a 500-gauge black polythene sheet and pegging down securely. Alternatively, carefully cut back grass and other vegetation in the area above the tree roots.
- Weeding is advisable twice in the first year after planting and once a year thereafter, until the tree is clear of surrounding vegetation. Cut weeds by hand or use herbicides to control grasses, docks, thistles and ragwort.

- If using a strimmer take care to protect the tree stem from damage. Any chemicals used must have a label recommendation for use on the target species and for the intended method of application. All manufacturers label recommendations regarding method of application must be strictly adhered to.
- Any plants that have been loosened or partly lifted by winds and winter frosts should be trodden back in carefully. Regularly inspect fencing, tree guards, stakes and tree ties (loosen tight ties as these will constrict tree growth) and prevent trees growing through or chafing against tree guards.

Suggested Native Trees and Shrubs Suitable for Planting			
Alder	Cherry (Wild & Bird)	Guelder Rose	Rowan (Mountain Ash)
Aspen	Crab Apple	Hawthorn	Scots Pine
Beech	Dog Rose	Hazel	Spindle
Birch (Silver & Downy)	Elder	Holly	Willow (Crack, Goat & Grey)
Blackthorn	Field Maple	Lime (Small & large leaved)	White Poplar
Black Poplar		Oak (Sessile & Pedunculate)	Yew

For an extensive list of trees native to Wales, see Forest Research's [Using Local Stock for Planting Native Trees and Shrubs](#) (zones 303 and 304 apply).

Example of the four main methods of planting

1. Pit Planting

Use for large plants or those with bulky systems

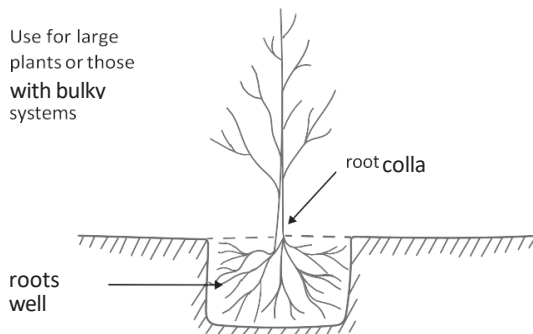

2. Turf Planting

Use on wet sites

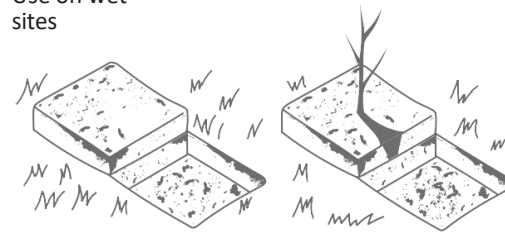

3. Notch or Slit Planting

Use for smaller plants with compact root systems

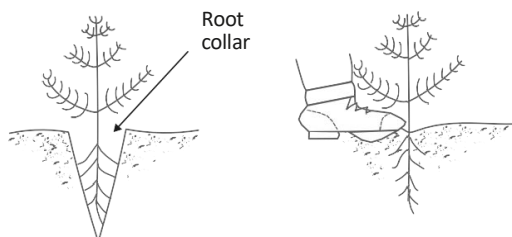

4. Ridge or Mount Planting

Use on wet sites where turf is difficult to cut

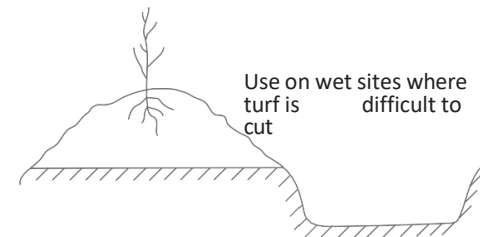

Sabre Planting

Item Code: L018

Payment Rate: £6.94 each

This technical note describes the standard of work required in order to receive payments for 'Sabre Planting'. Any variation must be approved by the Welsh Government.

Pioneered by an independent local charity 'Bugeiliaid y Coed' (Tree Shepherds), the 'No Fence Planting' technique mimics the way in which self-sown trees establish themselves naturally on grazed farmland.

Trees over 1m in height can be 'sabre-planted' perpendicular to steep ground (rather than pointing straight up) so that the leading shoots cannot be reached by browsing sheep and cattle. Such trees typically have a 'sabre-shaped' profile and can be seen growing in most valleys in Wales.

You must adhere to the following:

- Plant sturdy plants, which are at least 1m in height
- Plant at an angle perpendicular to the slope on steep ground
- Plant only native species as shown on the table below.
- Trees and shrubs need to be UK grown and ideally from Plant Healthy stock for biosecurity reasons

Do not:

- Plant ash trees as part of any planting mix due to ash dieback disease (*Chalara fraxinea*).

Requirements and guidance in addition to the specifications above:

- Trees can be planted amongst gorse.
- Steep and broken ground with bracken is ideal for 'Sabre Planting'.
- Other no-fence methods include the planting of 1.5m-2m trees.
- Where possible, trees or shrubs should not be planted within 15 metres of ponds. This will ensure that when the trees are grown they will not shade the surface of the pond. Consideration should also be given when establishing scrub and tree cover to avoid any impact on water supply for ponds or the likelihood of damaging any pond lining.
- The planting season normally runs from 1 October to 30 April. In practice, frost and snow usually divides this period into two planting spells: October to December; and during March. At higher altitudes, planting can be extended into early April.
- Autumn planting is preferred for broadleaved trees and shrubs, since roots will grow in warm spells and thus lessen the effect of any subsequent spring drought. In exposed sites or areas where winter gales are likely, spring planting may be preferable.
- Order as far in advance as possible to ensure the correct trees are available. Request that plants are delivered as close as possible to the planting date. It

is best to choose an established local nursery because they will usually have a reputation to maintain and your transport costs should be lower. In addition, the plants will be out of the ground for the minimum length of time.

- Wherever possible try to obtain plants grown from locally obtained seeds or cuttings (native provenance), since these will do better under local conditions and are more valuable for wildlife than imported stock.
- Try to be on hand when plants arrive so that you can ensure they are in good physical condition. Keep the roots covered at all times before planting to prevent damage and drying out. Whilst cold is unlikely to be harmful, hot sun and any form of drying such as an east wind, can very quickly cause damage or kill the plants.
- If immediate planting is not possible, dig a trench before delivery and store plants in this with the roots covered so they are kept moist and cool. Protect the plants from animals, including rabbits and hares.

Suggested Native Trees and Shrubs Suitable for Planting			
Alder	Cherry (Wild & Bird)	Guelder Rose	Rowan (Mountain Ash)
Aspen	Crab Apple	Hawthorn	Scots Pine
Beech	Dog Rose	Hazel	Spindle
Birch (Silver & Downy)	Elder	Holly	Willow (Crack, Goat & Grey)
Blackthorn	Field Maple	Lime (Small & large leaved)	White Poplar
Black Poplar		Oak (Sessile & Pedunculate)	Yew

For an extensive list of trees native to Wales, see Forest Research's [*Using Local Stock for Planting Native Trees and Shrubs*](#) (zones 303 and 304 apply).

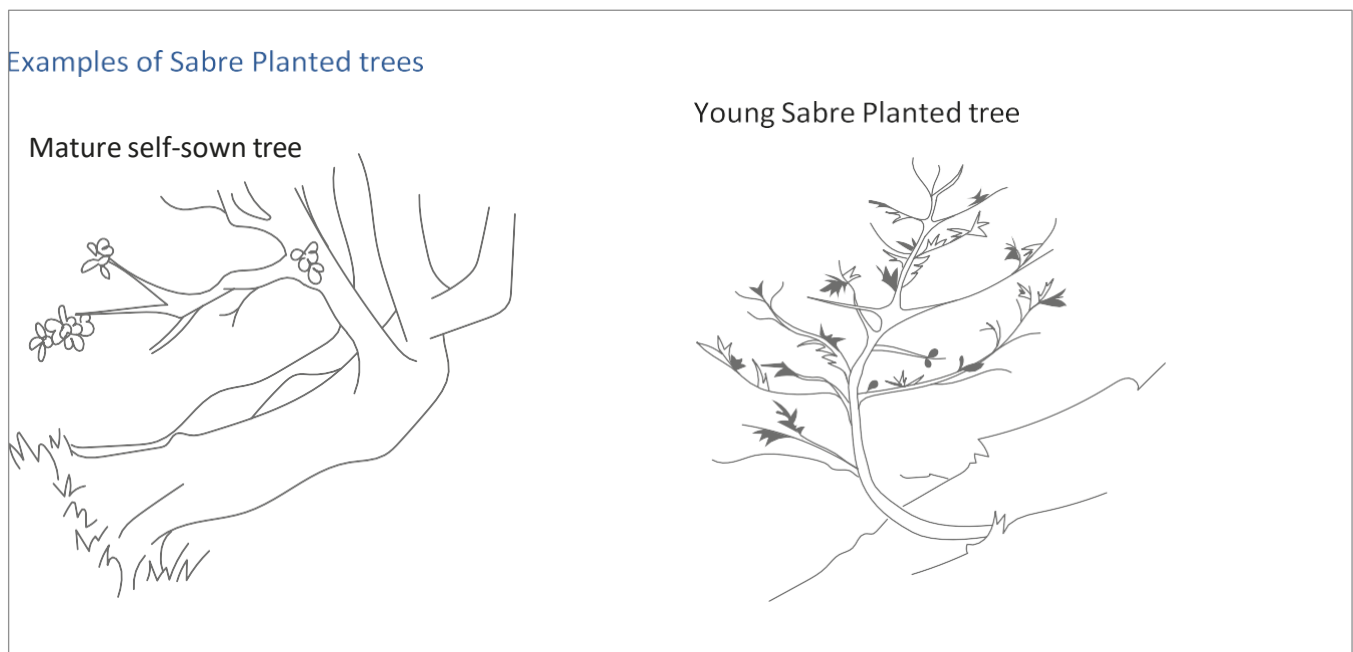

Spiral Rabbit Guards

Item Code: L019

Payment Rate: £0.58 each

This technical note describes the minimum standard of work required in order to receive payments for ‘Spiral Rabbit Guards’.

Any variation must be approved by the Welsh Government prior to starting the work. Spiral rabbit guards are the most widely used form of tree protection against rabbits and voles.

You must adhere to the following:

- Ensure each spiral rabbit guard is supported by a bamboo cane.

Do not:

- Use guards that are taller than the tree it is to protect at the time of planting.

Requirements and guidance in addition to the specifications above:

- Spiral rabbit guards are made from a plastic material and are available in three sizes, (45cm, 60cm and 75cm).
- Ideally the bamboo cane should be pushed into the ground next to the newly planted tree. The guard is then wound or spiralled around both tree and cane so that small mammals are excluded.

New Hedge Planting

Item Code: L020

Payment Rate: £9.39/m

This technical note describes the minimum standard of work required in order to receive payments for ‘New Hedge Planting’. Any variation must be approved by the Welsh Government prior to starting the work.

You must adhere to the following:

- Plant native trees and shrubs in a mix of at least three hedging species, with no one component of the mix comprising more than 75% of the total.
- Plant hedge plants that are at least 45-60cm high, which should have a strong leader shoot.
- Plant new hedgerows at a density of 7 plants per metre in a staggered double row, with 20cm between each row.
- Prevent new plants from being killed by shading out from excessive weed growth.
- Protect newly planted hedges from livestock.
- Replace any dead plants.
- Ensure there is at least 1m between new planting and protective fencing.

- Ensure that the hedge is able to grow to a 3m width. There must be a gap of at least 3m between double fences. Where a new hedge is planted beside a road, a 1.5m gap from the centre of the hedge to the fence is permissible. The fence must be located on the field side of the hedge.
- Obtain your neighbour's written consent to place a fence on their land if you are planting a new hedge on their boundary.

Do not:

- Plant any ash trees as part of any planting mix due to ash dieback disease (*Hymenoscyphus fraxineus*).
- Use trees and shrubs as strainers or fencing posts, or use them to support fencing wire, staples or netting.
- Cause damage to any existing historic hedge banks during ground preparation, planting or fencing.

Requirements and guidance in addition to the specifications above:

- Ensure that you have the appropriate Flood Risk Activity Permit if you are planting or fencing near a main river, flood plain or flood defence structure. Alternatively, ensure you have the appropriate Ordinary Water Course Consent if you are carrying out works near an ordinary watercourse. What may be considered a ditch may be an ordinary watercourse, so consent may be required. As such, the permit/ consent (or confirmation that a permit/ consent is not needed) should be retained and made available on request. See General Rules for more details.
- If undertaking any spraying as part of this activity ensure you have obtained any consents that may be necessary.
- Where Ffermio Bro activities include the installation of access furniture such as stiles or gates on a Public Right of Way, it is your responsibility to ensure you obtain approval under Section 147 of the Highways Act, 1980, from the appropriate Highway Authority.
- Ensure the best chances of survival, by planting new hedgerow plants in the winter months from November to March. Keep root balls damp during planting, and water liberally in dry spells until established.
- Select plants with well-developed root systems. Plants which are 3 – 4 years old are recommended
- Prepare the ground for planting by either rotovating, ploughing or digging over during the previous summer. Avoid damaging historic banks during ground preparation by digging manually.
- You may incorporate some well-rotted manure if planting hedge plants on poor soils.
- Plant locally common native species where possible. Plants should be derived from locally collected seed or cuttings if possible as these are likely to survive better and support more species of native wildlife.
- Control weeds by using a mulch of wood chippings or by securely pegging down a 500-gauge black polythene sheet, 1-2m wide at the base of the

transplants. Chemical control of grasses, thistles, docks and ragwort may be undertaken.

- Any chemical used must have a label recommendation for use on the listed species and for the intended method of application. All manufacturers label recommendations regarding application of the herbicide must be strictly adhered to.
- Encourage new growth by trimming the transplant back.
- Establish at least 1 – 2 hedgerow trees per 100m. Either plant new saplings (at least 1m tall), or identify existing plants that can develop into trees. It is sensible to tag the tree to avoid accidental damage when hedge trimming. Choose native tree species that grow well in local hedges, as they will contribute to an attractive landscape and can increase the wildlife value of the hedge.
- Spiral guards can be used to protect the hedge from rabbits, although in certain areas rabbit fencing may be a more effective deterrent.

Hedge Coppicing and Gapping Up

Item Code: L021

Payment Rate: £8.82/m

This technical note describes the minimum standard of work required in order to receive payments for 'Hedge Coppicing and Gapping-up'. Any variation must be approved by the Welsh Government prior to starting the work.

Please note, hedge trimming with a flail cutter does not meet the technical specification necessary to fulfil the requirement of coppicing the hedge at the level set out below. Hedge Coppicing and Gapping-up projects where a hedge has only been trimmed back, will be rejected.

Coppicing

Hedge coppicing must only be carried out on traditional hedgerows. It should not be carried out on lines of trees, such as riparian woodlands. Coppicing is generally undertaken when a hedge stem is too wide (more than 10cm in width) to lay properly. In some circumstances, the stems may be so wide that you may need to obtain a Felling Licence from Natural Resources Wales. It is your responsibility to check whether or not this is the case.

You must adhere to the following:

- Coppice the hedge to within 7.5cm or less of ground level to allow re-shooting.
- Retain all large, mature trees where undertaking hedgerow renovation work, particularly those with features such as holes, splits, cracks or dense ivy cover; as these provide roosting sites for bats.
- Plant native trees and shrubs in a mix of at least three hedging species, with no one component of the mix comprising more than 75% of the total.

- Plant hedge plants that are at least 45cm – 60cm high and have a strong leader shoot.
- Plant new hedgerows at a density of 7 plants per metre in a staggered double row, with 20cm between each row.
- Prevent new plants from being killed by shading out from excessive weed growth.
- Protect newly planted hedges from livestock.
- Replace any dead plants
- Ensure all redundant fencing or wire is removed.
- Ensure there is at least 1m between new planting and protective fencing.
- Ensure the hedge is able to grow to a 3m width. There must be a gap of at least 3m between double fences. Where a hedge is coppiced beside a road, a 1.5m gap from the centre of the hedge to the fence is permissible. The fence must be located on the field side of the hedge.
- Obtain your neighbour's written consent to place a fence on their land if you are planting a new hedge on their boundary.

Do not:

- Plant ash trees as part of any planting mix due to ash dieback disease (*Hymenoscyphus fraxineus*), in any planting mix, either for woodlands or when establishing or restoring hedgerows.
- Cause damage to any existing hedge banks during ground preparation, planting or fencing.
- Use trees and shrubs as strainers or fencing posts, or use them to support fencing wire, staples or netting.

Requirements and guidance in addition to the specifications above:

- Depending on the volume of timber felled you may need to obtain a felling licence from Natural Resources Wales.
- Ensure that you have the appropriate Flood Risk Activity Permit if you are planting or fencing near a main river, flood plain or flood defence structure. Alternatively, ensure you have the appropriate Ordinary Water Course Consent if you are carrying out works near an ordinary watercourse. What may be considered a ditch may be an ordinary watercourse, so consent may be required. As such, the permit/consent (or confirmation that a permit/consent is not needed) should be retained and made available on request. See General Rules for more details.
- If undertaking any spraying as part of this activity ensure you have obtained any consents that may be necessary.
- Where Ffermio Bro activities include the installation of access furniture such as stiles or gates on a Public Right of Way, it is your responsibility to ensure you obtain approval under Section 147 of the Highways Act, 1980, from the appropriate Highway Authority.
- Carry out hedge restoration work between dates permitted by Cross Compliance rules.

- Restricting the hedge restoration dates further to between November and March will be even more beneficial to wildlife such as dormice.
- Ensure the best chances of survival, by planting new hedgerow plants in the winter months from November to March. Keep root balls damp during planting, and water liberally in dry spells until established.
- An additional 1 metre at the base between hedge and fence (on top of the minimum 3 metre width) will create additional wildlife habitat.
- Increasing the species mix beyond the minimum requirement of a 3 species mix will provide a greater selection of food sources for wildlife.
- Select plants with well-developed root systems. Plants which are 3 – 4 years old are recommended.
- Holly and blackthorn are both suitable species to use. Prepare the ground for planting by either rotovating or digging over during the previous summer. Avoid damaging historic banks during ground preparation by digging manually.
- You may incorporate some well-rotted manure if planting hedge plants on poor soils.
- Plant locally common native species where possible. Plants should be derived from locally collected seeds or cuttings if possible as these are likely to survive better and support more species of native wildlife.
- No one component of the mix should comprise more than 75% of the total.
- In previously un-coppiced hedges gaps should be thoroughly cleared of vegetation and hedges cut back to allow healthy growth on both sides.
- Control weeds by using a mulch of wood chippings or by securely pegging down a 500-gauge black polythene sheet, 1m – 2m wide at the base of the transplants. Chemical control of grasses, thistles, docks and ragwort may be undertaken. Any chemical used must have a label recommendation for use on the listed species and for the intended method of application. All manufacturers label recommendations regarding application of the herbicide must be strictly adhered to.
- Encourage new growth by trimming the transplant back.
- Establish at least 1 – 2 hedgerow trees per 100m. Either plant new saplings (at least 1m tall), or identify existing plants that can develop into trees. It is sensible to tag the tree to avoid accidental damage when hedge trimming. Choose native tree species that grow well in local hedges, as they will contribute to an attractive landscape and can increase the wildlife value of the hedge.
- Spiral guards can be used to protect the hedge from rabbits, although in certain areas rabbit fencing may be a more effective deterrent.
- Retain all large mature trees where undertaking hedgerow renovation work, as these can provide roosting sites for bats.
- Where work is required to a tree that has been identified as a bat roost (either because bats are known to be present or where positive signs of bat use have been found), a Habitats Regulations licence from Natural Resources Wales must be obtained.

Hedge Laying

Item Code: L022

Payment Rate: £15.38/m

This technical note describes the minimum standard of work required in order to receive payments for 'Hedge Laying'. Any variation must be approved by the Welsh Government prior to starting the work.

You must adhere to the following:

- Ensure that all redundant fencing or wire is removed.
- Lay the hedge by partially cutting through suitable stems at ground level, at an angle of approximately 30°.
- Lay the cut stems as close to ground level as possible, and secure in place with stakes.
- Retain all large, mature trees where undertaking hedgerow renovation work, particularly those with features such as holes, splits, cracks or dense ivy cover as these provide roosting sites for bats.
- Ensure there is at least 1m between new planting and protective fencing.
- Ensure that the hedge is able to grow to a 3m width. There must be a gap of at least 3m between double fences. Where a new hedge is planted beside a road, a 1.5m gap from the centre of the hedge to the fence is permissible. The fence must be located on the field side of the hedge.
- You must ensure the entire width of the hedge is laid. If part of the width of a hedge falls outside your boundary, you should not include this hedge, unless you obtain the written consent from your neighbour to do so.
- Obtain your neighbour's written consent to place a fence on their land if you are planting a new hedge on their boundary.

Do not:

- Use wire or baler twine to secure either the stakes or cut stems.
- Plant any ash trees as part of any planting mix due to ash dieback disease (*Hymenoscyphus fraxineus*), in any planting mix, either for woodlands or when establishing or restoring hedgerows.
- Cause damage to any existing hedge banks during ground preparation, planting or fencing.
- Use trees and shrubs as strainers or fencing posts, or use them to support fencing wire, staples or netting.

Requirements and guidance in addition to the specifications above:

- Depending on the volume of timber felled you may need to obtain a felling licence from Natural Resources Wales.
- Ensure that you have the appropriate Flood Risk Activity Permit if you are planting or fencing near a main river, flood plain or flood defence structure. Alternatively, ensure you have the appropriate Ordinary Water Course Consent if you are carrying out works near an ordinary water course. What

may be considered a ditch may be an ordinary watercourse, so consent may be required. As such, the permit/consent (or confirmation that a permit/consent is not needed) should be retained and made available on request. See General Rules for more details.

- If undertaking any spraying as part of this activity ensure you have obtained any consents that may be necessary.
- Where Ffermio Bro activities include the installation of access furniture such as stiles or gates on a Public Right of Way, it is your responsibility to ensure you obtain approval under Section 147 of the Highways Act, 1980, from the appropriate Highway Authority.
- Carry out hedge restoration work between dates permitted by Cross Compliance rules.
- Restricting the hedge restoration dates further to between November and March will be even more beneficial to wildlife such as dormice.
- Stems for laying should be about 5cm – 10cm thick at the base, and 2.5m – 3.5m in height. Beyond this stage coppicing should be considered as a more suitable alternative.
- An additional 1 metre at the base between hedge and fence (on top of the minimum 3 metre width) will create additional wildlife habitat.
- If planting any gaps, using the widest selection of species available will provide a greater selection of food sources for wildlife.
- Aim to lay hedges in the winter months between November and March.
- Whenever possible follow local traditional methods and customs.
- In the interest of biodiversity, remove only as much elder as is necessary and cut back any bramble, briar or other climbing growth where this impedes laying operations.
- Hedge laying should aim to be upslope and in the same direction wherever possible.
- Maintain existing ash trees where possible.
- Retain all large mature trees where undertaking hedgerow renovation work, as these can provide roosting sites for bats.
- Where work is required to a tree that has been identified as a bat roost (either because bats are known to be present or where positive signs of bat use have been found), a Habitats Regulations licence from Natural Resources Wales must be obtained.

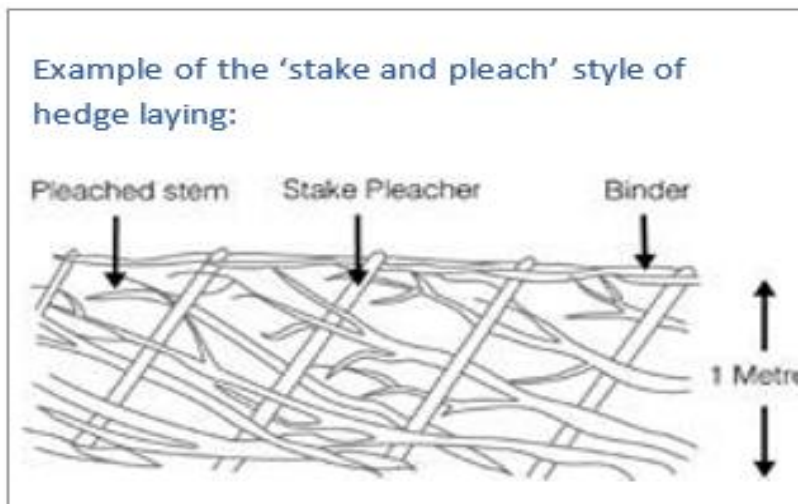

Cross Drains

Item Code: L023

Payment Rate: £178.20/m

This technical note describes the minimum standard of work required in order to receive payments for 'Cross Drains'. Any variation must be approved by the Welsh Government prior to starting the work.

The purpose of a cross drain is to help separate clean and dirty water on and around farmyards and tracks. Many streams and rivers in Wales are affected by pollution from agricultural runoff, impacting on biodiversity, fisheries and drinking water quality. Preventing clean water from diluting dirty water at farmyard level means that clean water can be captured for later use, and dirty water remains at more manageable quantities to be properly captured and dealt with appropriately.

Cross drains can be used to intercept clean water from clean tracks and yards upslope of the dirty track/yard areas. This clean water can be diverted into an existing ditch, swale, or sediment trap. Alternatively, cross drains can be used to intercept foul water downslope of yards/ tracks. This foul water must be diverted into an appropriate slurry store. The open channel of the cross drain is easy to clear of accumulated silt and debris. Foul water must not be diverted into watercourses, drains or onto land.

If you are installing cross drains in farmyards to intercept clean water, you should consider whether you also need to apply for Option 910 Rainwater Goods – Guttering and Option 911 Rainwater Goods – Downpipes.

You can apply for multiple cross drains to span the whole width of wider tracks/yard areas or to install multiple tiers of cross drains across tracks carrying large volumes of water horizontally.

You must adhere to the following:

- Install purposely constructed cross drains, which can be cleared of debris and which can support slow moving heavy machinery.
- Ensure that all cross drains consist of new materials.
- Concrete work should be carried out in accordance with the relevant British Standards BS 8000 and BS 8500, as amended.
- Ensure that clean water from the cross drain is directed to a stable drainage outlet such as a ditch, swale or sediment trap.
- Ensure that foul water is discharged into an appropriate slurry store.

Requirements and guidance in addition to the specifications above:

- Ensure that you have the appropriate Flood Risk Activity Permit if you are planting or fencing near a main river, flood plain or flood defence structure. Alternatively, ensure you have the appropriate Ordinary Water Course Consent if you are carrying out works near an ordinary water course. What may be considered a ditch may be an ordinary watercourse, so consent may be required. As such, the permit/consent (or confirmation that a permit/consent is not needed) should be retained and made available on request. See General Rules for more details.

How to install a cross drain – best practice

The work will include the purchase and installation of a polychannel drainage system with grating. The channel once installed should be able to support the weight of slow moving heavy machinery, and can easily be cleared of accumulated silt and debris.

- Excavate a trench across the width of the track or along part of the farm yard, allowing sufficient depth and width for the concrete bed and surround.
- Make sure the outlet of the trench runs into a suitable ditch or swale.
- Slope the bed of the trench towards the outlet, following the depth of the proposed channel.
- Ensure that any arrows on the side of the channel point towards the outlet i.e. in the direction of flow.
- Set levels and lay out the channels alongside the trench, always starting at the outlet point.
- Pour bedding – begin at the outlet position, a good quality concrete bedding should be poured into the trench.
- Working away from the outlet, lower the channels into position following the manufactures instructions.
- Check alignment of channel.
- The grating should be loosely laid and wrapped in plastic, spanning the channel joints to ensure a clean final installation.
- The concrete surround can now be poured into the trench, taking care not to disturb the line of the run. This should finish 3mm above the channel and grating top surface.
- Once the concrete has set, lift out gratings and remove the protective plastic.

- To support heavy slow moving machinery a minimum concrete bed and surround of 200mm is required, unless specified otherwise with polychannel installation instructions.



Kerbing

Item Code: L024

Payment Rate: £52.94/m

This technical note describes the minimum standard of work required in order to receive payments for 'Kerbing'. Any variation must be approved by the Welsh Government prior to starting the work.

What is the purpose of this activity?

The purpose of installing kerbs on and around farmyards and alongside tracks is to help separate clean and dirty water. Many streams and rivers in Wales are affected by pollution from agricultural run-off, impacting on biodiversity, fisheries and drinking water quality.

Kerbs can be used to divert dirty water away from on-yard gullies or other areas where it may contribute to run-off and potential pollution.

The dirty water can then be channelled into an appropriate store or slurry store.

Alternatively, kerbs can be used to divert clean water away from dirty track/yard areas. Preventing clean water from diluting dirty water at farm yard level means that clean water can be captured for later use, and dirty water remains at more manageable quantities to be appropriately captured in slurry stores and dealt with properly.

If you are installing kerbs in farmyards to intercept clean water, you should consider whether you also need to apply for Option 910 Rainwater Goods – Guttering and Option 911 Rainwater Goods – Downpipes.

You must adhere to the following:

- Install kerbing with new kerbstones measuring 900mm x 255mm x 125mm (half battered)
- Concrete work should be carried out in accordance with the relevant British Standards BS 8000 and BS 8500, as amended.
- Ensure that clean water from the kerbing is directed to a stable drainage outlet such as a ditch, swale or sediment trap.
- Ensure that foul water is discharged into an appropriate slurry store.

Requirements and guidance in addition to the specifications above:

- Ensure that you have the appropriate Flood Risk Activity Permit if you are planting or fencing near a main river, flood plain or flood defence structure. Alternatively, ensure you have the appropriate Ordinary Water Course Consent if you are carrying out works near an ordinary watercourse. What may be considered a ditch may be an ordinary watercourse, so consent may be required. As such, the permit/consent or confirmation a permit/consent is not needed, should be retained and made available on request. See General Rules for more details.

Kerbing – best practice

- Kerbing is likely to be more stable if a trench is excavated in the existing track to a minimum depth of 300mm.
- Fill with concrete and key in pre-cast concrete kerb stones protruding from the surface.
- Tamper the concrete on the outer side to the top edge of the kerb stone.
- Leave concrete on the inner side (the side that will divert the water) flat, below the top of the kerbstone.

Sleeping Policemen

Item Code: L025

Payment Rate: £38.60/m

This technical note describes the minimum standard of work required in order to receive payments for ‘Sleeping Policemen’. Any variation must be approved by the Welsh Government prior to starting the work.

What is the purpose of this activity?

The purpose of a sleeping policeman is to help separate clean and dirty water on and around farmyards and tracks. Many streams and rivers in Wales are affected by pollution from agricultural run-off, impacting on biodiversity, fisheries and drinking water quality.

Preventing clean water from diluting dirty water at farm yard level means that clean water can be captured for later use, and dirty water remains at more manageable quantities to be appropriately captured in slurry stores and dealt with properly.

Sleeping policemen can be used to intercept clean water from clean tracks and yards upslope of the dirty track/yard areas. Alternatively, they can be used to intercept foul water downslope of yards/tracks. This foul water must be diverted into an appropriate store or slurry store.

Installing sleeping policemen across farm tracks can also intercept and divert surface run-off, reducing flow rates at down slope locations and therefore helping to prevent erosion on farm track surfaces. By taking action to slow run-off you can reduce water damage to tracks, minimise soil erosion and reduce the risk of water pollution.

If you are installing sleeping policemen in farmyards to intercept clean water, you should consider whether you also need to apply for Option - Rainwater Goods – Guttering and Option - Rainwater Goods – Downpipes.

You must adhere to the following:

- Create sleeping policemen to a height of at least 150 mm above track level, which can support slow moving heavy machinery.
- Concrete work should be carried out in accordance with the relevant British Standards BS 8000 and BS 8500, as amended.
- Ensure that clean water from the sleeping policemen is directed to a stable drainage outlet such as a ditch, swale or sediment trap.
- Ensure that foul water is discharged into an appropriate slurry store.

Requirements and guidance in addition to the specifications above:

- Ensure that you have the appropriate Flood Risk Activity Permit if you are planting or fencing near a main river, flood plain or flood defence structure. Alternatively, ensure you have the appropriate Ordinary Water Course Consent if you are carrying out works near an ordinary water course. What may be considered a ditch may be an ordinary watercourse, so consent may be required. As such, the permit/consent (or confirmation
- that a permit/consent is not needed) should be retained and made available on request. See General Rules for more details.
- Sleeping policemen are likely to be more stable if a trench is excavated in the existing track to a minimum depth of 100mm, and then key concrete into the trench and up to a height of at least 150mm.

Rainwater Goods (Guttering)

Item Code: L026

Payment Rate: £17.42/m

This technical note describes the minimum standard of work required in order to receive payments for 'Rainwater Goods – Guttering'. Any variation must be approved by the Welsh Government prior to starting the work.

What is the purpose of this activity?

The purpose of new rainwater goods is to help separate clean rain water from dirty water on and around farmyards. Many streams and rivers in Wales are affected by pollution from agricultural run-off, impacting on biodiversity, fisheries and drinking water quality. Preventing rainwater from diluting dirty water at farmyard level means that dirty water remains at more manageable quantities to be appropriately captured in slurry stores and dealt with properly.

Guttering can be used to intercept and capture rainwater from farm building roofs. This clean water can be diverted into an existing clean water drain or discharged to an existing ditch, swale, or sediment trap. Alternatively it may be captured for later on-farm use.

Payments are available for the provision and installation of new rainwater goods (guttering and downpipes), where existing ineffective or non-existent rainwater goods discharge clean water onto fouled yard areas.

This option is for existing buildings, traditional or modern, within the farmyard that currently do not have rainwater goods or which have existing rainwater goods that are beyond their serviceable life and need replacement. Non-agricultural buildings and houses are not eligible.

Rainwater goods on proposed new buildings are not eligible for a grant as they should already have rainwater goods built into the design.

Listed buildings are not eligible for this option.

You must adhere to the following:

- Use guttering, typically 150mm half round PVC guttering, and appropriate brackets. All goods must satisfy all relevant British Standards, as amended, such as BS EN 607, BS EN12200 and BS EN 1462.
- Installation work should satisfy all relevant British Standards, as amended, such as BS 5502 and BS EN1917.
- Ensure that all rainwater goods consist of new materials.

Do not:

- Install plastic rainwater goods on Listed Buildings.

Rainwater Goods – Downpipe

Item Code: L027

Payment Rate: £13.73/m

This technical note describes the minimum standard of work required in order to receive payments for 'Rainwater Goods – Downpipe'. Any variation must be approved by the Welsh Government prior to starting the work.

What is the purpose of this activity?

The purpose of new rainwater goods is to help separate clean rain water from dirty water on and around farmyards. Many streams and rivers in Wales are affected by pollution from agricultural run-off, impacting on biodiversity, fisheries and drinking water quality. Preventing rainwater from diluting dirty water at farm yard level means that dirty water remains at more manageable quantities to be appropriately captured in slurry stores and dealt with properly.

Downpipes can be used to intercept and capture rain water from farm building roofs. This clean water can be diverted into an existing clean water drain or discharged to an existing ditch, swale, or sediment trap. Alternatively, it may be captured for later on-farm use.

Payments are available for the provision and installation of downpipes where existing ineffective or non-existent rainwater goods discharge clean water onto fouled yard areas.

This option is for existing buildings, traditional or modern, within the farmyard that currently do not have rainwater goods or which have existing rainwater goods that are beyond their serviceable life and need replacement. Non-agricultural buildings and houses are not eligible.

Rainwater goods on proposed new buildings are not eligible for a grant as they should already have rainwater goods built into the design.

Listed buildings are not eligible for this option.

You must adhere to the following:

- Use 110mm downpipe and brackets that satisfy all relevant British Standards, as amended, such as BS EN 607, BS EN12200 and BS EN 1462.
- Installation work should satisfy all relevant British Standards, as amended, such as BS 5502 and BS EN1917.
- Ensure that all rainwater goods consist of new materials.
- Any underground drainage works should comply with all relevant British Standards, as amended, such as BS 8000, BS EN 752 and BS EN 1610.

Do not:

- Install plastic rainwater goods on Listed Buildings.

Requirements and guidance in addition to the specifications above:

- Where rainwater goods are at risk of being damaged by livestock, suitable protection should be installed.

New Hedge Planting for Pollinators

Item Code: L028

Payment Rate: £9.39/m

This technical note describes the minimum standard of work required in order to receive payments for 'New Hedge Planting'.

Any variation must be approved by the Welsh Government prior to starting the work.

You must adhere to the following:

- Plant native trees and shrubs in a mix of at least three hedging species. At least 90% of the planting mix must comprise of the following species; blackthorn, hawthorn, crab apple, wild plum or wild cherry. No one component of the mix should comprise more than 75% of the total.
- Plant hedge plants that are at least 45-60cm high which should have a strong leader shoot.
- Plant new hedgerows at a density of 7 plants per metre in a staggered double row, with 20cm between each row.
- Prevent new plants from being killed by shading out from excessive weed growth.
- Protect newly planted hedges from livestock.
- Replace any dead plants.
- Ensure there is at least 1m between new planting and protective fencing.
- Ensure that the hedge is able to grow to a 3m width. There must be a gap of at least 3m between double fences.

Do not:

- Plant any ash trees as part of any planting mix due to ash dieback disease (*Hymenoscyphus fraxineus*).
- Cause damage to any existing historic hedge banks during ground preparation, planting or fencing.
- Use trees and shrubs as strainers or fencing posts, or use them to support fencing wire, staples or netting.

Requirements and guidance in addition to the specifications above:

- Ensure that you have the appropriate Flood Risk Activity Permit if you are planting or fencing near a main river, flood plain or flood defence structure. Alternatively, ensure you have the appropriate Ordinary Water Course Consent if you are carrying out works near an ordinary water course. What may be considered a ditch may be an ordinary watercourse, so consent may be required. As such, the permit/consent, or confirmation that a permit/consent is not needed, should be retained and made available on request.

- If undertaking any spraying as part of this activity ensure you have obtained any consents that may be necessary.
- Where Ffermio Bro activities include the installation of access furniture such as stiles or gates on a Public Right of Way, it is your responsibility to ensure you obtain approval under Section 147 of the Highways Act, 1980, from the appropriate Highway Authority.
- Ensure the best chances of survival, by planting new hedgerow plants in the winter months from November to March. Keep root balls damp during planting, and water liberally in dry spells until established.
- Select plants with well-developed root systems. Plants which are 3 – 4 years old are recommended
- Prepare the ground for planting by either rotovating, ploughing or digging over during the previous summer. Avoid damaging historic banks during ground preparation by digging manually.
- You may incorporate some well-rotted manure if planting hedge plants on poor soils.
- Plant locally common native species where possible. Plants should be derived from locally collected seed or cuttings if possible as these are likely to survive better and support more species of native wildlife.
- Control weeds by using a mulch of wood chippings or by securely pegging down a 500-gauge black polythene sheet, 1-2m wide at the base of the transplants. Chemical control of grasses, thistles, docks and ragwort may be undertaken.
- Any chemical used must have a label recommendation for use on the listed species and for the intended method of application. All manufacturers label recommendations regarding application of the herbicide must be strictly adhered to.
- Encourage new growth by trimming the transplant back.
- Establish at least 1 – 2 hedgerow trees per 100m. Either plant new saplings (at least 1m tall), or identify existing plants that can develop into trees. It is sensible to tag the tree to avoid accidental damage when hedge trimming. Choose native tree species that grow well in local hedges, as they will contribute to an attractive landscape and can increase the wildlife value of the hedge.
- Spiral guards can be used to protect the hedge from rabbits, although in certain areas rabbit fencing may be a more effective deterrent.

Dry Stone Wall Restoration

Item Code: L029

Payment Rate: £33.42/m²

This technical note describes the minimum standard of work required in order to receive payments for 'Dry Stone Wall Restoration'.

Any variation from the standards set out must be approved by the Welsh Government prior to starting the work.

Dry stone walls are an important landscape feature which can be an important record of historical land use, as well as important features for biodiversity and stock shelter.

Dry stone walls may not follow straight lines, a factor that contributes to both their landscape and historic importance.

Vehicle damage, theft and rubbing by livestock can all cause damage to the wall.

You must adhere to the following:

Restore degraded dry stone walls so that the height and the line of the restored wall follow that of the existing feature. Best practice guidelines for restoring dry stone walls are described below.

All stone used to restore dry stone walls must match the stones in existing features.

Retain and/or rebuild all stone stiles, sheep creeps, culverts and other traditional features.

All surplus stone and earth should be removed from site on completion and the adjacent ground returned to the original vegetation.

Requirements and guidance in addition to the specifications above:

Where Ffermio Bro activities include the installation of access furniture such as stiles or gates on a Public Right of Way, it is your responsibility to ensure you obtain approval

under Section 147 of the Highways Act, 1980, from the appropriate Highway Authority.

Local stone should be used wherever possible, but do not raid stone from inappropriate places such as ruins or other walls. Imported stone should be of local provenance where possible.

Decide if top wiring is to be incorporated before wall restoration commences.

Footings/foundations – the first layer of large stones at the base. Footings should consist of two rows of the largest stones available laid in a trench 15cm to 30cm deep. In very soft conditions a deeper foundation may be required. The gaps at the centre of the footings should be packed with irregular stones. The footings should be about 7.5cm wider than the base of the wall. When rebuilding a wall the old footings must be carefully checked and replaced if they are insecure, out of line, tilted, or if the stone has crumbled.

Batter – the inward taper of the wall from base to top. The wall should taper evenly on both sides to the top. The amount of batter may depend on the type of stock grazing next to the wall.

For a 1.3m high wall, the base should be 70cm to 90cm wide, tapering to a width of 30cm to 40cm under the coping, depending on the size and type of stone of local style.

Face stones – Walls should be built with two even faces which follow the batter. Face stones should be placed with the following rules in mind:

use the largest stones at the bottom, grading to the smallest at the top

build in even courses (unless style of building is not coursed)

place stones with their longest dimension running into the wall

each gap between stones must be securely covered by a stone in the next course so that there are no vertical breaks in the wall

stones must not slope into the wall

the face must be even with no stones protruding from the wall except 'through stones'

stones must be laid horizontally along the line of the wall even when walling on a slope

wedges (small stones to secure larger stones) must only be placed on the inside and not the face of the wall.

Hearting – small stones used as filling and packing. Gaps in the middle of the wall between face stones must be packed with smaller, irregular stones. Soil and other fine material must not be used as it will wash out. Each course must be hearted before starting the next.

Through stones – heavy, large stones placed at intervals to tie the sides together. Ideally two rows of 'through stones' should be placed at 45cm and 90cm above ground level with 100cm between adjacent 'through stones' for a 1.3m high wall.

If there is insufficient suitable stone a single row of 'through stones' should be placed at between 60cm and 75cm above ground level. The 'through stones' must be at least the full width of the wall and may protrude a few centimetres from the wall.

Coping – top stones to give weight and protection. The top of the wall should be built to an even height and properly hearted. Coping stones must be the full width of the wall and should be 20cm to 30cm high. Normally, stones that are wider than the wall should be trimmed but where there is no grazing stock on one side the coping stones may protrude up to 5cm on that side. The coping stones must be carefully placed so that they pack tightly together and provide weight onto every top face stone.

Wall heads – vertical ends to a length of wall. They should be built of alternate courses of ties ('through stones' tying both sides of the wall together) and runners (long stones placed in line with the face). The end coping stone must be large and heavy enough to support the remainder of the coping. There must not be any stones protruding from the wall head which could be rubbed by stock.

Building a retaining wall – Retaining walls are built into the face of a bank to prevent soil moving down slope. Retaining walls should be built in the same way as free standing walls with two faces. The inner face need not be even, as is required for a free standing wall. The inner face should be vertical, with a normal batter on the outer face. Where necessary, provision should be made for drainage.

Mortar – Where walls are to be built next to busy roads, particularly those used by heavy vehicles, it may be necessary to use mortar to stop the wall being damaged by the vibration. In such situations, the hearting throughout the wall and the coping stones could be mortared, leaving an external appearance of a dry stone wall. Where coping stones are likely to be dislodged because of people climbing the wall (e.g. next to a picnic site) the coping stones can be mortared. This should not be done for at least one year after a wall is built to allow it to settle.

Top wiring – Wooden posts can be set into the wall to support a line of barbed along the length of the wall to prevent stock climbing the wall and causing damage.

The finished wall must be solid with tight facing stones, on impact there should be no movement of the wall or heartings.

Earth Bank Restoration

Item Code: L030

Payment Rate: £10.89/m²

This technical note describes the minimum standard of work required in order to receive payments for 'Earth Bank Restoration'.

Any variation from the standards set out must be approved by the Welsh Government prior to starting the work.

Earth banks are an important landscape feature which can be an important record of historical land use, as well as important features for biodiversity and stock shelter.

They may or may not have hedgerows planted on top. Old hedges and banks may not follow straight lines, a factor that contributes to both their landscape and historic importance.

Prolonged bad weather, trampling by livestock and burrowing by rabbits can all cause damage to the bank.

You must adhere to the following:

- Restore degraded earth banks so that the height and the line of the restored bank follow that of the existing feature. Best practice guidelines for restoring earth banks are described below.
- Ensure that grazing animals do not damage restored banks.

- Fill any trenches or pits from which soil has been taken with loose earth or discarded turfs. The area on both sides of the newly restored bank should be left level and tidy.

Requirements and guidance in addition to the specifications above:

- Where Ffermio Bro activities include the installation of access furniture such as stiles or gates on a Public Right of Way, it is your responsibility to ensure you obtain approval under Section 147 of the Highways Act, 1980, from the appropriate Highway Authority.
- Ideally, turfs cut from the adjacent field should be used to re-surface the earth bank, however, if natural regeneration is taking place when the claim is submitted and geo-tagged 'after' photos show this, that would be acceptable.
- Excavate all loose turf and earth from the area to be repaired until a firm foundation is available. Retain loose soil for use during rebuilding. The cleaned area should slope inwards slightly as well as being wider at the top than the bottom (v-shaped or trapezoid in face view), as this will allow the repair work to key into the existing bank on both sides. Tamp down the newly formed foundation with a suitable hand tool to achieve as firm a surface as possible. (See diagram 1).
- Replacement turfs, where used, should be cut from the field at the foot of the bank. Smaller turfs are more likely to knit together once they have been placed in their new position.
- Turfs less than 30cm square are easier to handle and turfs cut on a slant will knit together more easily than those with squared edges (See diagram 1).
- Proper backing for the new turfs must be provided before they are placed in position. Use the previously retained earth together with any loose soil left in the trench, from which the newly cut turfs were removed. Keep the backing well filled and slightly above the level of each course of turfs as they are put in place. The backing should be keyed into the old bank and tamped down firmly to reduce the risk that heavy rain or a severe frost will cause the new work to slip away. (See diagram 2).
- Best practice is to place turfs in a series of layers or courses. Break the joints between alternate courses as in brickwork. Turfs should slope inwards slightly with each turf tamped well down to eliminate as far as possible the visible joints between the courses. Set each course very slightly back from the course below by about 1-2.5cm. Together with the inward slope this will allow for some movement outwards when tamping down, and for rainwater to run into the root areas of each turf. (See diagrams 1 & 2).
- Finish with loose soil on the top of the bank, to just above the level of the turf to allow for settlement. The batter (the slope back from the vertical) may be varied according to the site and conditions, but the base of the bank will normally be some 45–60cm wider than the top.
- Infilling any large gaps with well compacted soil before replacing the surface turf will help prevent further erosion taking place. The short turf covering a well-maintained earth bank helps to maintain the shape of the structure.

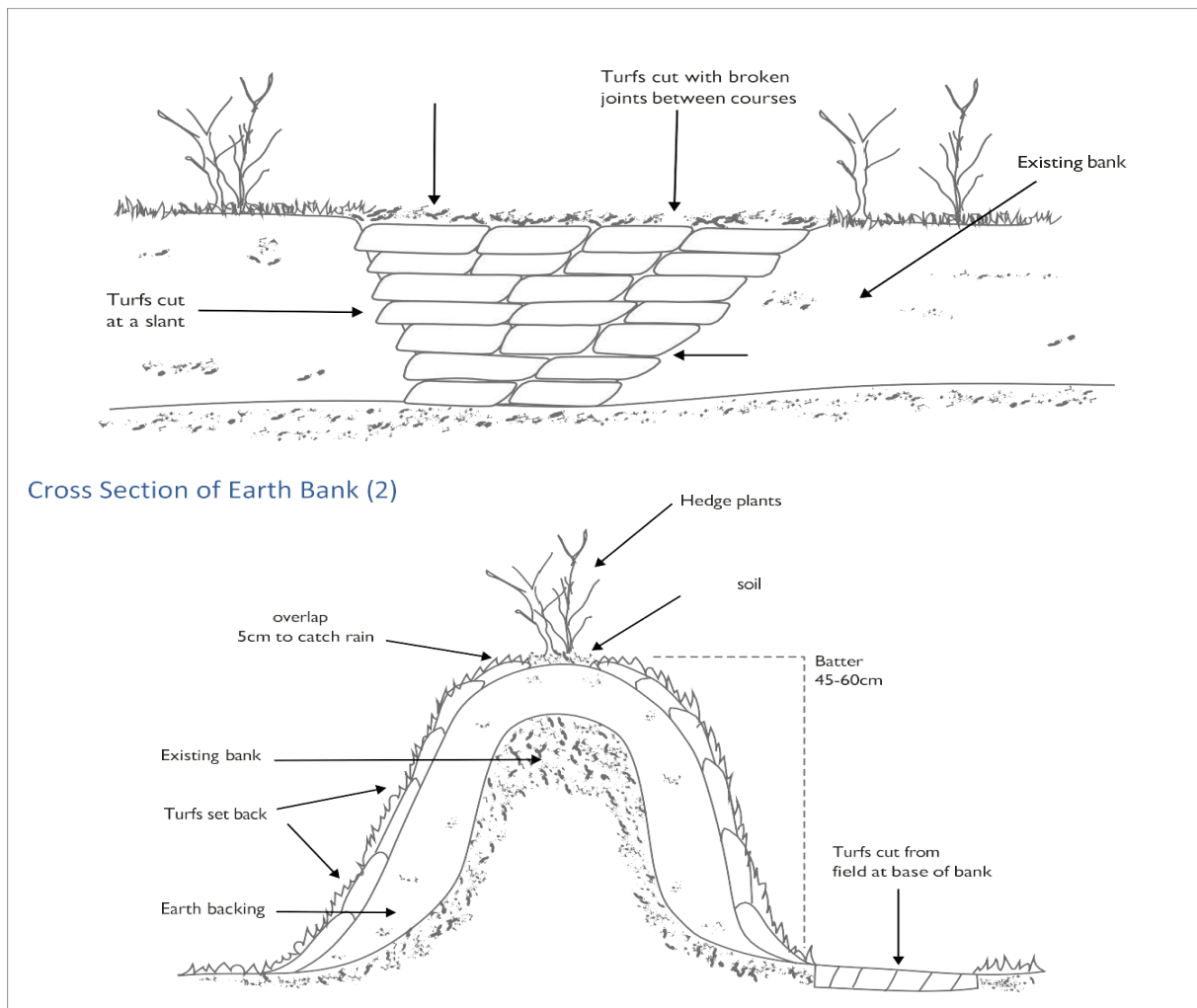

Stone-Faced Earth Bank Restoration Item Code: L031

Payment Rate: £28.10 /m2

This technical note describes the minimum standard required in order to receive payments for 'Stone Faced Earth Banks Restoration'. Any variation from the standards set out must be approved by the Welsh Government prior to starting the work.

Stone faced earth banks are an important landscape feature which can be an important record of historical land use, as well as important features for biodiversity and stock shelter. They may or may not have hedgerows planted on top. Old hedges and banks may not follow straight lines, a factor that contributes to both their landscape and historic importance. Prolonged bad weather, trampling by livestock and burrowing by rabbits can all cause damage to stonework and underlying bank.

You must adhere to the following:

- Restore degraded stone-faced banks so that the height and the line of the restored bank follow that of the existing feature. Best practice guidelines for restoring stone faced earth banks are described below.
- Ensure that grazing animals do not damage restored banks.
- All surplus stone and earth should be removed from site on completion and the adjacent ground returned to the original vegetation.

Requirements and guidance in addition to the specifications above:

- Where Ffermio Bro activities include the installation of access furniture such as stiles or gates on a Public Right of Way, it is your responsibility to ensure you obtain approval under Section 147 of the Highways Act, 1980, from the appropriate Highway Authority.
- Local stone should be used wherever possible, but do not raid stone from inappropriate places such as old ruins or other walls.
- **Footings and Foundations** – Loose stones and earth fill must be cleared out until a good, sound earth bank is encountered. Replace the previously removed stones and earth in stages. During this work the earth infill should be allowed to settle at various stages before completion. This settling process will be sped up if it rains during rebuilding.
- Where complete restoration is specified, all of the stone facings should be removed down to the foundations and rebuilt from this level. Sound foundations or footings will consist of at least one row of the largest stones available, laid in a trench 15–20cm deep. Gaps between footings should be packed with smaller stones. The footings themselves should be at least 7.5cm wider than the base of the wall. (See diagram).
- **Batter** – Batter is the term given to the inward taper of the wall from the base to the top. If the stone facing is 70–90 cm wide at the base it should be 30–40 cm wide at the top. There must be sufficient batter to ensure a stable wall. The batter can be straight, 'A'-shaped or a concave depending upon the local style.
- **Drainage** – Where surface water runoff is liable to endanger the stability of the wall, a 40–60cm deep drain should be installed as shown in the diagram. Pipes should be laid in the trench bottom before refilling with loose stone.
- **Mortar** – Where stone faced earth banks are built next to busy roads or picnic sites, it may be necessary to use lime mortar in places, especially between the coping stones on the top. Mortar should not be used throughout the structure as this can cause drainage problems. The external appearance should be of a dry stone wall.
- Once restored, stone-faced earth banks must be regularly maintained to prevent deterioration.

Stone Faced Earth Banks

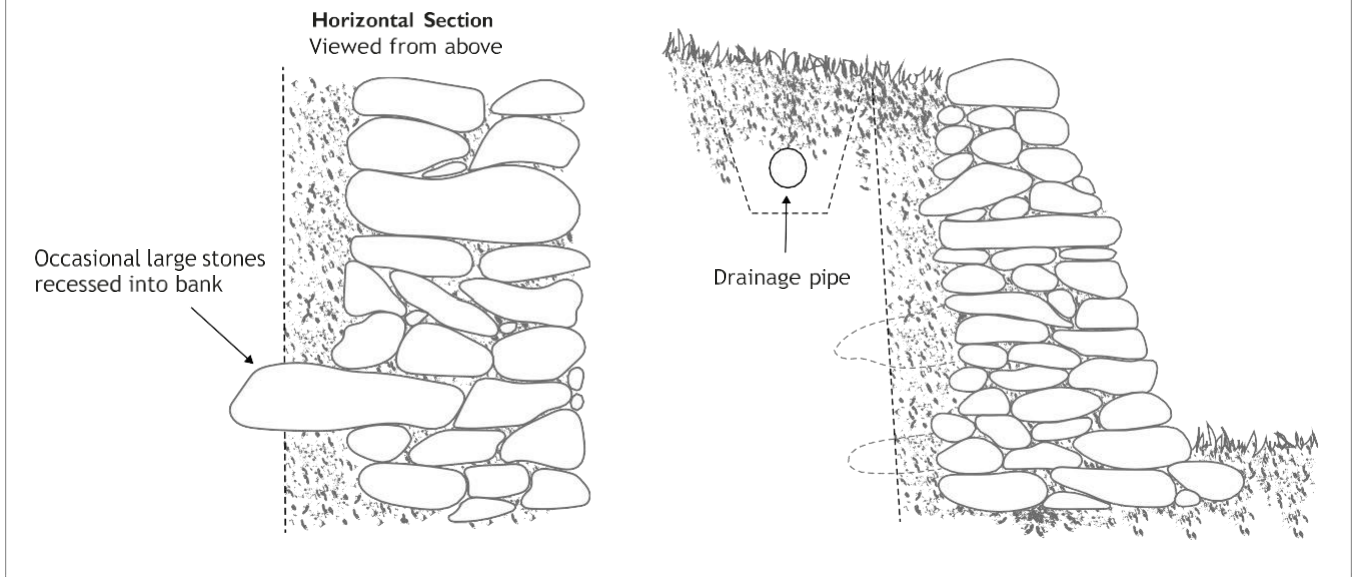

Slate Fence Restoration Item Code: L032

Payment Rate: £28.55 /m²

This technical note describes the minimum standard of work required in order to receive payments for 'Slate Fencing Restoration of Existing'. Any variation from the standards set out must be approved by the Welsh Government prior to starting the work.

Slate fences are a feature in the landscape in areas where the slate has been quarried commercially, notably at Nantlle, Waunfawr, Llanberis and Bethesda in North Wales.

You must adhere to the following:

- Restore existing slate fences only.
- Restore the fence so that there are at least three vertical slates per metre run.
- Set slates into the ground to a sufficient depth to ensure stability.
- Ensure that the top of the slates are at least 106cm from the ground.
- Wire individual slates together by drilling the slates and using at least 3 lines of wire (top, middle and bottom of the slate fence). Two wires should be used on each line and loops twisted around the slates, as shown in the diagram below. Where slates are spaced more widely, the individual slates should be drilled and the wire strained as in a standard post and wire fence using wooden straining posts.
- All slate used to restore slate fences must match the slates in existing features.

Requirements and guidance in addition to the specifications above:

- Where Ffermio Bro activities include the installation of access furniture such as stiles or gates on a Public Right of Way, it is your responsibility to ensure you obtain approval under Section 147 of the Highways Act, 1980, from the appropriate Highway Authority.
- Best practice is to set slates at least 60cm into the ground to ensure stability.

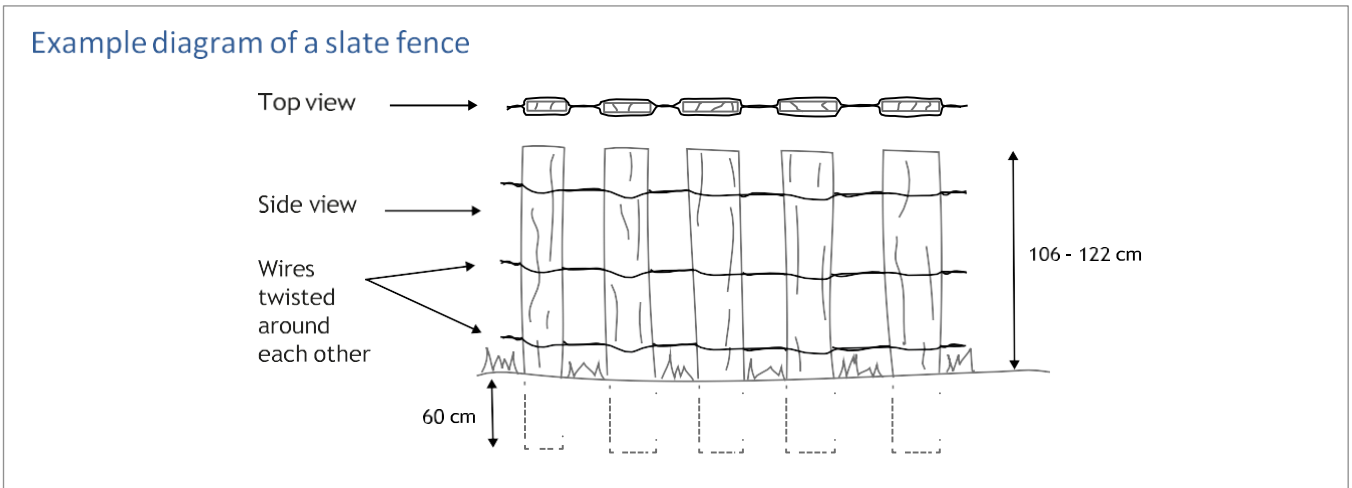

Top Wiring on Stone Walls

Item Code: L033

Payment Rate: £2.49/m

This technical note describes the minimum standard of work required in order to receive payments for 'Top Wiring on Stone Walls'.

Any variation from the standards set out must be approved by the Welsh Government prior to starting the work.

You must adhere to the following:

- Use fencing timber comprising either hardwood or pressure treated softwood.
- Ensure that timbers, wire and galvanised staples consist of new materials.
- Use posts with at least 6.5cm top diameter. Posts must be set at centres of 3m or less. Posts should be set within the wall.
- Attach at least one line of wire (4mm gauge plain or 2.5mm two ply barbed) to the posts with galvanised staples.
- Remove any existing derelict fencing.

Do not:

- Use trees and shrubs as strainers or fencing posts, or attach wire, staples or netting to them.

Requirements and guidance in addition to the specifications above:

- Where Ffermio Bro activities include the installation of access furniture such as stiles or gates on a Public Right of Way, it is your responsibility to ensure you obtain approval under Section 147 of the Highways Act, 1980, from the appropriate Highway Authority.

Fruit Trees Plus Guard and Stake

Item Code: L034

Payment Rate: £125 each

This technical note describes the minimum standard of work required in order to receive payments for planting 'Fruit Trees with a Guard and Stake'. Any variation must be approved by the Welsh Government.

In the past, nearly every farm would have grown varieties of fruit for domestic use and for marketing locally. As the trees aged, they were not replaced; the few surviving examples are a distinctive feature in the countryside and often have a high wildlife value.

The retention of old fruit trees should take priority over re-planting, as old trees are important for their biodiversity value and can be pruned to prolong their life.

You must adhere to the following:

- Use either M25 or MM111 rootstocks to give a traditional 'standard' size tree at maturity.
- Plant trees at a maximum density of 100 trees per hectare and space the trees throughout the area to be planted.
- Stake young trees and protect from grazing livestock by using a guard.
- All guards constructed from timber rails must be at least 1.2m high and set at least 1m from the tree to protect against sheep (or 1.5m to protect against cattle and horses). Each of the 4 corner posts should have a minimum diameter of 10cm x 10cm. At least 4 wooden rails with a minimum diameter of 10cm x 5cm should be fixed to the outside of the posts. Galvanised stock netting should then be fixed around the outside of the structure and held in place with galvanised staples.
- Triangular shaped enclosures are only acceptable where sheep are the sole livestock. Such enclosures must be at least 1.2m high and set at least 1m from the tree to protect against sheep. It is important to remember that as the tree grows it may be necessary to widen the guard.
- Use fencing timber comprising either hardwood or pressure treated softwood.
- Ensure that timbers, wire, netting and galvanised staples consist of new materials.

Do not:

- Use dwarfing rootstocks.

Requirements and guidance in addition to the specifications above:

- Plant a selection of trees including early and late flowering varieties, to assist with pollination and to reduce problems caused by frost or disease. The addition of a small number of plums, damsons or pears, as well as apple trees will add diversity.
- As a guide, trees should not be planted less than 6m apart.
- When constructing the guards, use a combination of vertical posts and horizontal rails to build a rigid structure. Fix wire netting around it to prevent access by livestock. The horizontal rails will prevent the posts from being loosened. A variety of stock might have access over time so the guard must be strong enough to withstand the worst case scenario. Do not try to increase the distance of the top rail from the tree by slanting the posts outwards. This will make it difficult to fix the netting securely in place.
- It is not necessary to top the enclosure with barbed wire, as this is unlikely to stop animals leaning over, and you will make it more difficult to get into the enclosure to tend the tree.
- Additional sets of rails may also be placed mid-way up the posts to provide additional strength.

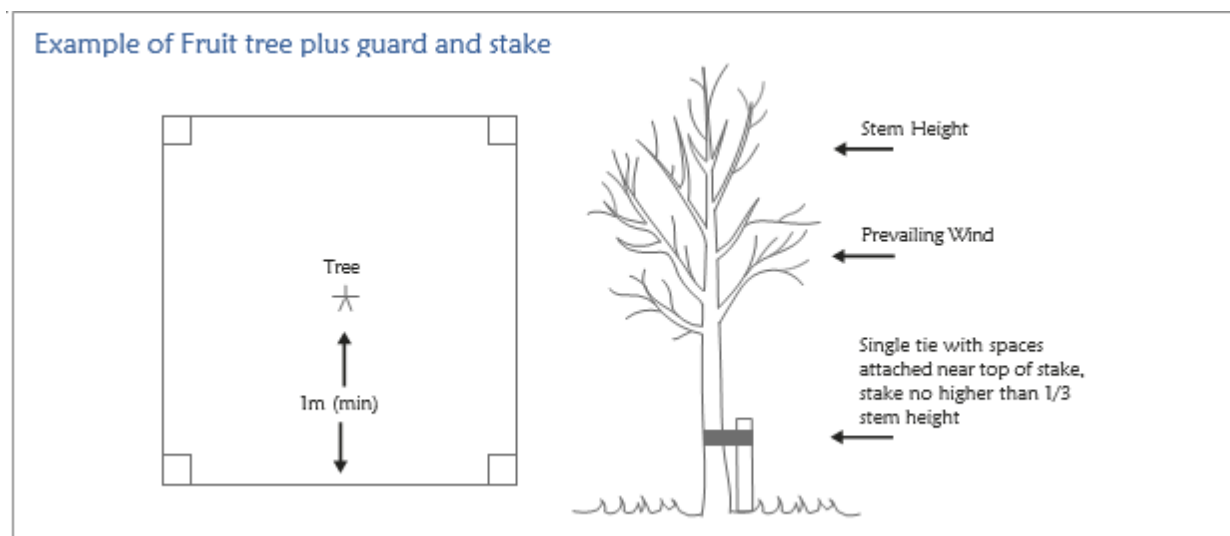

Maintenance of Gateways with Hardcore
Item Code: L035

Payment Rate: £9.36/m²

This technical note describes the minimum standard of work required in order to

receive payments for 'Maintenance of Gateways'. Any variation must be approved by the Welsh Government prior to starting the work.

What is the purpose of this activity?

Gateways and other areas which are frequently used by livestock and farm vehicles can be at increased risk of compaction and erosion. Compaction leads to poor drainage where water collects and pools.

Gateways can also act as exit points for run off from a field. Many streams and rivers in Wales are affected by pollution from agricultural runoff, which impacts on biodiversity, fisheries and drinking water quality. Installing hardcore in gateways will help reduce compaction, erosion and any resulting run off.

You must adhere to the following:

- Lay stone to a minimum depth of 200mm across the gateway and approach to create a flat even hardcore pad.
- Repair any damage or excessive wear such as that caused by harvesting or natural events to area of hardcore immediately.

Do not:

- Use concrete to set the stone in place.
- Use the hardcore pad as a location for feeders, drinking troughs or to store vehicles and machinery.

Requirements and guidance in addition to the specifications above:

- Ensure that you have the appropriate Flood Risk Activity Permit if you are planting or fencing near a main river, flood plain or flood defence structure. Alternatively, ensure you have the appropriate Ordinary Water Course Consent if you are carrying out works near an ordinary water course. What may be considered a ditch may be an ordinary watercourse, so consent may be required. As such, the permit/ consent (or confirmation that a permit/ consent is not needed) should be retained and made available on request. See General Rules for more details.

Post and Wire Fencing with Netting

Item Code L036

Payment rate £8.33/m²

This technical note describes the minimum standard of work required in order to receive payment for 'Post and Wire Fencing with Stock Netting'. Any variation must be approved by the Welsh Government prior to starting the work.

You must adhere to the following:

- Ensure that you have obtained, and adhere to any licences, consents or permissions that are needed.
- Use fencing timber comprising either hardwood or pressure treated softwood.
- Ensure that timbers, wire, netting and galvanised staples consist of new materials.

- Use straining posts that are a minimum of 12.5cm cross section and at least 2m long. Straining posts must be set into the ground at a sufficient depth to ensure stability. Straining posts must be placed at either end of the fence line and at centres of 100m or less, as well as at every horizontal or vertical change of direction.
- Attach struts at each end of the fence line and at all changes of slope and direction. Struts must have a top diameter of at least 6.5cm and must be supported to prevent them splaying outwards. Use intermediate posts that are at least 6.5cm diameter (round posts and sawn timber) and at least 1.7m long. Half round posts are acceptable provided they measure at least 6.5cm from the midpoint of the sawn side to the midpoint of the round side. Intermediate posts must be set at centres of 3m or less.
- Attach netting to posts with galvanised staples.
- Attach wire to posts with galvanised staples with the distance from the ground to the top wire no less than 1.05m. In cases where there is heavy pressure from sheep or cattle, a second line wire on top of the netting as well as an additional wire at the bottom should be added. The top wires of any fencing erected next to public access routes must consist of plain wire or an additional line of plain wire must be affixed to the outside of the posts closest to the route in question.
- Ensure that the new fencing conforms to British Standards 1722 and 4102, as amended.
- Use trees and shrubs as strainers or fencing posts, or attach wire, staples or netting to them.

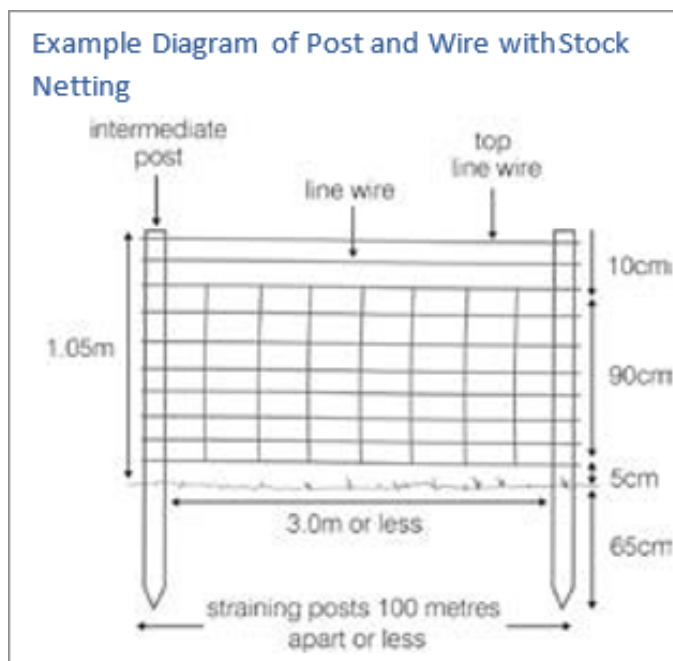

Requirements and guidance in addition to the specifications above:

- Best practice is to set the posts at least 1m into the ground to ensure stability.
- Diagonal struts must be supported with either a base plate or a suitably positioned intermediate post to prevent them splaying outwards.
- Ensure that you have the appropriate Flood Risk Activity Permit if you are planting or fencing near a main river, flood plain or flood defence structure. Alternatively, ensure you have the appropriate Ordinary Water Course Consent if

you are carrying out works near an ordinary water course. What may be considered a ditch may be an ordinary watercourse, so consent may be required. As such, the permit/consent (or confirmation that a permit/consent is not needed) should be retained and made available on request. See Terms and Conditions for more details.

- Where INRS activities include the installation of access furniture such as stiles or gates on a Public Right of Way, it is your responsibility to ensure you obtain approval under Section 147 of the Highways Act, 1980, from the appropriate Highway Authority

Supplement for Rabbit Fence Netting Item Code: L037

Payment Rate: £2.37/m

This option is supplementary and can only be used against the following options where they are also being installed:

- L009 – Post and Rail Fence**
- L010 – Post and Wire Fence**
- L013 – Parkland Tree Guard**

This technical note describes the minimum standard of work required in order to receive payments for ‘Supplement for Rabbit Fence Netting’. Any variation must be approved by the Welsh Government prior to starting the work.

Rabbit fencing can be specifically used to prevent damage to specific landscape features such as newly planted trees and hedgerows.

You must adhere to the following:

- Attach all wire and netting to posts with galvanised staples.
- Use galvanised wire netting at least 1.05m high, with a mesh no larger than 3cm.
- Ensure the top edge of the netting is at least 0.75m above ground level.
- Ensure that timbers, wire, netting and galvanised staples consist of new materials.
- Ensure that the netting is fastened to the fencing with the bottom edge of the netting buried in the ground to a sufficient depth to prevent rabbits burrowing underneath.
- Where required, fix strands of line wire to support the rabbit fence.
- Ensure any gates used in rabbit fences are appropriately proofed to prevent rabbit/hare access.
- Ensure that the new fence conforms to British Standards 1722 and 4102, as amended.

Do not:

- Use trees and shrubs as strainers or fencing posts, or attach wire, stables or netting to them.

Requirements and guidance in addition to the specifications above:

- Prevent rabbits burrowing underneath by ensuring that the netting is buried in the ground to a depth of 15cm and then turned outwards a further 15cm and anchored securely.
- Ensure that you have the appropriate Flood Risk Activity Permit if you are planting or fencing near a main river, flood plain or flood defence structure. Alternatively, ensure you have the appropriate Ordinary Water Course Consent if you are carrying out works near an ordinary water course. What may be considered a ditch may be an ordinary watercourse, so consent may be required. As such, the permit/ consent (or confirmation that a permit/ consent is not needed) should be retained and made available on request. See General Rules for more details.
- Where Ffermio Bro activities include the installation of access furniture such as stiles or gates on a Public Right of Way, it is your responsibility to ensure you obtain approval under Section 147 of the Highways Act, 1980, from the appropriate Highway Authority.

Example of Rabbit Fencing

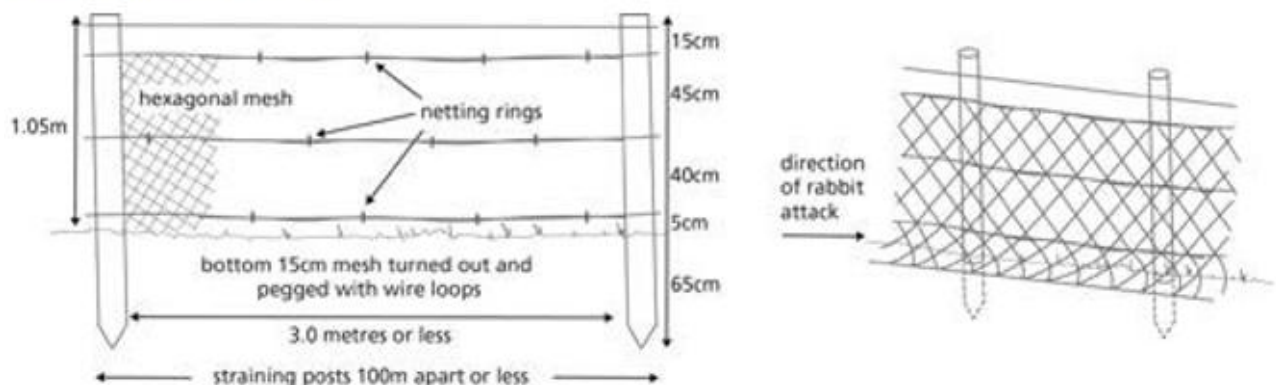

In-Ditch Wetland Item Code: L082

Payment Rate: £244.28 each

This technical note describes the minimum standard of work required in order to receive payments for 'In-ditch Wetland'. Any variation must be approved by the Welsh Government prior to starting the work.

In-ditch wetlands are ditches that have been widened to create a broader shallower wetland area. They are designed so vegetation slows the flow of water, to increase sediment deposition from field surface runoff, field drains, and ditches.

The purpose of an in-ditch wetland is to:

Improve water quality: In-ditch wetlands trap sediment carried in runoff from fields and farmland, which could otherwise pollute rivers and lakes downstream.

Reduce flooding: In-ditch wetlands slow the flow of water by providing valuable space where runoff can disperse, providing storage for floodwater which helps reduce flooding downstream.

Create a wildlife habitat: In-ditch wetlands provide additional positive benefits to the nature conservation (nesting habitat for wetland birds in particular reed buntings, reed, sedge and Cetti's warbler) and landscape value at the farm scale.

You must adhere to the following:

- Choose a location within existing man-made field ditches with a low gradient, where the land on either side is within your control. These are otherwise known as Stage 1 ditches which do not have continuous flow year round. The diagram below shows a typical ditch network.
- Widen the chosen area to a minimum of 10m in length and to a maximum of 3m wide and flatten the bed.
- Create a soil bund with a pipe at the lower end of the ditch to act as an outflow. The bund should be made wider than the ditch. The top should be level and at least 50cm above the intended water line. The bund should have slightly sloping sides.
- Insert one or two pipes within the bund to act as an outflow. The pipes should be between 8 –10” in diameter, and located 30cm (12”) below the top of the bund.
- Extend the pipe beyond the bund base on the downstream side of the bund to prevent the outflow eroding the bund.
- Plant up the bed with native sedge, rush or reed species, or with willow or Alder. For reed, rush and sedge species, plant at a density of 3 plants/m².

Do not:

- Locate in-ditch wetlands on natural watercourses.
- Damage other habitats such as reed beds to create in-ditch wetlands.
- Create this option between 1 March and 31 August.

Requirements and guidance in addition to the specifications above:

- Ensure that you have the appropriate Flood Risk Activity Permit if you are planting on fencing near a main river, flood plain or flood defence structure. Alternatively, ensure you have the appropriate Ordinary Water Course Consent if you are carrying out works near an ordinary watercourse. What may be considered a ditch may be an ordinary watercourse, so consent may be required. As such, **the permit/consent (or confirmation that a permit/consent is not needed) should be retained and made available on request.** See Terms and Conditions for more details.
- This option must not be used on natural watercourses, due to legislation requiring fish passage to be ensured at all times.

- Carry out this activity when ground conditions are as dry as possible between September and February. Temporarily bund the water flow into this area if needed, which will improve access for excavating and planting.
- Spread the excavated material thinly over the top of the banks so as to prevent weeds such as common nettle, creeping thistle etc., from dominating. Ensure the silt cannot run straight back into the in-ditch wetland.
- When constructing the bund, remove topsoil and scarify the subsoil to improve the seal between the dam and the ground surface. Build the bund slowly in layers 15cm thick and compact each layer in turn.
- Take care during completion of the activity to ensure no sediment laden water is allowed to enter the receiving watercourse.
- Do not plant with willow or alder if sedimentation is likely to be high.
- Plant up the bed with plant species already found in the local area. Do not collect protected plant species, or collect from a Site of Special Scientific Interest (SSSI). This is in line with Cross Compliance Regulations.
- For willow species plant at a density of 1 plant per m² and for alder species at 2m² spacing.
- Coppice willow and alder species every 3-5 years. Reed, rush and sedges plants should be cut every other year to prevent them from dominating the wetland. Cut in early spring before bird nesting to provide maximum roosting cover in the winter.
- This activity should be sited and managed to ensure no risk of flooding results.

In-ditch wetland (aerial view)

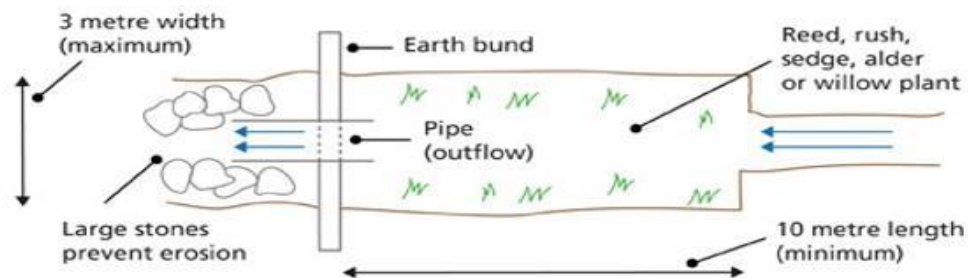

In-ditch wetland (x-sectional view of earth bund)

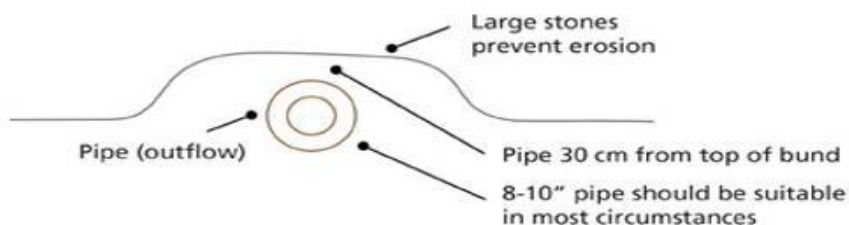

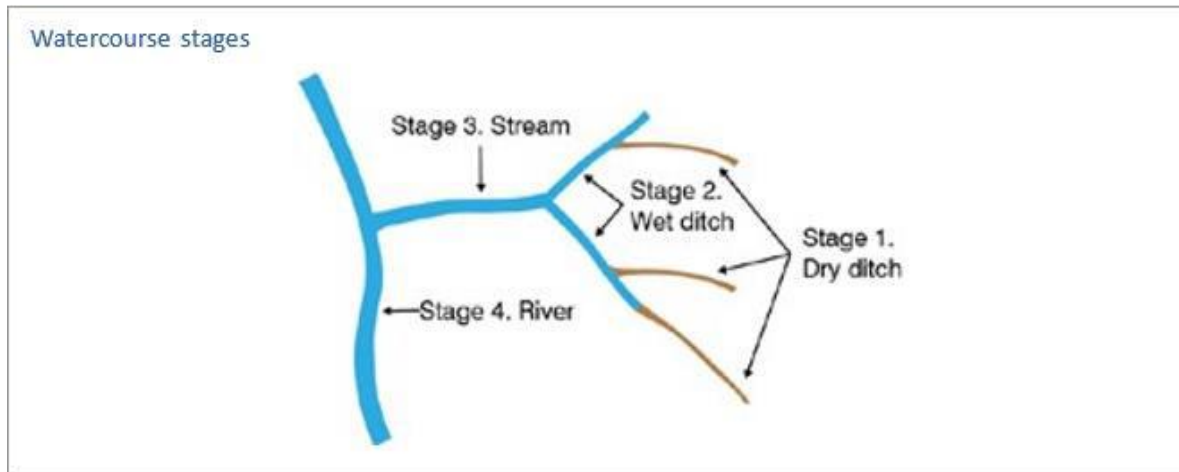

Soft Engineering of River Banks

Item Code: L083

Payment Rate: £ 115.96 /m

This technical note describes the minimum standard of work required in order to receive payments for 'Soft Engineering of River Banks'. Any variation must be approved by the Welsh Government prior to starting the work.

What is the purpose of this activity?

Riverbanks and the riparian zones immediately behind the bank top provide valuable wildlife habitat that can support a wide range of plant and animal species. They supply shelter, food and shade and protect the river from surface runoff. Riverside vegetation and the fibrous roots of that vegetation help to maintain the stability of the bank and prevent downstream flooding and further erosion by reducing the river's energy.

Naturally occurring erosion of riverbanks is an important river process that reduces the energy of river flows, redistributes sediment and provides nesting locations for birds such as sand martins and kingfishers. However, human activity can increase erosion. Livestock, for example, can destabilise banks through poaching and removing vegetation, while river engineering such as gravel removal, re-profiling and hard engineering works can increase the energy of the river and increase erosion.

Soft engineering (or bioengineering) measures utilise natural processes to reduce future negative erosion whilst allowing the area to re-vegetate and stabilise. Compared with traditional 'hard' defences (e.g. rock, concrete, gabions) woody materials create more diverse habitats for plants, invertebrates and fish. Soft engineering measures are more resilient in the long term as the materials used are flexible, so they absorb and dissipate the erosive forces rather than simply reflect energy as per hard defences. Furthermore, areas of soft engineering can be coppiced in the future to supply a ready and freely available source of materials for use on neighbouring sites.

River engineering is difficult and it is worth obtaining expert advice on the most appropriate techniques. Your local rivers trust, the River Restoration Centre ([river advice, consultation, projects, RRC | the River Restoration Centre](#)) or Natural Resources Wales may all be able to recommend the most appropriate approach, or supply further guidance.

You must adhere to the following:

- Install the correct quantity of river bank soft engineering on damaged or eroding watercourses, using sufficient stakes and withies to ensure a stable and robust structure. Guidelines for choosing and constructing the correct style of soft engineering are laid out below.

Do not:

- Graze the area of soft engineering.
- Use soft engineering as a retaining structure.
- Allow soft engineering to block water flow in small river channels.

Requirements and guidance in addition to the specifications above:

- Ensure that you have the appropriate Flood Risk Activity Permit if you are planting or fencing near a main river, flood plain or flood defence structure. Alternatively, ensure you have the appropriate Ordinary Water Course Consent if you are carrying out works near an ordinary water course. What may be considered a ditch may be an ordinary watercourse, so consent may be required. As such, **the permit/consent (or confirmation that a permit/consent is not needed) should be retained and made available on request.** See Terms and Conditions for more details.
- There are different bank protection techniques using live and dead woody material that may be suitable depending on the site. Select which of these techniques (or combination) is suitable for your site, and follow the guidance below.
 - Willow spiling is a traditional technique used to stabilise eroding banks. It involves weaving live willow rods (withies) between vertical live willow stakes set into the affected bank at regular intervals to create a living fence like structure, or 'revetment'. The space behind the willow fence to the existing bank is then filled with soil to provide an area for the willow roots to grow. There are 2 types of spiling – producing a tighter weave for revetments below water level, and a looser weave for revetments above water level.
 - Hurdles can be used instead of spiling where the nature of the site makes it dangerous or unsuitable to create spiling in situ.
 - Faggoting (brushwood or brashings tied in bundles) can be used by themselves or in conjunction with spiling or hurdles depending on the nature of the site. Faggots (or fascines) are bundles of willow or brushwood, bound together and used for various stabilisation and revetment purposes. Faggots slow the flow of moving water and trap silt and sediment, and the buried branches then help consolidate the sediments against renewed erosion. Do not use in locations where other habitat is present that could be harmed by increased willow cover e.g.

fens, wet unimproved grassland, wet heath, rhos pasture, bogs, or areas where you know ground nesting birds such as lapwing or curlew nest.

Spiling

1a: A tight weave spiling for revetments below water level.

- Installing revetments below water level may require specialist contractors.
- Use vertical stakes of 65-100mm (2.5-4") diameter for spilings up to 600mm high. For spilings up to 900mm (3') high, thicker stakes of 100-130mm (4-5") diameter will be needed.
- Use crack willow (*Salix fragilis*) or white willow (*Salix alba*) to produce the best material for stakes.
- Knock the stakes in vertically along the line of the revetment, about half a metre apart and so that two-thirds of the finished height of the stake is below soil level, then cut the tops to the finished height.

Example of tight weave spiling below water level

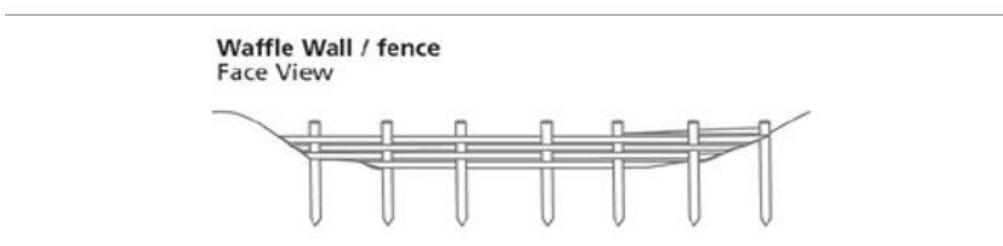
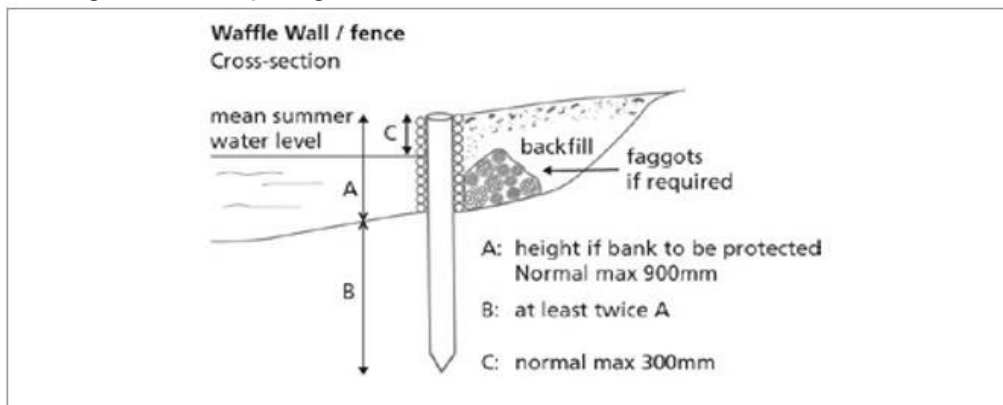

- Use withies which have a butt diameter of 10-20mm (0.25-0.75”) and be of a length equivalent to five times the stake spacing, to give a close, tight weave. Use osier (*Salix viminalis*), goat willow (*Salix caprea*) or grey willow (*Salix cinerea*) to produce the best material for withies. Weave the withies between the stakes, alternating the direction of the butt ends and tucking both ends in so they don't protrude.

At the end of each length of revetment, the spiling should be run into the bank so the last two to three stakes are completely buried after backfilling. Backfill to the required bank profile with soil once stakes and withies are securely placed. Place faggots (see below) behind spiling where there is a risk of backfill washing out. Undertake spiling between November and March (when average temperatures are below 2°C).

Use freshly cut willow for the vertical stakes and horizontal withies, so that they will sprout and produce a living revetment.

Pollarding or coppicing of bank side willow, or pruning of earlier sapling, will produce suitable material of the sizes mentioned above. Where willow is unavailable, alder can be used as an alternative. Willow or alder should be of local origin where possible. Stakes and withies can be stored between November and February for up to three weeks, provided they are kept cool and damp. Outside this season, they are best used within 48 hours of cutting and are always best having been soaked immediately before use. Where there is a risk of vandalism wire down the top withies and secure to the stake with a staple.

It is advisable to exclude stock for at least 2 or 3 years until the willow structures have established and the ground has become stabilised.

1b: A looser weave spiling for revetments above water level

- Insert the stakes as described for 1a above.
- Start weaving the withies between the second and third stake from one end. Push the end of the withy into the ground, and then weave between the stakes towards the end stake. Push the next withy into the ground and weave it alongside the first. The withies will root at the ends.
- Continue weaving along the stakes, until the withies reach the top of the stakes.
- Ensure the top withies are tightly woven to secure the spiling.
- Where there is a risk of vandalism wire along the top or down through the spiling.
- It is advisable to exclude stock for at least 2 or 3 years until the willow structures have established and the ground has become stabilised.

Example of tight weave spiling below water level

Looser weave Waffle Wall / fence

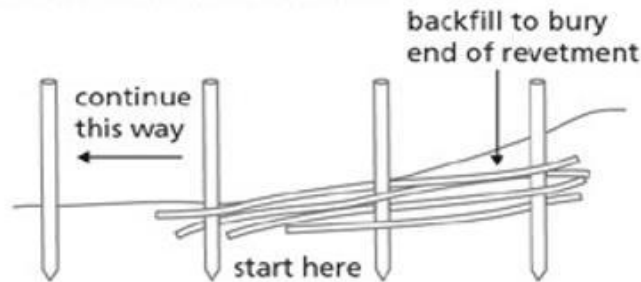

Hurdles

- Construct hurdles from hazel and willow.
- Construct hurdles to a maximum size that can be safely moved into position. Typically, a hurdle is 1.8m (6') long by 1m (3.5') high.
- Construct the hurdle from a series of upright 'zales' which should be at least 90cm tall, and no more than 25cm (10") apart, interwoven with tightly packed series of horizontal rods. A typical construction method is described below.
- Use two 1.5m (5') stakes for each hurdle, knock the stakes into position on the outer side of the revetment and wire the hurdles to the stakes to hold them in place.
- Backfill the hurdle with faggots and/or spoil.
- Construct hurdles off-site if working conditions at the bankside are difficult, however, ensure the hurdles are of a size and weight that you are able to transport. The structure should be strong enough to survive handling and positioning.
- If possible, use split hazel for the uprights or 'zales', as they hold the laterals better than round poles. Willow is also acceptable and is more suitable for the horizontal weaving.
- Push 900mm (3') 'zales' about 300mm (1') into the ground, evenly spaced in a straight line as shown.
- Weave hazel or willow rods between the 'zales', tucking each end back under itself to lock the wands in place. Force the wands down with your foot to give a tight weave. It may be necessary to wire or tie the top wands to discourage vandalism.
- Lift out the sections for transport to the site. Place the hurdles in position, overlapping as shown, below, and drive them in as far as the lower wands.

Waffle fence / hurdles

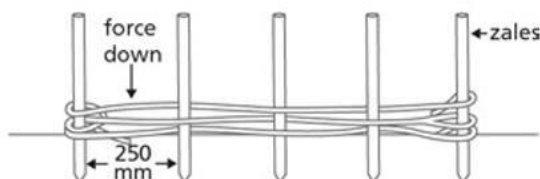

Faggots

- Construct faggots to a maximum size that can be safely moved by two people. Typically, the traditional size is about 2m (7') long and 300mm (1') diameter, bound at three points.
- Bind the faggots with twisted willow, baler twine or wire.
- Secure the positioned faggots by attaching them to stakes knocked well down into the bank.
Secure the faggot to the stake with wire. The faggots should be positioned as shown in the diagrams below, or placed behind hurdles, or spiling revetments. Consider using live willow cut in the winter as this is likely to root and grow. Growing willows are beneficial as their roots help to stabilise bank material and their shoots provide protection against bank scour.
- To stabilise a bank, the faggots can be laid in a single or double row, secured by stakes and wire as shown. As necessary, another layer can be added crosswise.
- Smaller faggots, of about 100mm diameter can be bound together to form 'mattresses', for laying on banks, subject to boat wash or strong flows. A large faggot at the base absorbs some of the wave energy.

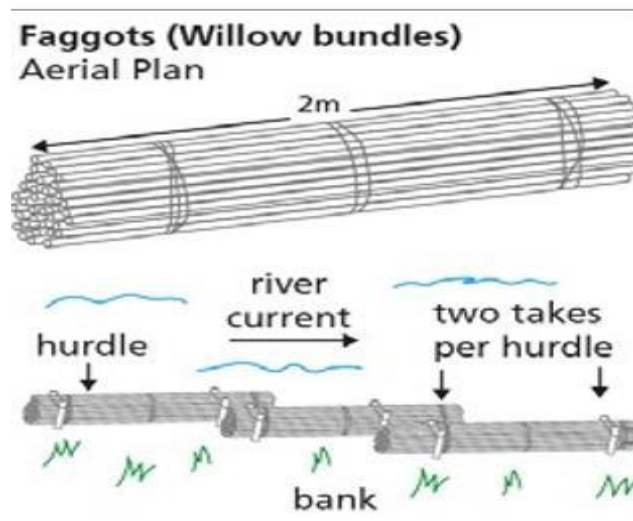

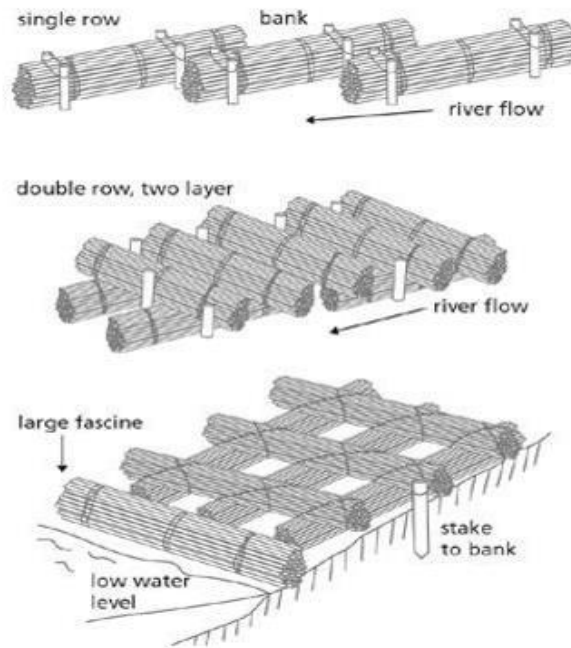

Pond Restoration Item Code: L084

Payment Rate: £ 7.88 /m

This technical note describes the minimum standard of work required in order to receive payments for 'Pond Restoration'. Any variation must be approved by the Welsh Government prior to starting the work.

Ponds and other small water bodies are important for freshwater biodiversity and storing water. Areas with large numbers of ponds can be particularly important because they provide habitats for a wider range of plants and animals.

Ponds are particularly vulnerable to nutrient enrichment, siltation and domination by invasive plants. Causes of this include nutrient-rich runoff from fields and farmyards, high stock densities causing overgrazing and poaching of margins, feeding of waterfowl and stocking with fish.

Invasive species may spread naturally or by deliberate or accidental introduction.

There are many different kinds of 'good' pond and you should not try to make all ponds on your farm look the same. A range of different sorts of ponds provide the widest range of habitats and can support some of our most threatened animals and plants.

If you have more than one pond, managing vegetation and silt on a staggered rotation of about 10 years will provide a range of different habitats.

Nevertheless, there are some general rules. Good ponds tend to have:

- Extensive areas of shallow water;
- Not too many fish or water birds;
- Clear water;
- A range of different water plants with no invasive species;
- Lightly grazed margins with no more than about half the pond shaded.

Ponds do not need to contain water all year, and some rare animals and plants need temporary ponds where predators cannot survive. However, water levels must be allowed to vary naturally, but the pond should contain water for at least 6 months per year.

Do not introduce animals or plants to your pond, especially from a garden pond, or a garden centre. Native pond species are good dispersers, and will arrive in healthy ponds by themselves.

The following types of pond are not suitable for this Ffermio Bro pond restoration option:

- A significant inflow or outflow 1m, or more, wide. This is because watercourses often carry silt and/or pollutants.
- Significant water quality problems that cannot be addressed by the restoration measures of this option. If there is serious pollution, disposal of material can be problematic and restoration is much less likely to be effective.
- Constructed wetlands or other traps for dirty water. These ponds are designed to trap pollution.
- Ponds with large numbers of fish or ducks make poor habitat for wildlife due to heavy predation.
- Ornamental ponds or ponds with non-native invasive species. These ponds make poor habitat for wildlife and restoration activities may encourage spread of invasive animals and plants.

You must adhere to the following:

Maintain a buffer strip of long vegetation between the pond and any upslope intensively managed land.

Ensure you have prevented any sources of pollution and nutrients from reaching the pond including any run offs that may contain fertilisers, slurries, manures, silage effluent or other nutrients.

Remove any scrap, redundant fencing or any other rubbish such as plastic wrap. Spread any removed silt on adjacent land in compliance with waste exemption U10 and waste exemption D1.

Exclude all stock from accessing the pond by ensuring there is at least 1 metre between the fence and water's edge. Stock access can be permitted to 10% of the pond area.

Create a mixed pattern of trees and shrubs around the pond by coppicing some scrub to allow more light onto the surface of the water and reducing leaf drop into the pond.

Do not:

- Restore ponds between March and August.
- Dredge more than one third of the surface area of a pond at any time. Allow dredged silt to run back into the pond. Dredged material must be spread down slope from the pond, but not where it may run into adjacent watercourses.
- Create islands in the pond.
- Allow stock drinking access for more than 10% of the pond.
- Remove any old trees from around the pond as they may contain bird nesting sites, bat roosts and rare mosses and lichens.

Requirements and guidance in addition to the specifications above:

- Ensure that you have the appropriate Flood Risk Activity Permit if you are planting or fencing near a main river, flood plain or flood defence structure. Alternatively, ensure you have the appropriate Ordinary Water Course Consent if you are carrying out works near an ordinary watercourse. What may be considered a ditch may be an ordinary watercourse, so consent may be required. As such, **the permit/consent (or confirmation that a permit/consent is not needed) should be retained and made available on request.** See Terms and Conditions for more details.
- Ensure that you apply for a European Protected Species licence from Natural Resources Wales (NRW) if you have Great Crested Newts in or close to the pond. This should not normally prevent restoration works since these will generally be beneficial to newts, but it is important to include sufficient time for the application process.
- This Ffermio Bro project includes dredging a maximum of one third of the pond. The remaining two thirds should be dredged in rotation in future years, but this is not included within this Ffermio Bro project. This ensures that invertebrate populations are not totally removed.
- Do not damage ponds that are considered existing habitat such as reed beds, fens or ponds on unenclosed land. It may be possible to obtain grants for pond restoration on existing habitat but this will require further discussion and/or consultation with Natural Resources Wales to ensure that no damage is being done to a Section 7 Habitat or Species, protected species or feature of a Protected Site.
- To minimise impacts on wildlife, restore ponds between September and January. Aim to do work in dry weather when pond levels are low and machinery will run less risk of poaching the soil.

Removing silt from the pond is appropriate when:

- No submerged aquatic plants can be seen, either because the water is very turbid or because the bed is clearly covered by a deep, loose layer of silt or leaf litter.
 - The sediment is completely black and smells of rotten eggs, and large bubbles of gas can be seen bubbling up occasionally.
-
- If removing from the pond, scrape out loose sediment until a firmer layer such as clay, marl or other firmer sediment is reached. Take care not to break the natural seal of the pond bed.
 - Do not create artificial islands as they encourage gulls and waterfowl, resulting in poor water quality.
 - If there is a danger of leaching from adjacent intensively managed fields, consider establishing a strip of long vegetation adjacent to the pond which can act as a buffer strip.
 - The Million Ponds website also has useful information regarding restoring ponds for other protected species such as Great Crested Newts and Water Vole: [PondNet eDNA surveys - Projects - Freshwater Habitats Trust](#)
 - More information on ghost ponds can be found at [Ghost Ponds : Resurrecting lost ponds and species to assist aquatic biodiversity conservation | Bringing lost ponds and their communities back to the land of the living.](#)

- More information on waste exemption U10 ([U10: spreading waste to benefit agricultural land - GOV.UK](#))
- More information on waste exemption ([U10: spreading waste to benefit agricultural land - GOV.UK](#)) D1 and registering waste exemptions.

Diagram – Cross Section of Pond

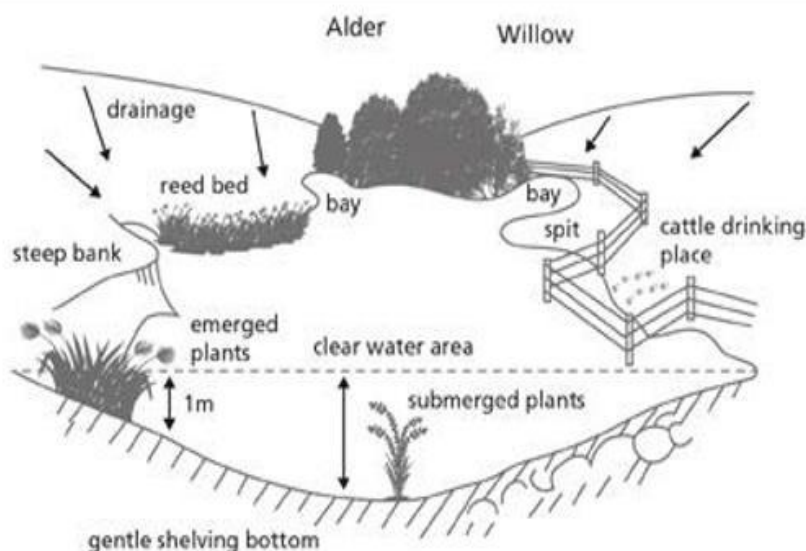

Bramble/Scrub Control – Hand-held or Knapsack Spraying Item Code: L085

Payment Rate: £0.029/m²

This technical note describes the minimum standard of work required in order to receive payments for control of 'Bramble/ Scrub Control – Hand-held or Knapsack Spraying'. Any variation must be approved by the Welsh Government prior to starting the work.

Bramble is a successful and invasive native species. It can produce dense thickets and can have a negative impact on other vegetation. Bramble will prevent new trees from establishing, so will have to be cleared before tree planting takes place. Before using pesticides (including herbicides) always consider whether control can be undertaken using non-chemical measures.

You must adhere to the following:

Treat a sufficient area of bramble to allow tree planting to be carried out and the trees to establish unhindered by bramble.

Ensure you use a product approved for hand-held or knapsack application on bramble/scrub. Product labels should be adhered to, retained and made available on request.

Anyone applying plant protection products (pesticides) as part of their work must hold a recognised specified training certificate. Users, or those who cause or permit use, must ensure that all reasonable precautions are taken to protect human health

and the environment, applications are confined to target areas and the amount used and frequency of use is as low as reasonably practicable.

Requirements and guidance in addition to the specifications above:

Do not:

Use a knapsack to control vegetation higher than waist height, or for clearing large areas. It will be tiring to keep the boom above the bracken and coverage will be impaired.

All manufactures label recommendations regarding herbicide application should be strictly adhered to.

More useful information may be found at the following locations: [Code of Practice for Using Plant Protection Products - HSE](#)

UKFS Guidelines: General Forest Practice [The UK Forestry Standard - GOV.UK](#)

Use of Herbicides

In all cases, the herbicide used must have a label recommendation for your intended use, and for the intended method of application.

Bracken Control (Mechanical Two Cuts/Year)

Item Code: L086

Payment Rate: £0.0059/m²

This technical note describes the minimum standard of work required in order to receive payments for 'Bracken control (Mechanical cutting)'. Any variation must be approved by the Welsh Government prior to starting the work.

Bracken is a vigorous perennial fern which grows from an underground rhizome system. Above ground, bracken fronds are fully open from about mid-June to August and it is at this time that the plants have deployed most of their nutrient reserves.

This option is available to clear areas of bracken so that ground flora can develop or to allow new trees and hedgerows to be established. This option is preferred where chemical control of bracken is not appropriate.

You must adhere to the following:

Control the bracken by bruising, crushing or cutting only.

Control bracken at least twice during the growing season. Additional guidance on the best time to control bracken is listed below.

Do not:

Control bracken using chemicals such as 'Asulam'.

Control bracken by burning.

Requirements and guidance in addition to the specifications above:

Crushing and cutting should be timed so that the fully extended frond is taken out before the plant has time to translocate food reserves from the frond back to the rhizome. The plant has expended considerable food reserves in producing the frond and well-timed removal causes substantial weakening. The period from May to mid-

August will generally be the best time to crush or cut depending on weather conditions.

This method is strongly recommended, especially where it is necessary to avoid chemical damage to water courses or sensitive plants such as other ferns.

Cutting should ideally be followed up by grazing of heavy stock such as cattle before tree planting, since this will help to prevent frond regrowth.

It is important to bear in mind that stands of bracken can contribute to landscape diversity and may well be of considerable value to wildlife in their own right. Where intermixed with scattered trees and shrub, bracken is often important for birds such as whinchat, yellowhammer and nightjar. Open bracken with an understorey of violets may support populations of fritillary butterflies. Even dense stands with heavy litter may provide cover for overwintering birds of prey such as hen harrier and short eared owl, as well as mammals such as bank vole, badger and deer.

Mixed Leys

Item Code: L087

Payment Rate: £341.00/ha

Establish a mixed ley, comprising minimum 5 grass species, 3 legume species and 3 herb species.

(Species not individual varieties within species)

Minimum seed rate 25 kg / ha.

Maximum Ryegrass (including ryegrass hybrids/cultivars) content 6 kg / ha

Maximum other grass seed content 9 kg / ha (Maximum total grass seed content 15 kg / ha)

Minimum requirements:

- Soil test carried out or undertaken in the 3 years prior to application. (Minimum requirement is to test for the P, K and pH levels). Action taken to rectify any immediate deficiencies identified in P, K and pH levels prior to establishment.
- Only use certified seed at the recommended seed rate.
- The choice and mix of species must be appropriate to the location.
- Minimum area of 1 ha. (You can split the minimum 1ha area across one or more land parcels, provided the area is at least 0.1ha).

Establishment:

- Do not plough or cultivate land before 1 March.
- Sow between 1 April and 31 August.

- Crop can be established through ploughing, traditional cultivations and drilling, minimum tillage or direct drilling.
- Mix the seed in the hopper immediately before sowing a seed mix to stop an uneven spread of crops.
- Seed can be broadcast or drilled, but no deeper than 1cm.
- Roll after sowing to retain moisture.
- If using minimum tillage or direct drilling, the use of an appropriate, approved herbicide to spray off an existing grass sward is required. (This requirement not applicable for farmers certified as organic).
- Once established, do not use pesticides, except herbicides to spot treat or weed-wipe injurious weeds* or invasive non-native species, soft and hard rush, nettles or bracken.
- Do not use inorganic fertilisers containing nitrogen following establishment until the following spring. (It is recommended that nitrogen fertiliser use is avoided to achieve maximum agronomic and environmental benefits from the diverse ley.)
- Maintain a 1m grass buffer strip adjacent to a hedge, earth bank or watercourse.

Management:

- Established sward to be managed to maintain sward diversity, to encourage the flowering and seeding of the mixed ley and to avoid poaching.
- A record of all field activity, including sowing date, evidence of fertiliser and pesticide applications, closed period and grazing or cutting dates should be kept for inspection.

Standard Item Review

Key requirements

All items to be purchased within 180 days of the grant award being offered.
Ensure all items purchased are on the premises at the time you submit your claim.
The project would not proceed without grant assistance.

Applications must also demonstrate that the following have been addressed.

- all other consents, licences and permissions have been granted where required
- compliance with minimum standards and legislative requirements regarding the environment, hygiene, animal welfare and all relevant health and safety standards

Conditions

- The award is made on the basis of statements and declarations made by you or your representatives in the application form and the claim form and any subsequent correspondence. The making of false or misleading statements is an offence.
- You must have bought the equipment and contacted RPW via RPW Online by the claim deadline within the grant award offer. If you have not contacted RPW within that time, the grant offer will be automatically rejected.
- Welsh Government may need to update the rules and conditions to take account of changes made to the Government of Wales Act 2006.
- You agree to abide by any changes following notification by Welsh Ministers.
- You agree to comply with all applicable domestic, or international laws or regulations or official directives.
- No alterations may be made to the project, including the location of the activity, without the written approval of Welsh Government.
- Equipment purchased with grant aid may not be disposed of, transferred or sold during the project and for five years from the contract end date only with prior written consent of Welsh Government. The grant awarded must be repaid in full.
- The applicant is required to read and understand the relevant scheme rules and guidance notes.
- You have given details that are true, accurate and complete to the best of your knowledge and belief on the applications and any supporting documentation.
- You acknowledge that neither Welsh Government nor any adviser appointed by Welsh Government shall be responsible for any advice given, including without limit any advice given in relation to the applications and that you are solely responsible for all business decisions undertaken.
- The applicant is required to comply with the rules on eligible costs as detailed in the scheme guidance notes.
- Projects should be completed within the timetable agreed with Welsh Government. You should not deviate from this without prior written agreement from Welsh Government.
- Claims must be submitted via the RPW Online grants claim application and be supported by all supporting documents as required by the scheme.

- Claims must be submitted in accordance with the timetable set out in the grant award letter. You must not deviate from the agreed timing and value of your claims without prior written agreement from Welsh Government.
- Grant can only be paid on expenditure that has been defrayed, that is, on payments that have cleared from a bank account.
- You undertake to meet any obligations in relation to obtaining planning permission, where necessary.
- You must confirm that none of the items covered by the application are replacements under an insurance claim.
- You must provide confirmation that no other public funding has been sought. If it is found that you have received public funding from another source your claim may be rejected, payments may be recovered and penalties may be applied.
- Records concerning the application and claim for this grant, including all original invoices and any other related documents, must be retained for at least five years after the project end date.
- You must undertake to meet any statutory obligations such as health and safety; employment; hygiene; environmental management and protection; animal or crop health and welfare that apply during the time of this project.
- You must allow representatives of Welsh Government, the Auditor General for Wales or their representatives to access and inspect land and any relevant equipment. On request, you must provide them with information and / or access to original documentation in relation to the project.
- The information provided in the application and any supporting documentation is subject to the requirements of Welsh Government's Code of Practice on Public Access to Information, the Freedom of Information Act 2000 and the Environmental Information Regulations 2004.
- You should be aware that, if successful, Welsh Government reserve the right to publish the name of your business or company, the amount of grant you were awarded and a summary of your project.
- The information provided in the application is subject to the Privacy Notice. The Privacy Notice explains Welsh Government's processing and use of your personal data and your rights under the General Data Protection Regulation (GDPR).