

Integrated Natural Resources Scheme: project delivery plan: technical specifications

Contents

Ladder Stile	4
Timber Bridle Gate and Posts.....	5
Timber Kissing Gate and Posts.....	6
Wooden Stiles.....	8
Badger Gate.....	9
Piped Water Supply.....	10
Water Gate	11
Water Troughs.....	13
Post and Rail Fencing	14
Post and Wire Fencing.....	16
Timber Field Gates (Hardwood)	17
Timber Field Gates (Softwood).....	18
Parkland Tree Stock Guards	19
Tree Shelter (60cm With Stake).....	22
Trees Standards	23
Trees Standards (no fencing)	26
Trees and Shrubs (Transplants).....	29
Trees and Shrubs - Whips	32
Sabre Planting.....	35
Spiral Rabbit Guards	37
New Hedge Planting.....	38
Hedge Coppicing and Gapping Up	39
Hedge Laying	42
Cross Drains.....	43
Kerbing	45
Sleeping Policemen	47
Rainwater Goods (Guttering)	48
Rainwater Goods – Downpipe.....	49
In-Ditch Wetland.....	50
Soft Engineering of River Banks.....	52
Pond Restoration	58
New Hedge Planting for Pollinators.....	61
Earth Bank Restoration.....	63
Stone-Faced Earth Bank Restoration	65
Slate Fence Restoration	67

Top Wiring on Stone Walls	68
Fruit Trees Plus Guard and Stake	69
Maintenance of Gateways with Hardcore	71
Post and Wire Fencing with Netting.....	72
Supplement for Rabbit Fence Netting	73
Borehole.....	75
Water harvesting and filtering equipment (Above ground)	75
Water harvesting and filtering equipment (Below ground)	76
Cover or floating cover for slurry stores (per square metre)	76
Deer Fencing.....	77
Re-Stocking	78
Basic Re-stock > 20ha > 350m.....	82
Basic Re-stock > 20ha >< 250 and 350m.....	83
Basic Re-stock <5ha < 250m	83
Re-Stocking: Native Broadleaved Trees	84
Re-Stocking: Broadleaved Trees.....	84
Bramble/Scrub Control - Hand Knapsack Spraying.....	85
Scrub Clearance (Mechanical).....	86
Invasive Plant Species Control.....	87
Rhododendron Control.....	89
Mixed leys (Also referred to as multi species or herbal leys)	91
Cover Crops.....	93
Post and Wire Fencing with Stock Netting	94

Version: 1

Issue Date: April 2026

Issued By: Welsh Government

© Crown Copyright 2024 ISBN Number: 978-1-83715-013-7

Ladder Stile

Item Code: D012

Payment Rate: £259.45

This technical note describes the minimum standard of work required in order to receive payments for 'Ladder Stile'. Any variation must be approved by the Welsh Government prior to starting the work.

Ladder stiles are used to allow walkers to cross walls and banks.

You must adhere to the following:

- Construct the ladder stile from pressure treated softwood or hardwood.
- Use timber with dimensions no less than those shown in the diagram. The steps can either be rebated into the 'A' frames or supported by extra pieces of timber. Secure the stile on both sides by burying the ends of the 'A' frame to a sufficient depth in the ground and anchoring them with stobs as shown.
- Construct a platform at the top of the stile to cross over wide walls or banks if needed.
- Ensure the gate is compliant with BS5709:2006, as amended. The least restrictive furniture must be used as possible, e.g. a gate is less restrictive than a stile.

Do not:

- Use ladder stiles on a Public Right of Way (PROW) unless approved by the Welsh Government.
- Use concrete to secure timber supports in the ground.
- Reduce the size of wide walls or banks to enable the ladder to span the boundary. Construct a platform at the top of the stile if needed.

Requirements and guidance in addition to the specifications above:

- Best practice is to bury the ends of the 'A' frame at least 30cm into the ground to anchor the stile.

Example of a step ladder stile

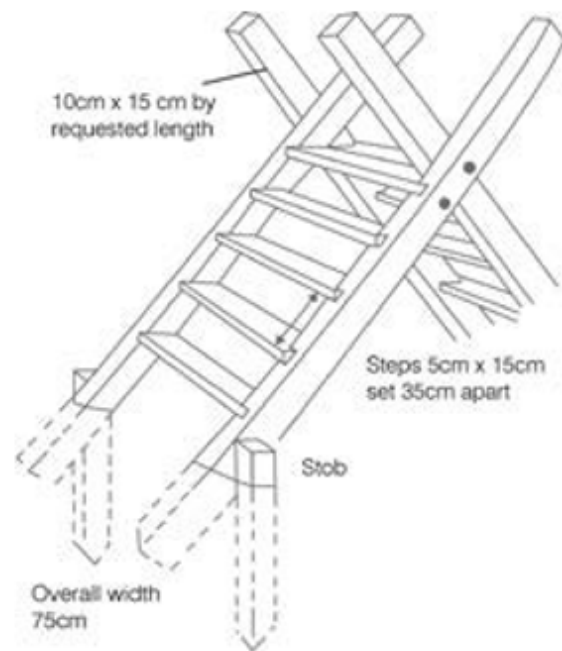

Timber Bridle Gate and Posts

Item Code: D013

Payment Rate: £301.39

This technical note describes the minimum standard of work required in order to receive payments for 'Timber Bridle Gate and Posts'. Any variation must be approved by the Welsh Government prior to starting the work.

Bridle gates are used to allow access for walkers and horse riders.

You must adhere to the following:

- Install Timber Bridle Gates and Posts constructed from either pressure treated softwood or hardwood.
- Install gates that are at least 1.5m wide and 1.3m high. Ensure there is sufficient space on one side of the gate for the horse to stand while the gate is being opened.
- Use a ready-made gate, or construct a gate. All gate timbers must meet the following dimensions:
 - Uprights should be at least 10cm x 7.5cm in cross section.
 - All rails should be 7.5cm x 2.5cm in cross section except the top rail which should be 10cm x 7.5cm.
- Hang the gate so that it can be opened from both directions.
- Fit latches that allow the gate to be opened without the rider dismounting.
- Ensure that all post timbers must meet the following dimensions;
 - Hanging posts must be at least 15cm diameter
 - Shutting posts must be at least 12cm in diameter
 - Posts must be set into the ground to a sufficient depth to ensure stability.

Do not:

- Install bridle gates and posts on Public Rights of Way (PRoW) unless approved by the Welsh Government.
- Use concrete to secure posts in the ground, as it can lead to rotting of the posts at ground level.

Requirements and guidance in addition to the specifications above:

- Use an 'extended' or a 'drop over' latch to allow the gate to be opened without the rider dismounting.
- In areas prone to vandalism, the top hook can be reversed to prevent the gate being lifted off.
- Best practice is to set the posts at least 70cm into the ground to ensure stability.

Example of a timber bridle gate

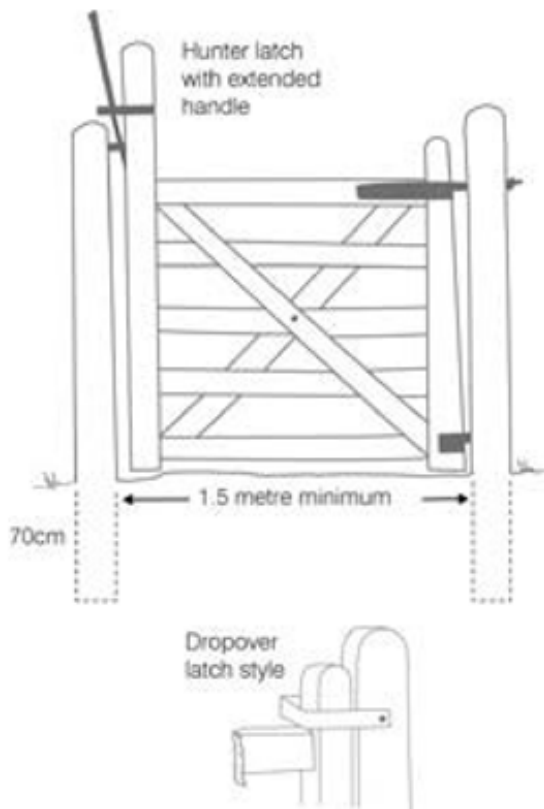

Timber Kissing Gate and Posts

Item Code: D014

Payment Rate: £362.00

This technical note describes the minimum standard of work required in order to receive payments for 'Timber Kissing Gate and Posts'. Any variation must be approved by the Welsh Government prior to starting the work.

Kissing gates are used to allow walkers to cross field boundaries.

You must adhere to the following:

- Install Timber Kissing Gates and Posts constructed from either pressure treated softwood or hardwood.
- Install a kissing gate that is stock-proof with the gate in any position, yet allowing free passage for pedestrians.
- Ensure that the kissing gate is an effective barrier against motorcycles and horses.
- Use a ready-made gate, or construct a gate. All gates must meet the following dimensions;
 - The gate must be 1.2m wide and 1.2m high.
 - A 1m cylinder, must be able to pass through. Note that the ‘throat’ dimension (the narrowest space to pass through when the gate is opened) must be at least 1m.
- Ensure that post and rails meet the following dimensions;
 - Uprights should be at least 10cm x 7.5cm in cross section.
 - Rails should be 7.5cm x 2.5cm in cross section except the top rail which should be 10cm x 7.5cm.
 - Hanging posts must be at least 15cm diameter.
 - Shutting posts must be at least 12cm in diameter.
 - Posts must be set into the ground to a sufficient depth to ensure stability.
- Hang the gate so that the gate hooks are ‘offset’ by 3cm. This will cause the gate to close against one of the side posts when released.
- Ensure the gate is compliant with BS5709:2006, as amended. The least restrictive furniture must be used as possible e.g. a gate is less restrictive than a stile.

Do not:

- Use concrete to secure posts in the ground, as it can lead to rotting of the posts at ground level.
- Use any barbed wire on the kissing gate.

Requirements and guidance in addition to the specifications above:

- For added protection against stock, a self-closing latch can be fitted.
- In areas prone to vandalism, the top hook can be reversed to prevent the gate being lifted off.
- Best practice is to set the posts at least 70cm into the ground to ensure stability.

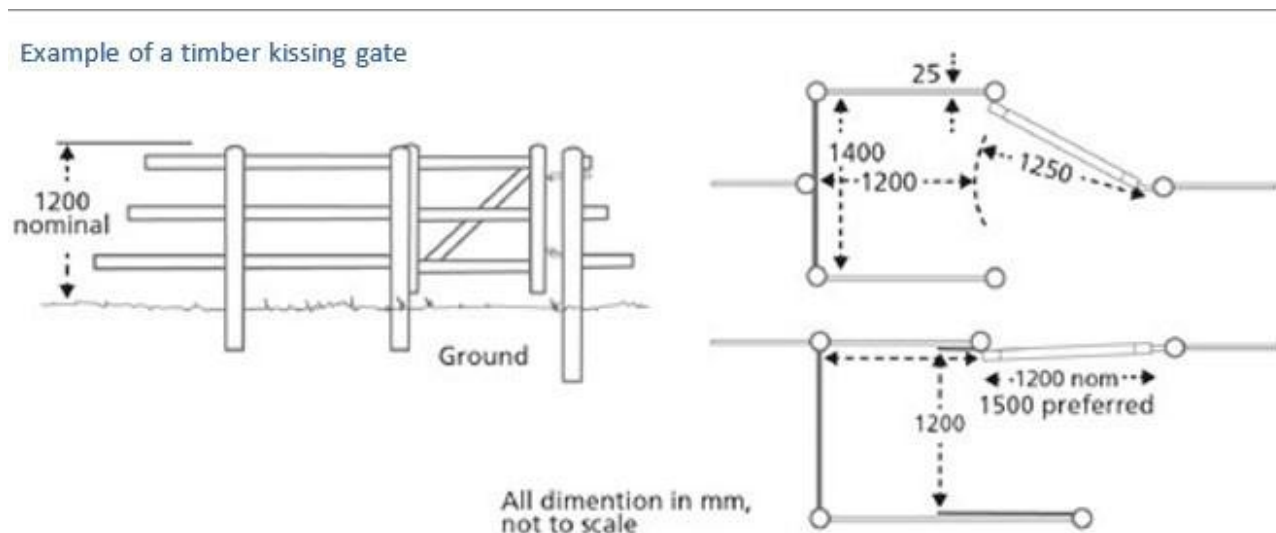

Wooden Stiles

Item Code: D015

Payment Rate: £125.01

This technical note describes the minimum standard of work required in order to receive payments for 'Wooden Stiles'. Any variation must be approved by the Welsh Government prior to starting the work.

Wooden stiles are used to allow walkers to cross field boundaries.

You must adhere to the following:

- Install wooden stiles constructed from either pressure treated softwood or hardwood.
- Use a ready-made stile kit, or construct a stile. For both narrow and wide stiles, they must meet the following dimensions;
- Step width should be 200mm
- Hand posts should be 70 to 100mm diameter or across faces
- Posts should be vertical to 1 in 30
- Steps should level in all directions to 1 in 30.
- Install a third step on the downhill side on a steep slope if needed. This step must be twice the width of a standard step and the 300mm step height rule applies.
- Ensure the stile is compliant with BS5709:2006, as amended. The least restrictive furniture must be used as possible e.g. a gate is less restrictive than a stile.

Do not:

- Allow the step tread boards to touch the cross-rails of the stile as a see-saw effect may develop, making the stile unsafe to use.
- Use posts as straining posts for fencing.

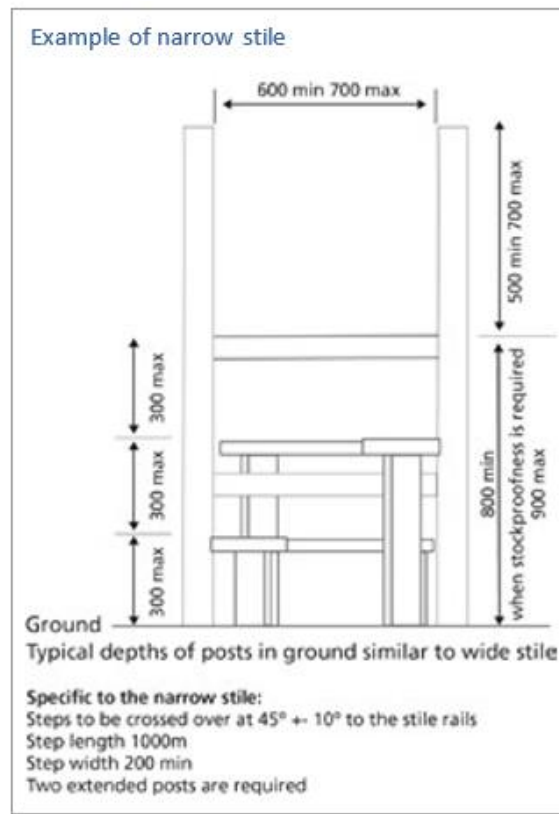
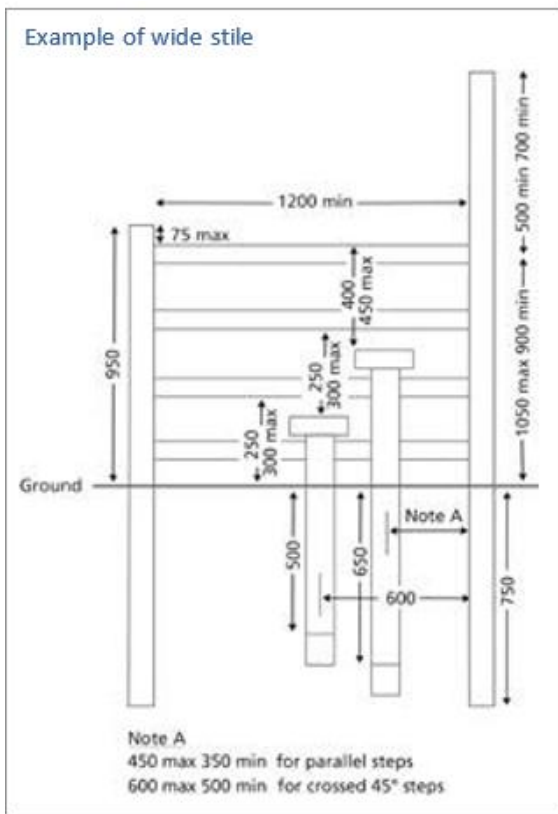

Badger Gate

Item Code: D016

Payment Rate: £41.10

This technical note describes the minimum standard of work required in order to receive payments for 'Badger Gates'. Any variation must be approved by the Welsh Government prior to starting the work.

Badgers normally follow the same route when moving around their territory. Fencing to manage an area of habitat should take into account established badger runs. Badger gates can be used to allow badgers to cross stock proof boundaries without damaging the fences.

You must adhere to the following:

- Install a badger gate using the same dimensions as shown in the diagram below.
- Gates must be located directly on existing badger runs in order to encourage the use of the gate by badgers.
- Bury the fence on either side of the gate to a sufficient depth into the ground to prevent badgers burrowing around the gate.
- Position a wooden or stone base under the gate to prevent erosion of the ground.

Requirements and guidance in addition to the specifications above:

- Best practice is to bury the fence to a depth of at least 15cm either side of the gate.
- Treat all timbers with a non-toxic, odourless preservative.

Example of a badger gate

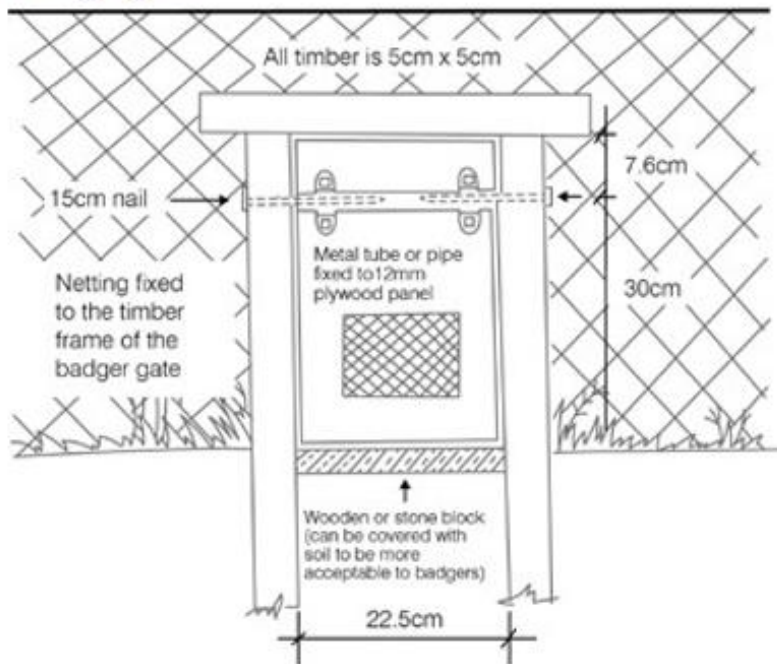

Piped Water Supply

Item Code: D017

Payment Rate: £1.39

This technical note describes the minimum standard of work required in order to receive payments for 'Piped Water Supply'. Any variation must be approved by the Welsh Government prior to starting the work.

Piping can be used to supply drinking water to water troughs where stock have been prevented from accessing other water sources by INRS activities.

You must adhere to the following:

- Install piping made from medium density blue polyethylene with a minimum external diameter of 2.5 cm.
- Use watertight joints made of brass or plastic.
- Bury pipework to a sufficient depth to prevent damage from surface activities.
- Reinststate disturbed ground to match the surrounding ground once pipework has been completed.
- Protect any pipework above ground from animal or frost damage.
- Ensure any pipes crossing open ditches or tracks are suitably protected. The pipe must be covered by a tubular steel guard or sleeve pipe, laid sufficiently below the ditch to allow space for ditch cleaning. When crossing farm tracks, ensure the pipe is sufficiently protected below the track.

- Control water supply at the point of supply and at each trough by isolating valves/stop cocks. The isolating valves/stop cocks must be protected against frost and damage from stock, and must be easily accessible.
- Where valve/stop cocks are buried, this must be at a minimum of 60cm and access should be available through a covered inspection chamber.
- Ensure that the water is able to supply sufficient cold potable water to continuously refill all the water troughs along its length throughout the year within 10 minutes.
- Ensure all water supply works are compliant with British Standards Codes of Practice BS 6572, as amended.

Do not:

- Damage other services such as water supply, waste, gas, electricity or telephone.

Requirements and guidance in addition to the specifications above:

- Consider combining access to valve positions with field drains to make inspection access easier.
- Consider a range of factors when determining pipe diameter. These include: water pressure, water capacity, variable flow, length of pipe, changes in altitude, volume of water required, number of troughs, number and type of stock using each trough.
- Where joints are buried underground, it is advisable to mark their locations, on fence posts for example, to assist with future maintenance.
- Bury pipework to a minimum depth of 60cm although this may need to be deeper if future deep ploughing or sub-soiling is envisaged.
- Lay pipes by trenching, mole plough or sub-soiler, depending on soil type and machinery available.
- Best practice when laying pipes under a ditch is that it is laid 60cm below the ditch to allow space for ditch cleaning.
- Best practice when laying pipes under farm tracks is to lay the pipe on a 7.5cm bed of sand and then covered by a further 10cm of sand before being overlaid by backfill.

Water Gate

Item Code: D018

Payment Rate: £337.81

This technical note describes the minimum standard of work required in order to receive payments for 'Water Gate'. Any variation must be approved by the Welsh Government prior to starting the work.

Water gates are required to control stock where fence lines cross rivers and streams. They are especially useful where the water level varies considerably throughout the year.

You must adhere to the following:

- Construct a gate comprising a series of wooden droppers attached to a length of cable or a round wooden rail which is suspended horizontally between straining posts. Each gate has to be constructed to fit the profile of the individual stream.
- Ensure the water gate is separated from the main fence line by short lengths of wooden rail or netting, fixed to straining posts that have been suitably positioned.
- Attach droppers that are at least 5cm square in cross section. Droppers must be constructed from sawn untreated timbers. The droppers must be drilled and threaded onto the cable of fencing wire with 15cm lengths of plastic pipe acting as spacers. As a result, each dropper is 15cm apart.
- Increase the dimensions of the droppers to at least 7cm square, where the stream gully is over 1.5m deep. Hang droppers on a round wooden pole using loops of fencing wire.

Requirements and guidance in addition to the specifications above:

- Suitable crossing points will have a hard river bottom and reasonable access from both banks. The correct choice of crossing points will make both construction and maintenance easier.
- Hanging the gate separately from the main fence allows the gate to be pulled off during heavy floods without damaging the main fence. Minimum damage will be caused to the gate which can then be recovered, repaired and repositioned.
- It is advisable to create larger water gates in several sections which will reduce the risk of the whole gate being lost or damaged during severe floods.
- It is advisable to periodically clear the base of the water gate, as the accumulation of debris at the base of the water gate will put pressure on both wires and stakes and can result in damage.
- Hang water gates at an angle, with the bottom of the gate resting on the streambed on the downstream side. This prevents stock passing underneath when the water level drops.

Examples of water gates

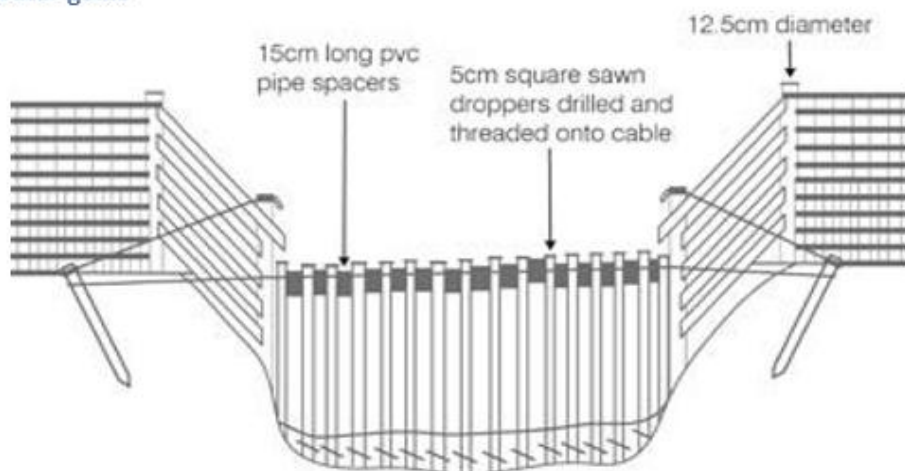

Examples of water gates

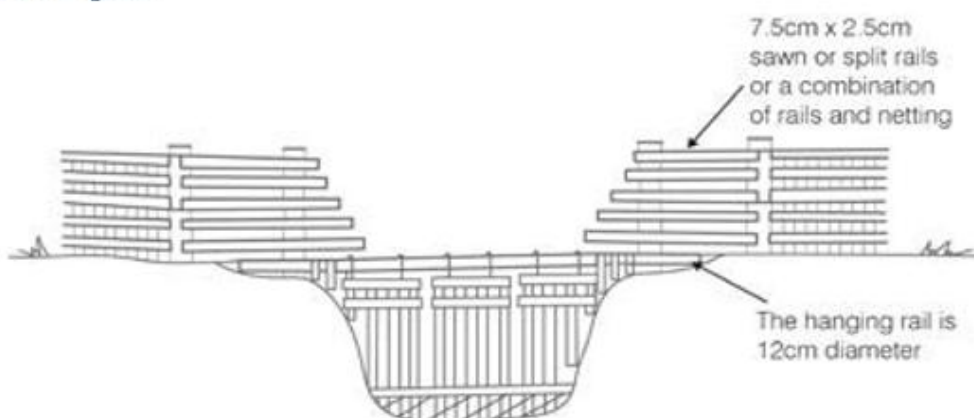

Water Troughs

Item Code: D019

Payment Rate: £224.00

This technical note describes the minimum standard of work required in order to receive payments for 'Water Troughs'. Any variation must be approved by the Welsh Government prior to starting the work.

Water troughs can be used to supply drinking water to livestock where they have been prevented from accessing other water sources by INRS activities.

You must adhere to the following:

- Use water troughs made of galvanised steel, plastic or concrete.

- Install a trough at least 1.8m length. They must either be connected to a water supply or supplied from a bowser on a regular basis, in order to provide sufficient potable water. The standard payment includes the cost of fittings such as ball cocks etc.
- Use water troughs that have been specifically designed for the purpose.
- Install the trough so that it does not spill or leak water – the payment rate includes an allowance for base supports.
- Ensure that water troughs conform to current British Standard Codes of Practice.

Do not:

- Locate water troughs in gateways or near footpaths.
- Locate water troughs in wet ground due to the risk of poaching.

Requirements and guidance in addition to the specifications above:

- Do not locate water troughs in known areas of botanical or wildlife interest.
- Aim to cause least landscape impact by locating the trough at the edge of fields and choose a material that has the minimum impact when viewed as part of the surrounding landscape.
- Install troughs of sufficient size to supply the type and number of stock in the field with their water requirements.

Example of a water trough

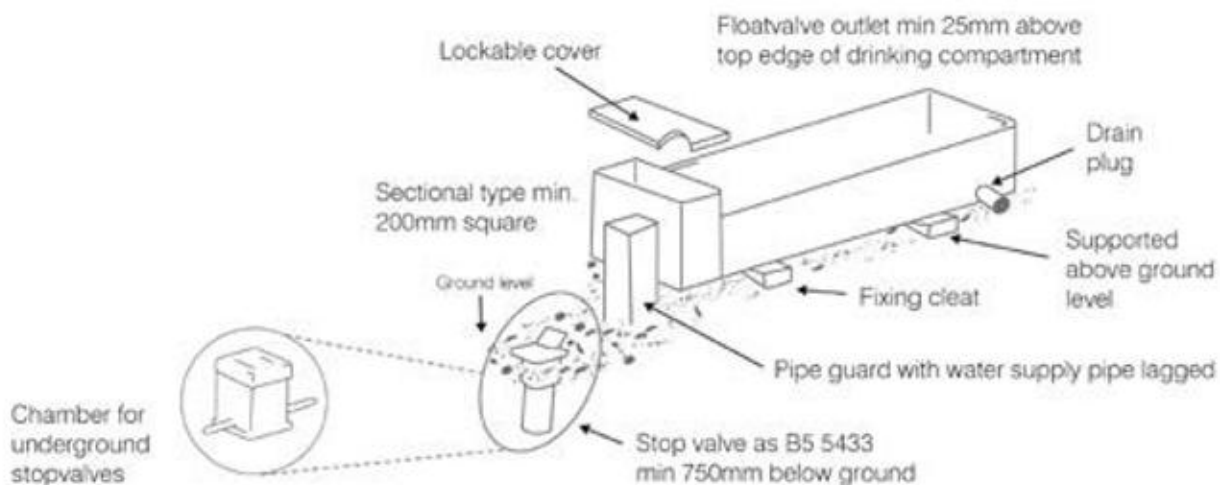

Post and Rail Fencing

Item Code: D020

Payment Rate: £12.54

This technical note describes the minimum standard of work required in order to receive payments for ‘Post and Rail Fencing’.

Any variation must be approved by the Welsh Government prior to starting the work.

Post and rail fencing is generally used where appropriate in the landscape, normally in parkland areas or for stock control along waterside features.

You must adhere to the following:

- Use fencing timber comprising either hardwood or pressure treated softwood.
- Use posts that are at least 1.8m in length, and no less than 12.5cm x 7.5cm cross section.
- Use posts that are square or rectangular.
- Install posts at centres not exceeding 2m (normally 1.8m as the standard length of rails is 3.6m).
- Set posts at a sufficient depth into the ground to ensure stability. The face of the post must be square to the fence line. If the tops of the posts are sawn after setting, the cut surfaces must be treated with a suitable preserving fluid of the same colour as the original timber treatment.
- Attach at least three rails of 3.8cm x 8.7cm sawn timber, skew nailed to the posts. Additional rails may be added where necessary.
- Attach rails on the 'stock' side of the posts, to prevent stock pushing rails off posts.
- Alternate joints between rails on the posts, as shown on the diagram.
- Ensure there is at least 1m from the ground to the top of the uppermost rail.

Do not:

- Use trees and shrubs as strainers or fencing posts, or attach wire, staples or netting to them.
- Use concrete to secure the posts as it promotes rotting of the posts at ground level.

Requirements and guidance in addition to the specifications above:

- Best practice is to set the posts at least 70cm into the ground to ensure stability, and secure the posts with rammed earth and stone.
- Ensure that you have the appropriate Flood Risk Activity Permit if you are planting or fencing near a main river, flood plain or flood defence structure. Alternatively, ensure you have the appropriate Ordinary Water Course Consent if you are carrying out works near an ordinary water course. What may be considered a ditch may be an ordinary watercourse, so consent may be required. As such, the permit/consent (or confirmation that a permit/consent is not needed) should be retained and made available on request. See Terms and Conditions for more details.
- Where INRS activities include the installation of access furniture such as stiles or gates on a Public Right of Way, it is your responsibility to ensure you obtain approval under Section 147 of the Highways Act, 1980, from the appropriate Highway Authority.

Example of a Post and Rail Fence

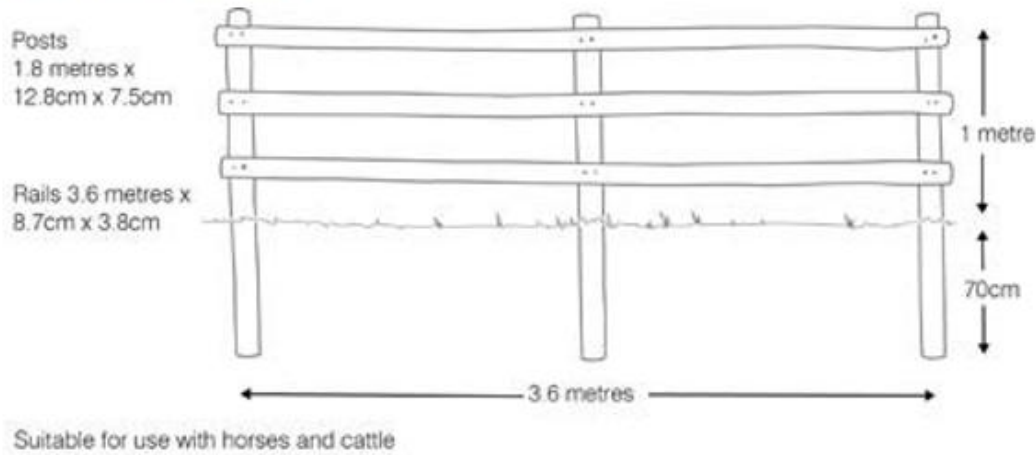

Post and Wire Fencing

Item Code: D021

Payment Rate: £5.81

This technical note describes the minimum standard of work required in order to receive payments for 'Post and Wire Fencing'.

Any variation must be approved by the Welsh Government prior to starting the work.

You must adhere to the following:

- Ensure that you have obtained, and adhere to any licences, consents or permissions that are needed.
- Use fencing timber comprising either hardwood or pressure treated softwood.
- Ensure that timbers, wire, netting and galvanised staples consist of new materials.
- Attach at least three lines of wire made up of either galvanised mild steel wire (4mm gauge) or two ply twisted barbed wire (2.5mm gauge). The top wires of any fencing erected next to public access routes must consist of plain wire or an additional line of plain wire must be affixed to the outside of the posts closest to the route in question.
- Use straining posts that are a minimum of 12.5cm cross section and at least 2m long. Straining posts must be set into the ground at a sufficient depth to ensure stability. Straining posts must be placed at either end of the fence line and at centres of 100m or less, as well as at every horizontal or vertical change of direction.
- Attach struts at each end of the fence line and at all changes of slope and direction. Struts must have a top diameter of at least 6.5cm and must be supported to prevent them splaying outwards.
- Use intermediate posts that are at least 6.5cm diameter (round posts and sawn timber) and at least 1.7m long. Half round posts are acceptable provided they measure at least 6.5cm from the midpoint of the sawn side to the mid-point of the round side. Intermediate posts must be set at centres of 3m or less.
- Attach wire to posts with galvanised staples.
- Attach the top wire no less than 1.05m from the ground.
- Ensure that the new fencing conforms to British Standards 1722 and 4102, as amended.

Do not:

- Use trees and shrubs as strainers or fencing posts, or attach wire, staples or netting to them.

Requirements and guidance in addition to the specifications above:

- Best practice is to set the posts at least 1m into the ground to ensure stability.
- Diagonal struts must be supported with either a base plate or a suitably positioned intermediate post to prevent them splaying outwards.
- Ensure that you have the appropriate Flood Risk Activity Permit if you are planting or fencing near a main river, flood plain or flood defence structure. Alternatively, ensure you have the appropriate Ordinary Water Course Consent if you are carrying out works near an ordinary water course. What may be considered a ditch may be an ordinary watercourse, so consent may be required. As such, the permit/consent (or confirmation that a permit/consent is not needed) should be retained and made available on request. See Terms and Conditions for more details.
- Where INRS activities include the installation of access furniture such as stiles or gates on a Public Right of Way, it is your responsibility to ensure you obtain approval under Section 147 of the Highways Act, 1980, from the appropriate Highway Authority.

Example Diagram of Three Line Wire Fence

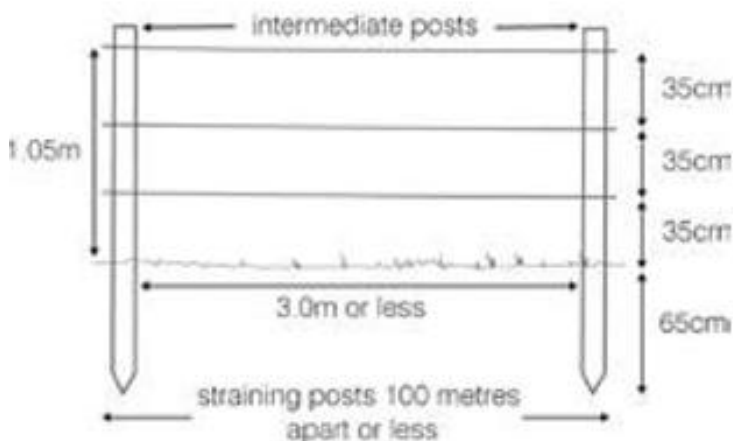

Timber Field Gates (Hardwood)

Item Code: D022

Payment Rate: £466.22

This technical note describes the minimum standard of work required in order to receive payments for 'Timber Field Gates (Hardwood)'. Any variation must be approved by the Welsh Government prior to starting the work.

You must adhere to the following:

- Install timber field gates that are at least 2.4m wide, but no more than 4.2m wide. Any openings greater than 4.2m must have two leaves.
- Use timber field gates constructed from hardwood only, which complies with the dimensions set out in the diagram below.
- Use timber field gates that conform to the specifications set out in the diagram below as well as those of British Standard 3470, as amended.
- Hang gates on timber gate posts at least 2.1m long. Hanging posts must be at least 200mm x 200mm in cross section. Shutting posts must be at least 175mm x 175mm in cross section.
- Set gateposts correctly into the ground, using concrete if necessary and fit with appropriate hangings and latches.

Do not:

- Use hanging or shutting posts as straining posts for fencing. A short length of split timber should be used to form a horizontal strut between the gate post and adjacent straining post.
- Use second hand material for constructing gates unless approved in advance by the Welsh Government.

Example of Timber Field Gate (Hardwood)

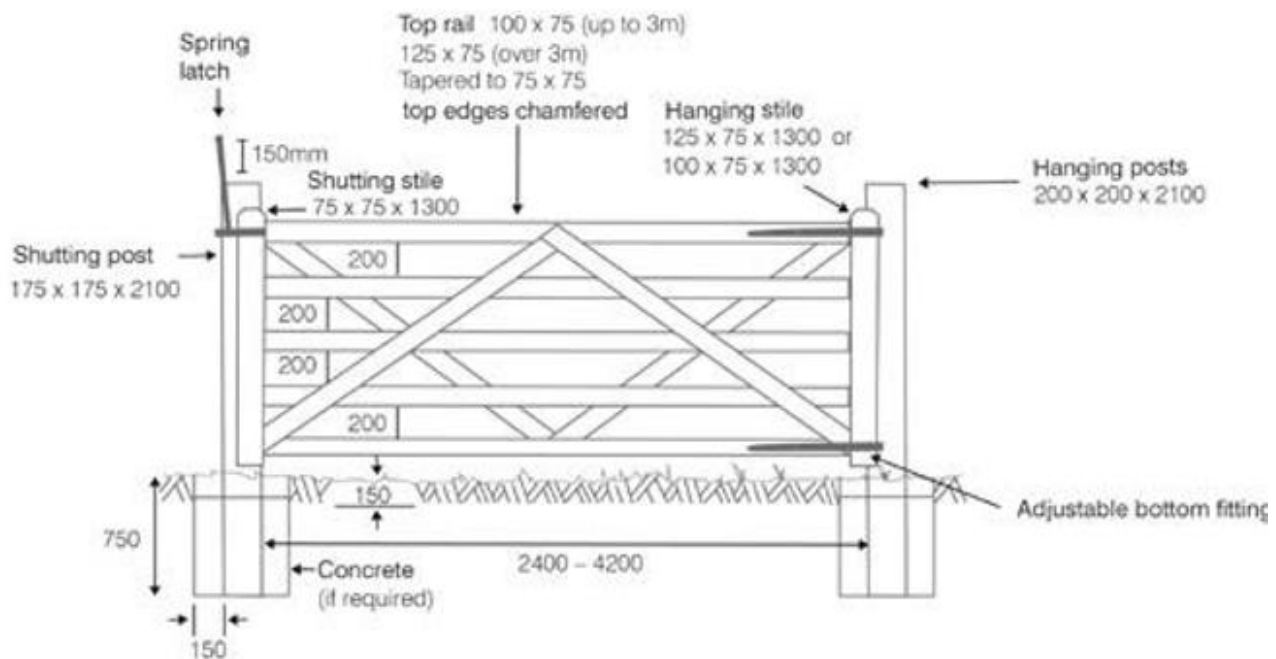

Timber Field Gates (Softwood)

Item Code: D023

Payment Rate: £225.92

This technical note describes the minimum standard of work required in order to receive

payments for 'Timber Field Gates (Softwood)'. Any variation must be approved by the Welsh Government prior to starting the work.

You must adhere to the following:

- Install timber field gates that are at least 2.4m wide, but no more than 4.2m wide. Any openings greater than 4.2m must have two leaves.
- Use timber field gates constructed from hardwood or pressure treated softwood, which complies with the dimensions set out in the diagram below.
- Use timber field gates that conform to the specifications set out in the diagram below as well as those of British Standard 3470.
- Fit the wooden gate to hang on a post at least 2.1m long. Each hanging post will have a minimum cross section of 200mm x 200mm and closing posts will have a cross section of 175mm x 175mm.
- Set gateposts correctly into the ground, using concrete if necessary and fit with appropriate hangings and latches.

Do not:

- Use hanging posts or shutting posts as straining posts for fencing. A short length of split timber should be used to form a horizontal strut between the gate post and adjacent straining post.
- Use second hand material for constructing gates unless approved in advance by the Welsh Government.

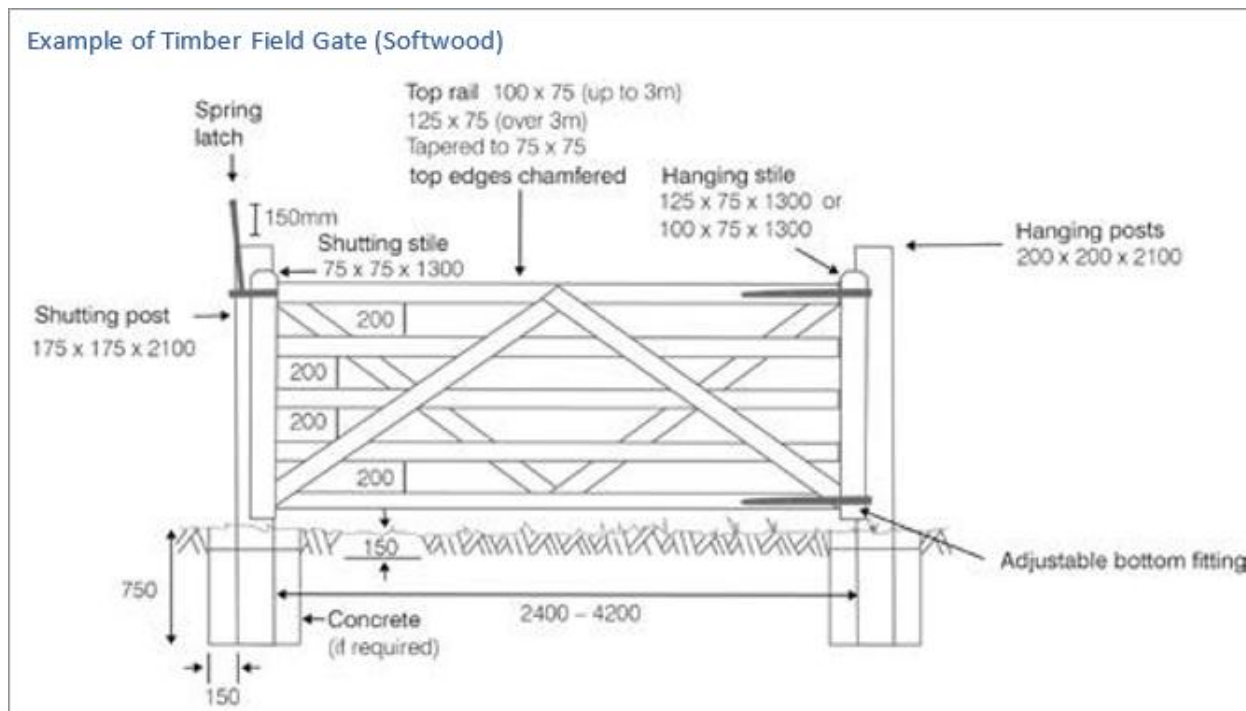

Parkland Tree Stock Guards

Item Code: D024**Payment Rate: £94.40**

This technical note describes the minimum standard of work required in order to receive payments for 'Parkland Tree Stock Guards'. Any variation must be approved by the Welsh Government.

You must adhere to the following:

- Install tree guards that are large enough and designed correctly to protect from any livestock that will have access to the land.
- All guards constructed from timber rails must be at least 1.2m high and set at least 1m from the tree to protect against sheep (or 1.5m to protect against cattle and horses). Each of the 4 corner posts should have a minimum diameter of 10cm x 10cm. At least 4 wooden rails with a minimum diameter of 10cm x 5cm should be fixed to the outside of the posts. Galvanised netting should then be fixed around the outside of the structure and held in place with galvanised staples. Triangular shaped enclosures are only acceptable in parklands where sheep are the sole livestock.
- Use fencing timber comprising either hardwood or pressure treated softwood.
- Ensure that timbers, wire, netting and galvanised staples consist of new materials.
- If traditional metal guards are used rather than wooden guards, ensure they are sufficiently sized to protect from all livestock.

Requirements and guidance in addition to the specifications above:

- The choice of tree guard will depend upon:
 - The size of tree to be protected.
 - The type of damage expected, e.g. browsing, bark stripping, fraying.
 - Type of animal most likely to cause damage.
 - Period of time the tree is at risk from damage.
 - The visual appearance of the guard (UKWAS General Forest Practice 24 Consider the impact of fencing on landscape).
- Use a combination of vertical posts and horizontal rails to build a rigid structure. Fix wire netting around it to prevent access by livestock. The horizontal rails will prevent the posts from being loosened. A variety of stock might have access to the parkland over time so the guard must be strong enough to withstand the worst case scenario. Do not try to increase the distance of the top rail from the tree by slanting the posts outwards. This will make it difficult to fix the netting securely in place.
- It is not necessary to top the enclosure with barbed wire as this is unlikely to stop animals leaning over, and you will make it more difficult to get into the enclosure to tend the tree. Barbed wire may also cause injury to both you and your livestock.
- Additional sets of rails may also be placed mid way up the posts to provide additional strength.
- Triangular shaped enclosures are only acceptable in parklands where sheep are the sole livestock. Such enclosures must be at least 1.2m high and set at least
- 1m from the tree to protect against sheep. It is important to remember that as the tree grows it may be necessary to widen the guard.
- Traditional metal types of guards are used in long established parklands. It is important that they are checked regularly to ensure that the tree does not grow into the metal work and become deformed.
- Such guards were originally made out of wrought iron but are now available in mild steel.

Examples of Parkland Tree Guards

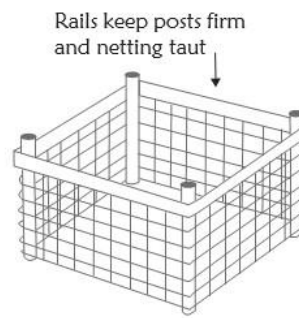
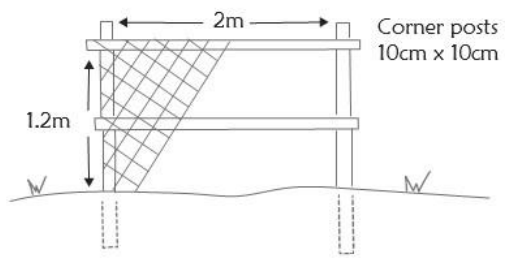

a) Suitable for use with

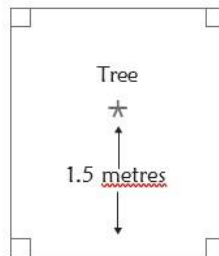
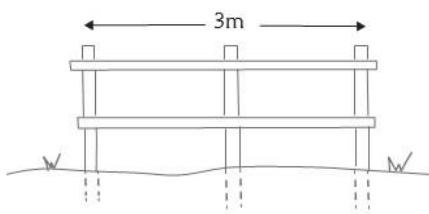

b) Suitable for use with horses and

3. Traditional Metal Types

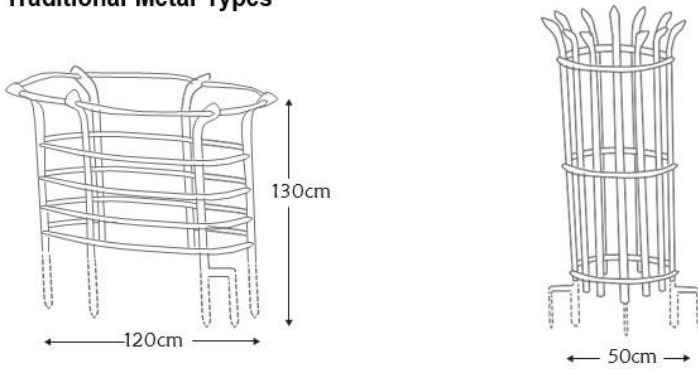

2. Traditional Tree Guard

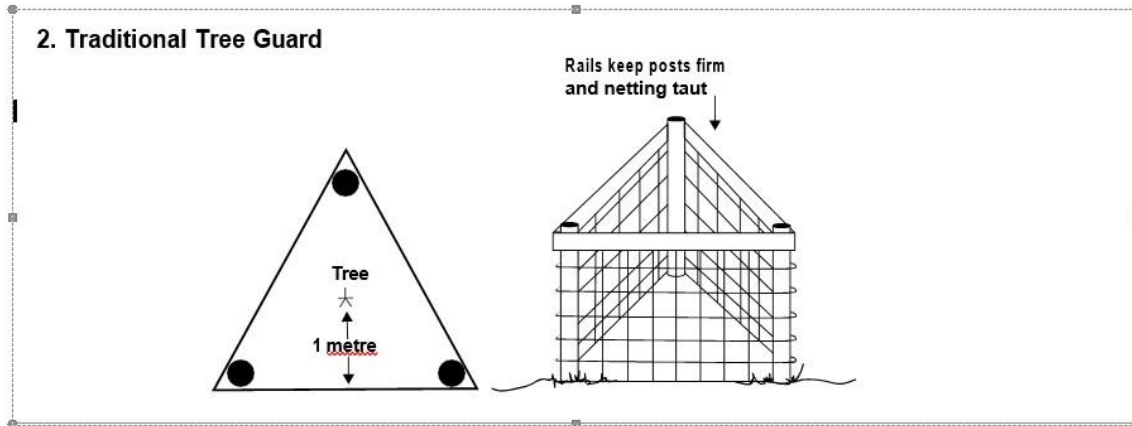

Tree Shelter (60cm With Stake)

Item Code: D025

Payment Rate: £2.21

This technical note describes the minimum standard of work required in order to receive payments for 'Tree Shelter (60cm with stake)'. Any variation must be approved by the Welsh Government prior to starting the work.

Newly planted trees and shrubs only need protection where animals or machinery might damage them. Fencing will usually provide more economic protection for groups of trees and shrubs against machinery or large browsing animals, in combination with spiral rabbit guards to protect against rabbits and hares.

Individual tree shelters and stakes can also be used where lengths of fencing would be unsightly, for example in parklands.

You must adhere to the following:

- Insert a stake vertically into the ground next to each newly planted tree. The stake should have a diameter of 2.5cm x 2.5cm on sheltered sites and 3cm x 3cm on more exposed sites.
- Fix all tree shelters to the stake with wire or plastic cable clips.
- Ensure that the stake is no taller than the shelter.

Do not:

- Allow weeds to grow inside the shelters.

Requirements and guidance in addition to the specifications above:

- Tree shelters to protect young trees are translucent plastic tubes up to 2m in height, with a diameter of up to 12cm. They are constructed of twin wall polypropylene.
- Each shelter should provide support and protection for some 5 -10 years before it biodegrades.
- Although shelters come in a range of colours, there is little difference between them in terms of tree growth. When planting under established trees, where light intensity is likely to be low, it is generally better to use clear translucent tubes.
- Tree shelters need to be above the browse height of the animal. This can vary from 60cm for rabbits and hares, to 2m for Roe deer. Sheep can browse at 1.2m-1.5m high.
- The removal of weeds around trees and in shelters is crucial as the weeds can compete for nutrients and light. Trees in tree shelters must be weeded for the first 2-3 years of life. Weeds growing inside the tree shelter must also be removed. This can be done by lifting the shelter slightly and carefully pulling the weeds out from the tube by hand.
- Any plants that have been loosened or partly lifted by winds and winter frosts should be trodden back in carefully. Regularly inspect fencing, tree guards, stakes and tree ties (loosen tight ties as these will constrict tree growth) and prevent trees growing through or chafing against tree guards.

Trees Standards

Item Code: D026

Payment Rate: £24.35

This technical note describes the minimum standard of work required in order to receive payments for 'Trees Standards (no fencing)'. Any variation must be approved by the Welsh Government.

Growing trees remove carbon dioxide from the atmosphere (which has a positive impact on climate change) and absorb a lot of water, reducing the amount of water running off farmland. Standard trees in hedgerows are also standout features in the landscape and provide many benefits for our native biodiversity.

You must adhere to the following:

- Plant sturdy plants, which are at least 1.8m in height.
- Plant only native species as shown on the table below.
- Trees and shrubs need to be UK grown and ideally from Plant Healthy stock for biosecurity reasons.

Do not:

- Plant ash trees as part of any planting mix due to ash dieback disease (*Hymenoscyphus fraxinea*).
- Allow damage from machinery or browsing animals (including wild animals).

Requirements and guidance in addition to the specifications above:

- Standard trees in new hedgerows should be established individually, ideally at approximately 50m – 100m spacings.
- You must protect the standard trees from browsing using a tree shelter (see E608 Tree Shelter (60cm With Stake)) and the tree planting must be carried out within the newly created hedgerow.
- Ensure you have the appropriate Flood Risk Activity Permit if you are planting or fencing near a main river, flood plain or flood defence structure. Also, ensure you have the appropriate Ordinary Water Course Consent if you are carrying out works near an ordinary water course. What may be considered a ditch may be an ordinary watercourse, so consent may be required. As such, the permit/consent, or confirmation that a permit/consent is not needed, should be retained, and made available on request. See General Rules for more details.
- If undertaking any spraying as part of this activity ensure you have obtained any consents that may be necessary.
- Where INRS activities include the installation of access furniture such as stiles or gates on a Public Right of Way, it is your responsibility to ensure you obtain approval under Section 147 of the Highways Act, 1980, from the appropriate Highway Authority. This will ensure that when the trees are grown, they will not shade the surface of the pond.
- Consideration should also be given when establishing scrub and tree cover to avoid any impact on water supply for ponds or the likelihood of damaging any pond lining.
- The planting season normally runs from 1 October to 30 April. In practice, frost and snow usually divides this period into two planting spells: October to December; and during March. At higher altitudes, planting can be extended into early April.
- Autumn planting is preferred for broadleaved trees and shrubs, as roots will grow in warm spells and lessen the effect of any subsequent spring drought. In exposed sites or areas where winter storms are likely, spring planting may be preferable.
- Order as far in advance as possible to ensure the correct trees are available. Request that plants are delivered as close as possible to the planting date. It is best to choose an established local nursery, because they will usually have a reputation to maintain the trees and your transport costs should be lower. In addition, the plants will be out of the ground for the minimum length of time.
- Wherever possible, try to obtain plants grown from locally obtained seeds or cuttings (native provenance), since these will do better under local conditions and are more valuable for wildlife than imported stock.
- Try to be on hand when plants arrive so you can ensure they are in good physical condition. Keep the roots covered at all times before planting to prevent damage and drying out. Whilst cold is unlikely to be harmful, hot sun and any form of drying, such as wind, can very quickly cause damage or kill the plants.
- If immediate planting is not possible, dig a trench before delivery and store plants in this with the roots covered so they are kept moist and cool. Protect the plants from animals, including small mammals.
- There are four main methods of planting using a spade, which are illustrated at the end of the tree planting notes. More specialised tools are available for use on large scale plantings.
- Annual maintenance is essential to ensure both survival and healthy growth. Plants should be watered both regularly and liberally during prolonged dry spells. It is advisable to apply water slowly, so it has time to soak into the ground adjacent to the tree. A mulch may serve to reduce the frequency with which watering is needed.

- Plants should be kept clear of competing weeds and grasses (weeding will also reduce mouse and vole damage). Control can be achieved with a thick mulch of bark chippings or by using a 500-gauge black polythene sheet and pegging down securely. Alternatively, carefully cut back grass and other vegetation in the area above the tree roots.
- Weeding is advisable twice in the first year after planting and once a year thereafter, until the tree is clear of surrounding vegetation. Cut weeds by hand or use herbicides to control grasses, docks, thistles, and ragwort. If using a strimmer, take care to protect the tree stem from damage. Any chemicals used must have a label recommendation for use on the target species and for the intended method of application. All manufacturers label recommendations regarding method of application must be strictly adhered to.
- Any plants that have been loosened or partly lifted by winds and winter frosts should be trodden back in carefully. Regularly inspect fencing, tree guards, stakes, and tree ties (loosen tight ties as these will constrict tree growth) and prevent trees growing through or chafing against tree guards.

For an extensive list of trees native to Wales, see Forest Research's [Using Local Stock for Planting Native Trees and Shrubs](#) (zones 303 and 304 apply).

Suggested Native Trees and Shrubs Suitable for Planting			
Alder	Cherry (Wild & Bird)	Guelder Rose	Rowan (Mountain Ash)
Aspen	Crab Apple	Hawthorn	Scots Pine
Beech	Dog Rose	Hazel	Spindle
Birch (Silver & Downy)	Elder	Holly	Willow (Crack, Goat & Grey)
Blackthorn	Field Maple	Lime (Small & large leaved)	White Poplar
Black Poplar		Oak (Sessile & Pedunculate)	Yew

Example of the four main methods of planting using a spade

1. Pit Planting

Use for large plants or those with bulky root systems

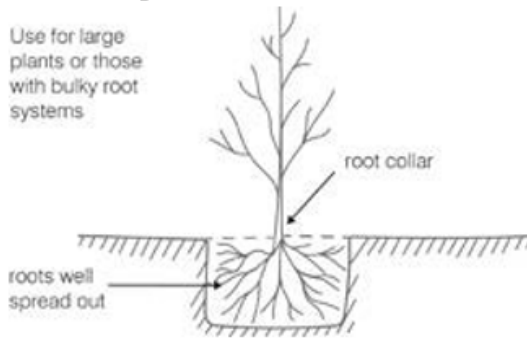

2. Turf Planting

Use on wet sites with poor soil

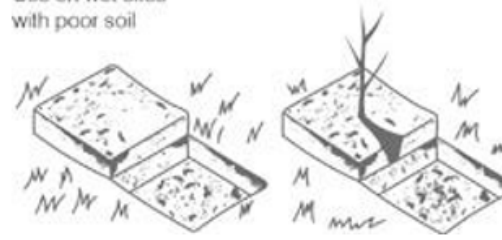

3. Notch or Slit Planting

Use for smaller plants with compact root systems

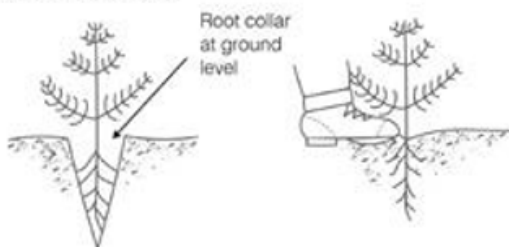

4. Ridge or Mount Planting

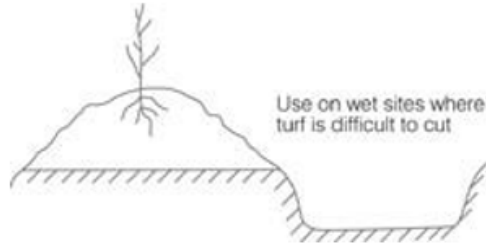

Trees Standards (no fencing)

Item Code: D027

Payment Rate: £24.35

This technical note describes the minimum standard of work required in order to receive payments for 'Trees Standards (no fencing)'. Any variation must be approved by the Welsh Government.

Growing trees remove carbon dioxide from the atmosphere (which has a positive impact on climate change) and absorb a lot of water, reducing the amount of water running off farmland. Standard trees in hedgerows are also standout features in the landscape and provide many benefits for our native biodiversity.

You must adhere to the following:

- Plant sturdy plants, which are at least 1.8m in height.
- Plant only native species as shown on the table below.
- Trees and shrubs need to be UK grown and ideally from Plant Healthy stock for biosecurity reasons.

Do not:

- Plant ash trees as part of any planting mix due to ash dieback disease (*Hymenoscyphus fraxinea*).
- Allow damage from machinery or browsing animals (including wild animals).

Requirements and guidance in addition to the specifications above:

- Standard trees in new hedgerows should be established individually, ideally at approximately 50m – 100m spacings.
- You must protect the standard trees from browsing using a tree shelter (see E608 Tree Shelter (60cm With Stake)) and the tree planting must be carried out within the newly created hedgerow.
- Ensure you have the appropriate Flood Risk Activity Permit if you are planting or fencing near a main river, flood plain or flood defence structure. Also, ensure you have the appropriate Ordinary Water Course Consent if you are carrying out works near an ordinary water course. What may be considered a ditch may be an ordinary watercourse, so consent may be required. As such, the permit/consent, or confirmation that a permit/consent is not needed, should be retained, and made available on request. See General Rules for more details.
- If undertaking any spraying as part of this activity ensure you have obtained any consents that may be necessary.
- Where INRS activities include the installation of access furniture such as stiles or gates on a Public Right of Way, it is your responsibility to ensure you obtain approval under Section 147 of the Highways Act, 1980, from the appropriate Highway Authority. This will ensure that when the trees are grown, they will not shade the surface of the pond.
- Consideration should also be given when establishing scrub and tree cover to avoid any impact on water supply for ponds or the likelihood of damaging any pond lining.
- The planting season normally runs from 1 October to 30 April. In practice, frost and snow usually divides this period into two planting spells: October to December; and during March. At higher altitudes, planting can be extended into early April.
- Autumn planting is preferred for broadleaved trees and shrubs, as roots will grow in warm spells and lessen the effect of any subsequent spring drought. In exposed sites or areas where winter storms are likely, spring planting may be preferable.
- Order as far in advance as possible to ensure the correct trees are available. Request that plants are delivered as close as possible to the planting date. It is best to choose an established local nursery, because they will usually have a reputation to maintain the trees and your transport costs should be lower. In addition, the plants will be out of the ground for the minimum length of time.
- Wherever possible, try to obtain plants grown from locally obtained seeds or cuttings (native provenance), since these will do better under local conditions and are more valuable for wildlife than imported stock.
- Try to be on hand when plants arrive so you can ensure they are in good physical condition. Keep the roots covered at all times before planting to prevent damage and drying out. Whilst cold is unlikely to be harmful, hot sun and any form of drying, such as wind, can very quickly cause damage or kill the plants.
- If immediate planting is not possible, dig a trench before delivery and store plants in this with the roots covered so they are kept moist and cool. Protect the plants from animals, including small mammals.
- There are four main methods of planting using a spade, which are illustrated at the end of the tree planting notes. More specialised tools are available for use on large scale plantings.
- Annual maintenance is essential to ensure both survival and healthy growth. Plants should be watered both regularly and liberally during prolonged dry spells. It is advisable to apply water slowly, so it has time to soak into the ground adjacent to the tree. A mulch may serve to reduce the frequency with which watering is needed.

- Plants should be kept clear of competing weeds and grasses (weeding will also reduce mouse and vole damage). Control can be achieved with a thick mulch of bark chippings or by using a 500-gauge black polythene sheet and pegging down securely. Alternatively, carefully cut back grass and other vegetation in the area above the tree roots.
- Weeding is advisable twice in the first year after planting and once a year thereafter, until the tree is clear of surrounding vegetation. Cut weeds by hand or use herbicides to control grasses, docks, thistles, and ragwort. If using a strimmer, take care to protect the tree stem from damage. Any chemicals used must have a label recommendation for use on the target species and for the intended method of application. All manufacturers label recommendations regarding method of application must be strictly adhered to.
- Any plants that have been loosened or partly lifted by winds and winter frosts should be trodden back in carefully. Regularly inspect fencing, tree guards, stakes, and tree ties (loosen tight ties as these will constrict tree growth) and prevent trees growing through or chafing against tree guards.

For an extensive list of trees native to Wales, see Forest Research's [Using Local Stock for Planting Native Trees and Shrubs](#) (zones 303 and 304 apply).

Suggested Native Trees and Shrubs Suitable for Planting			
Alder	Cherry (Wild & Bird)	Guelder Rose	Rowan (Mountain Ash)
Aspen	Crab Apple	Hawthorn	Scots Pine
Beech	Dog Rose	Hazel	Spindle
Birch (Silver & Downy)	Elder	Holly	Willow (Crack, Goat & Grey)
Blackthorn	Field Maple	Lime (Small & large leaved)	White Poplar
Black Poplar		Oak (Sessile & Pedunculate)	Yew

Example of the four main methods of planting using a spade

1. Pit Planting

Use for large plants or those with bulky root systems

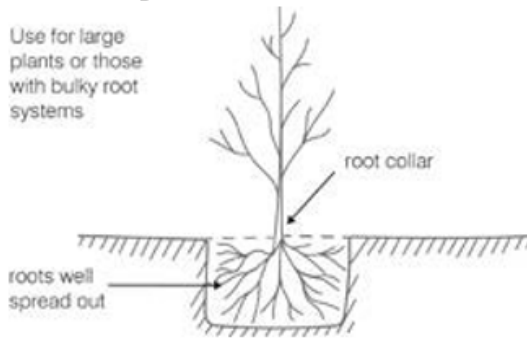

2. Turf Planting

Use on wet sites with poor soil

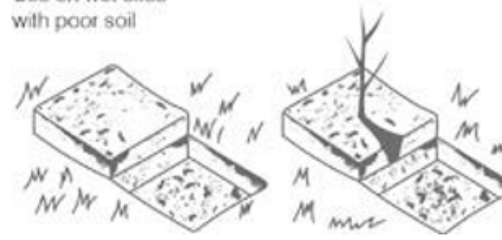

3. Notch or Slit Planting

Use for smaller plants with compact root systems

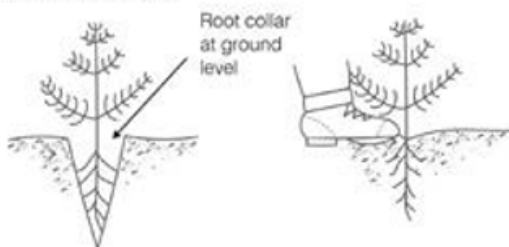

4. Ridge or Mount Planting

Use on wet sites where turf is difficult to cut

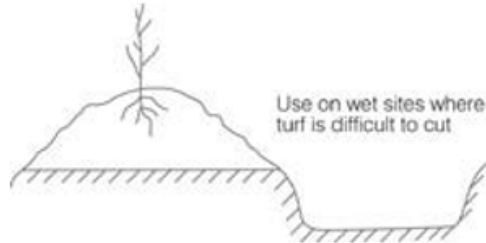

Trees and Shrubs (Transplants)

Item Code: D028

Payment Rate: £2.03

This technical note describes the minimum standard of work required in order to receive payments for 'Trees and Shrubs (Transplants)'. Any variation must be approved by the Welsh Government prior to starting the work.

Planting small areas of woodland can provide benefits for wildlife and landscape. Growing trees removes carbon dioxide from the atmosphere (which has a positive impact on climate change) and absorbs a lot of water, reducing the amount of water running off farmland into rivers.

You must adhere to the following:

- Plant sturdy plants, which are at least 50cm in height.
- Plant only native species, as shown on the table below.
- Trees and shrubs need to be UK grown and ideally from Plant Healthy stock for biosecurity reasons

Do not:

- Plant ash trees as part of any planting mix due to ash dieback disease (*Hymenoscyphus fraxineus*).
- Allow damage from machinery or browsing animals (including wild animals).

Requirements and guidance in addition to the specifications above:

- You can establish trees individually or in groups of trees.
- If you are planting trees in groups, they must be established at a planting density equivalent to 400 to 2500 trees per hectare. The width of the area used to plant a group of trees can be up to a maximum width of 10m wide in any field parcel. The 10m maximum width limit will be taken from the mapped fence line to the mapped field boundary, which may already include an existing field boundary, such as a hedge, so you may have to include this when establishing the 10m width. You must protect the trees from browsing using spiral rabbit guards or tubes and the area of tree planting must also be fenced to exclude livestock.
- Ensure you have the appropriate Flood Risk Activity Permit if you are planting or fencing near a main river, flood plain or flood defence structure. Also, ensure you have the appropriate Ordinary Watercourse Consent if you are carrying out works near an ordinary watercourse. What may be considered a ditch may be an ordinary watercourse, so consent may be required. As such, the permit/consent, or confirmation that a permit/consent is not needed, should be retained and made available on request. See General Rules for more details.
- If undertaking any spraying as part of this activity, ensure you have obtained any consents that may be necessary.
- Where INRS activities include the installation of access furniture, such as stiles or gates on a Public Right of Way, it is your responsibility to ensure you obtain approval under Section 147 of the Highways Act, 1980, from the appropriate Highway Authority.
- Transplants are 1-2 year old plants with a large proportion of root in relation to shoot, which gives them good powers of survival, especially in poor soils and on exposed sites. They will generally outgrow whips in a few years to produce healthier, better-formed trees. A high degree of protection from machinery and animals is needed. Careful maintenance during the first few years is essential. They are considerably cheaper than whips and standards and are usually purchased in bulk.
- Where possible, trees or shrubs should not be planted within 15 metres of ponds. This will ensure, when the trees are grown, they will not shade the surface of the pond. Consideration should also be given when establishing scrub and tree cover to avoid any impact on water supply for ponds or the likelihood of damaging any pond lining.
- The planting season normally runs from 1 October to 30 April. In practice, frost and snow usually divides this period into two planting spells: October to December and during March. At higher altitudes, planting can be extended into early April.
- Autumn planting is preferred for broadleaved trees and shrubs, as roots will grow in warm spells and lessen the effect of any subsequent spring drought. In exposed sites or areas, where winter gales are likely, spring planting may be preferable.
- Order as far in advance as possible to ensure the correct trees are available. You should request plants are delivered as close as possible to the planting date. It is best to choose an established local nursery because your transport costs should be lower. In addition, the plants will be out of the ground for the minimum length of time.
- Wherever possible, try to obtain plants grown from locally obtained seeds or cuttings (native provenance), since these will do better under local conditions and are more valuable for wildlife than imported stock.

- Try to be on hand when plants arrive so you can ensure they are in good physical condition. Keep the roots covered at all times before planting to prevent damage and drying out. Whilst cold is unlikely to be harmful, hot sun and any form of drying such as wind, can very quickly cause damage or kill the plants.
 - If immediate planting is not possible, dig a trench before delivery and store plants in this with the roots covered so they are kept moist and cool. Protect the plants from animals, especially small mammals.
 - There are four main methods of planting using a spade, which are illustrated in this note. More specialised tools are available for use on large-scale plantings.
 - Use individual tree guards and stakes where lengths of fencing would be uneconomic or unsightly, such as single or widely spaced trees in parklands, or where damage from machinery is possible.
 - Annual maintenance is essential to ensure both survival and healthy growth. Plants should be watered, both regularly and liberally, during prolonged dry spells. It is advisable to apply water slowly so it has time to soak into the ground adjacent to the tree. A mulch may serve to reduce the frequency with which watering is needed.
 - Plants should be kept clear of competing weeds and grasses (weeding will also reduce mouse and vole damage). Control can be achieved with a thick mulch of bark chippings or by using a 500-gauge black polythene sheet and pegging down securely. Alternatively, carefully cut back grass and other vegetation in the area above the tree roots.
 - Weeding is advisable twice in the first year after planting and once a year thereafter, until the tree is clear of surrounding vegetation. Cut weeds by hand or use herbicides to control grasses, docks, thistles and ragwort. If using a strimmer, take care to protect the tree stem from damage. Any chemicals used must have a label recommendation for use on the target species and for the intended method of application. All manufacturers label recommendations regarding method of application must be strictly adhered to.
- Any plants that have been loosened or partly lifted by winds and winter frosts should be trodden back in carefully. Regularly inspect fencing, tree guards, stakes and tree ties (loosen tight ties as these will constrict tree growth) and prevent trees growing through or chafing against tree guards.

Suggested Native Trees and Shrubs Suitable for Planting			
Alder	Cherry (Wild & Bird)	Guelder Rose	Rowan (Mountain Ash)
Aspen	Crab Apple	Hawthorn	Scots Pine
Beech	Dog Rose	Hazel	Spindle
Birch (Silver & Downy)	Elder	Holly	Willow (Crack, Goat & Grey)
Blackthorn	Field Maple	Lime (Small & large leaved)	White Poplar
Black Poplar		Oak (Sessile & Pedunculate)	Yew

For an extensive list of trees native to Wales, see Forest Research's [Using Local Stock for Planting Native Trees and Shrubs](#) (zones 303 and 304 apply).

Example of the four main methods of planting using a spade

1. Pit Planting

Use for large plants or those with bulky root systems

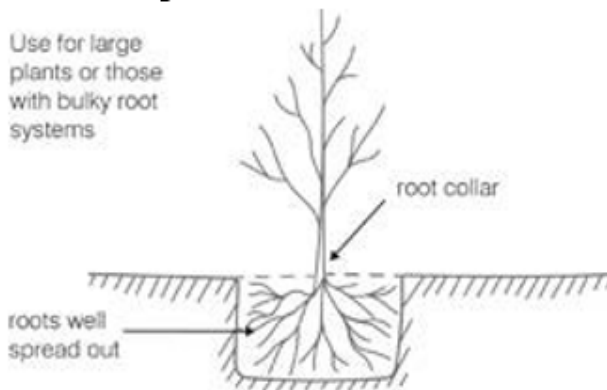

2. Turf Planting

Use on wet sites with poor soil

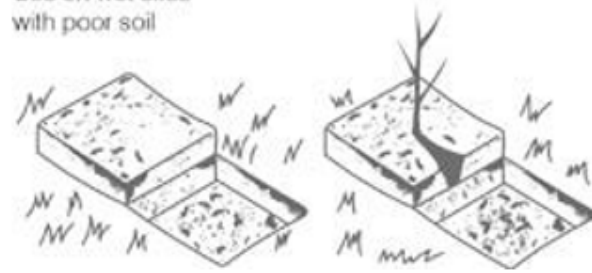

3. Notch or Slit Planting

Use for smaller plants with compact root systems

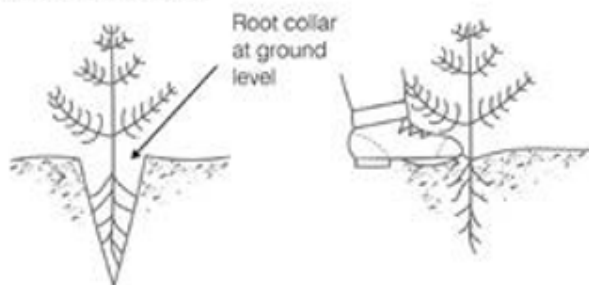

4. Ridge or Mount Planting

Use on wet sites where turf is difficult to cut

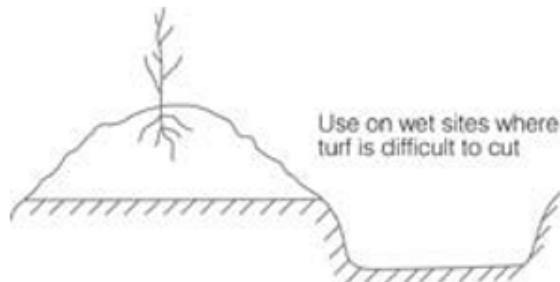

Trees and Shrubs - Whips

Item Code: D029

Payment Rate: £6.32

This technical note describes the minimum standard of work required in order to receive payments for 'Trees and Shrubs – whips'. Any variation must be approved by the Welsh Government.

Planting small areas of woodland can provide benefits for wildlife and landscape. Growing trees removes carbon dioxide from the atmosphere (which has a positive impact on climate change) and absorbs a lot of water, reducing the amount of water running off farmland.

You must adhere to the following:

- Plant sturdy plants, which are at least 1m in height.
- Plant only native species as shown on the table below.
- Trees and shrubs need to be UK grown and ideally from Plant Healthy stock for biosecurity reasons

Do not:

- Plant ash trees as part of any planting mix due to ash dieback disease (*Chalara fraxinea*).
- Allow damage from machinery or browsing animals (including wild animals).

Requirements and guidance in addition to the specifications above:

- You can establish trees individually or in groups of trees.
- If you are planting trees in groups, they must be established at a planting density equivalent to 400 to 2500 trees per hectare. The width of the area used to plant a group of trees can be up to a maximum width of 10m wide in any field parcel. The 10m maximum width limit will be taken from the mapped fence line to the mapped field boundary, which may already include an existing field boundary, such as a hedge, so you may have to include this when establishing the 10m width. You must protect the trees from browsing using spiral rabbit guards or tubes and the area of tree planting must also be fenced to exclude livestock.
- • Ensure that you have the appropriate Flood Risk Activity Permit if you are planting or fencing near a main river, flood plain or flood defence structure. Alternatively, ensure you have the appropriate Ordinary Water Course Consent if you are carrying out works near an ordinary water course. What may be considered a ditch may be an ordinary watercourse, so consent may be required. As such, the permit/consent, or confirmation that a permit/consent is not needed, should be retained and made available on request. See General Rules for more details.
- If undertaking any spraying as part of this activity ensure you have obtained any consents that may be necessary.
- Where INRS activities include the installation of access furniture such as stiles or gates on a Public Right of Way, it is your responsibility to ensure you obtain approval under Section 147 of the Highways Act, 1980, from the appropriate Highway Authority.
- Whips are used for individual tree planting and for hedgerow trees – trees of 1m or taller with little branching. These should be used occasionally, in specific circumstances.
- Although more expensive and less sturdy than transplants, they are cheaper and easier to establish than standards. Usually short enough not to require stakes and ties, they are tall enough to prevent the leading shoots being damaged by hares and are easier to protect from rabbits than transplants. Weeding is less critical but they will need protection from browsing animals and machinery.
- Where possible, trees or shrubs should not be planted within 15 metres of ponds.
- This will ensure that when the trees are grown they will not shade the surface of the pond. Consideration should also be given when establishing scrub and tree cover to avoid any impact on water supply for ponds or the likelihood of damaging any pond lining.
- The planting season normally runs from 1 October to 30 April. In practice, frost and snow usually divides this period into two planting spells: October to December; and during March. At higher altitudes, planting can be extended into early April.
- Autumn planting is preferred for broadleaved trees and shrubs, since roots will grow in warm spells and lessen the effect of any subsequent spring drought. In exposed sites or areas where winter gales are likely, spring planting may be preferable.
- Order as far in advance as possible to ensure the correct trees are available. Request that plants are delivered as close as possible to the planting date. It is best to
- choose an established local nursery because they will usually have a reputation to maintain and your transport costs should be lower. In addition, the plants will be out of the ground for the minimum length of time.

- Wherever possible try to obtain plants grown from locally obtained seeds or cuttings (native provenance), since these will do better under local conditions and are more valuable for wildlife than imported stock.
- Try to be on hand when plants arrive so you can ensure they are in good physical condition. Keep the roots covered at all times before planting to prevent damage and drying out. Whilst cold is unlikely to be harmful, hot sun and any form of drying such as wind, can very quickly cause damage or kill the plants.
- If immediate planting is not possible, dig a trench before delivery and store plants in this with the roots covered so they are kept moist and cool. Protect the plants from animals, including small mammals.
- There are four main methods of planting using a spade, which are illustrated at the end of this note. More specialised tools are available for use on large scale plantings.
- Use individual tree guards and stakes where lengths of fencing would be uneconomic or unsightly, such as single or widely spaced trees in parklands, or where damage from machinery is possible.
- Annual maintenance is essential to ensure both survival and healthy growth. Plants should be watered both regularly and liberally during prolonged dry spells. It is advisable to apply water slowly so it has time to soak into the ground adjacent to the tree. A mulch may serve to reduce the frequency with which watering is needed.
- Plants should be kept clear of competing weeds and grasses (weeding will also reduce mouse and vole damage). Control can be achieved with a thick mulch of bark chippings or by using a 500-gauge black polythene sheet and pegging down securely. Alternatively, carefully cut back grass and other vegetation in the area above the tree roots.
- Weeding is advisable twice in the first year after planting and once a year thereafter, until the tree is clear of surrounding vegetation. Cut weeds by hand or use herbicides to control grasses, docks, thistles and ragwort.
- If using a strimmer take care to protect the tree stem from damage. Any chemicals used must have a label recommendation for use on the target species and for the intended method of application. All manufacturers label recommendations regarding method of application must be strictly adhered to.
- Any plants that have been loosened or partly lifted by winds and winter frosts should be trodden back in carefully. Regularly inspect fencing, tree guards, stakes and tree ties (loosen tight ties as these will constrict tree growth) and prevent trees growing through or chafing against tree guards.

Suggested Native Trees and Shrubs Suitable for Planting			
Alder	Cherry (Wild & Bird)	Guelder Rose	Rowan (Mountain Ash)
Aspen	Crab Apple	Hawthorn	Scots Pine
Beech	Dog Rose	Hazel	Spindle
Birch (Silver & Downy)	Elder	Holly	Willow (Crack, Goat & Grey)
Blackthorn	Field Maple	Lime (Small & large leaved)	White Poplar
Black Poplar		Oak (Sessile & Pedunculate)	Yew

For an extensive list of trees native to Wales, see Forest Research's [*Using Local Stock for Planting Native Trees and Shrubs*](#) (zones 303 and 304 apply).

Example of the four main methods of planting using a spade

1. Pit Planting

Use for large plants or those with bulky root systems

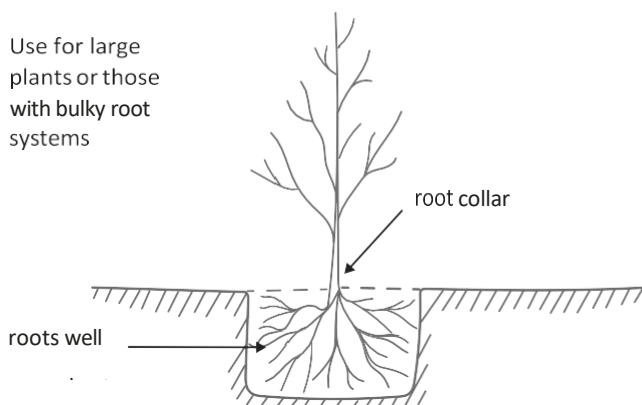

2. Turf Planting

Use on wet sites

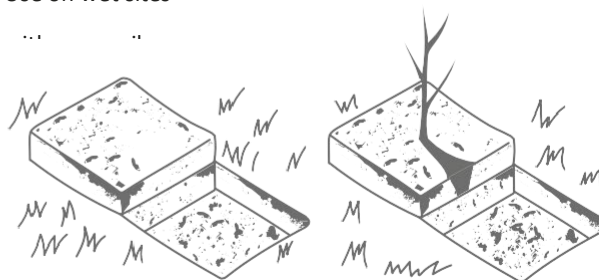

3. Notch or Slit Planting

Use for smaller plants with compact root systems

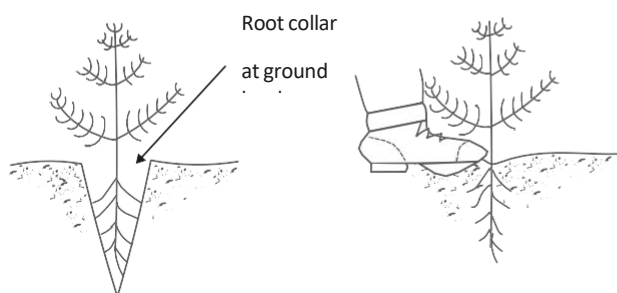

4. Ridge or Mount Planting

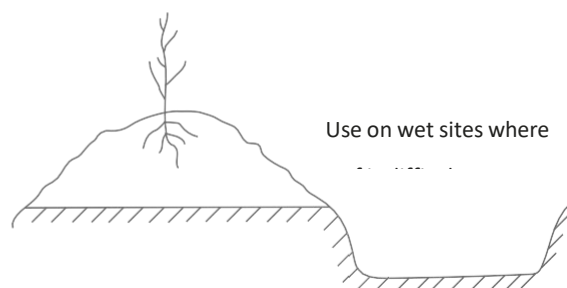

Sabre Planting

Item Code: D030

Payment Rate: £6.94

This technical note describes the standard of work required in order to receive payments for 'Sabre Planting'. Any variation must be approved by the Welsh Government.

Pioneered by an independent local charity 'Bugeiliaid y Coed' (Tree Shepherds), the 'No Fence Planting' technique mimics the way in which self-sown trees establish themselves naturally on grazed farmland.

Trees over 1m in height can be 'sabre-planted' perpendicular to steep ground (rather than pointing straight up) so that the leading shoots cannot be reached by browsing sheep and cattle. Such trees typically have a 'sabre-shaped' profile and can be seen growing in most valleys in Wales.

You must adhere to the following:

- Plant sturdy plants, which are at least 1m in height
- Plant at an angle perpendicular to the slope on steep ground
- Plant only native species as shown on the table below.
- Trees and shrubs need to be UK grown and ideally from Plant Healthy stock for biosecurity reasons

Do not:

- Plant ash trees as part of any planting mix due to ash dieback disease (*Chalara fraxinea*).

Requirements and guidance in addition to the specifications above:

- Trees can be planted amongst gorse.
- Steep and broken ground with bracken is ideal for 'Sabre Planting'.
- Other no-fence methods include the planting of 1.5m-2m trees.
- Where possible, trees or shrubs should not be planted within 15 metres of ponds. This will ensure that when the trees are grown they will not shade the surface of the pond. Consideration should also be given when establishing scrub and tree cover to avoid any impact on water supply for ponds or the likelihood of damaging any pond lining.
- The planting season normally runs from 1 October to 30 April. In practice, frost and snow usually divides this period into two planting spells: October to December; and during March. At higher altitudes, planting can be extended into early April.
- Autumn planting is preferred for broadleaved trees and shrubs, since roots will grow in warm spells and thus lessen the effect of any subsequent spring drought. In exposed sites or areas where winter gales are likely, spring planting may be preferable.
- Order as far in advance as possible to ensure the correct trees are available. Request that plants are delivered as close as possible to the planting date. It is best to choose an established local nursery because they will usually have a reputation to maintain and your transport costs should be lower. In addition, the plants will be out of the ground for the minimum length of time.
- Wherever possible try to obtain plants grown from locally obtained seeds or cuttings (native provenance), since these will do better under local conditions and are more valuable for wildlife than imported stock.
- Try to be on hand when plants arrive so that you can ensure they are in good physical condition. Keep the roots covered at all times before planting to prevent damage and drying out. Whilst cold is unlikely to be harmful, hot sun and any form of drying such as an east wind, can very quickly cause damage or kill the plants.
- If immediate planting is not possible, dig a trench before delivery and store plants in this with the roots covered so they are kept moist and cool. Protect the plants from animals, including rabbits and hares.

Suggested Native Trees and Shrubs Suitable for Planting			
Alder	Cherry (Wild & Bird)	Guelder Rose	Rowan (Mountain Ash)
Aspen	Crab Apple	Hawthorn	Scots Pine
Beech	Dog Rose	Hazel	Spindle
Birch (Silver & Downy)	Elder	Holly	Willow (Crack, Goat & Grey)

Blackthorn	Field Maple	Lime (Small & large leaved)	White Poplar
Black Poplar		Oak (Sessile & Pedunculate)	Yew

For an extensive list of trees native to Wales, see Forest Research's [Using Local Stock for Planting Native Trees and Shrubs](#) (zones 303 and 304 apply).



Spiral Rabbit Guards

Item Code: D031

Payment Rate: £0.58

This technical note describes the minimum standard of work required in order to receive payments for "Spiral Rabbit Guards".

Any variation must be approved by the Welsh Government prior to starting the work. Spiral rabbit guards are the most widely used form of tree protection against rabbits and voles.

You must adhere to the following:

- Ensure each spiral rabbit guard is supported by a bamboo cane.

Do not:

- Use guards that are taller than the tree it is to protect at the time of planting.

Requirements and guidance in addition to the specifications above:

- Spiral rabbit guards are made from a plastic material and are available in three sizes, (45cm, 60cm and 75cm).

- Ideally the bamboo cane should be pushed into the ground next to the newly planted tree. The guard is then wound or spiralled around both tree and cane so that small mammals are excluded.

New Hedge Planting

Item code: D032

Payment Rate: £9.39

This technical note describes the minimum standard of work required in order to receive payments for 'New Hedge Planting'. Any variation must be approved by the Welsh Government prior to starting the work.

You must adhere to the following:

- Plant native trees and shrubs in a mix of at least three hedging species, with no one component of the mix comprising more than 75% of the total.
- Plant hedge plants that are at least 45-60cm high, which should have a strong leader shoot.
- Plant new hedgerows at a density of 7 plants per metre in a staggered double row, with 20cm between each row.
- Prevent new plants from being killed by shading out from excessive weed growth.
- Protect newly planted hedges from livestock.
- Replace any dead plants.
- Ensure there is at least 1m between new planting and protective fencing.
- Ensure that the hedge is able to grow to a 3m width. There must be a gap of at least 3m between double fences. Where a new hedge is planted beside a road, a 1.5m gap from the centre of the hedge to the fence is permissible. The fence must be located on the field side of the hedge.
- Obtain your neighbour's written consent to place a fence on their land if you are planting a new hedge on their boundary.

Do not:

- Plant any ash trees as part of any planting mix due to ash dieback disease (*Hymenoscyphus fraxineus*).
- Use trees and shrubs as strainers or fencing posts, or use them to support fencing wire, staples or netting.
- Cause damage to any existing historic hedge banks during ground preparation, planting or fencing.

Requirements and guidance in addition to the specifications above:

- Ensure that you have the appropriate Flood Risk Activity Permit if you are planting or fencing near a main river, flood plain or flood defence structure. Alternatively, ensure you have the appropriate Ordinary Water Course Consent if you are carrying out works near an ordinary watercourse. What may be considered a ditch may be an ordinary watercourse, so consent may be required. As such, the permit/ consent (or confirmation that a permit/ consent is not needed) should be retained and made available on request. See Terms and Conditions for more details.

- If undertaking any spraying as part of this activity ensure you have obtained any consents that may be necessary.
- Where INRS activities include the installation of access furniture such as stiles or gates on a Public Right of Way, it is your responsibility to ensure you obtain approval under Section 147 of the Highways Act, 1980, from the appropriate Highway Authority.
- Ensure the best chances of survival, by planting new hedgerow plants in the winter months from November to March. Keep root balls damp during planting, and water liberally in dry spells until established.
- Select plants with well-developed root systems. Plants which are 3 – 4 years old are recommended
- Prepare the ground for planting by either rotovating, ploughing or digging over during the previous summer. Avoid damaging historic banks during ground preparation by digging manually.
- You may incorporate some well-rotted manure if planting hedge plants on poor soils.
- Plant locally common native species where possible. Plants should be derived from locally collected seed or cuttings if possible as these are likely to survive better and support more species of native wildlife.
- Control weeds by using a mulch of wood chippings or by securely pegging down a 500-gauge black polythene sheet, 1-2m wide at the base of the transplants. Chemical control of grasses, thistles, docks and ragwort may be undertaken.
- Any chemical used must have a label recommendation for use on the listed species and for the intended method of application. All manufacturers label recommendations regarding application of the herbicide must be strictly adhered to.
- Encourage new growth by trimming the transplant back.
- Establish at least 1 – 2 hedgerow trees per 100m. Either plant new saplings (at least 1m tall), or identify existing plants that can develop into trees. It is sensible to tag the tree to avoid accidental damage when hedge trimming. Choose native tree species that grow well in local hedges, as they will contribute to an attractive landscape and can increase the wildlife value of the hedge.
- Spiral guards can be used to protect the hedge from rabbits, although in certain areas rabbit fencing may be a more effective deterrent.

Hedge Coppicing and Gapping Up

Item Code: D033

Payment Rate: £8.82

This technical note describes the minimum standard of work required in order to receive payments for 'Hedge Coppicing and Gapping- up'. Any variation must be approved by the Welsh Government prior to starting the work.

Please note, hedge trimming with a flail cutter does not meet the technical specification necessary to fulfil the requirement of coppicing the hedge at the level set out below. Hedge Coppicing and Gapping-up projects where a hedge has only been trimmed back, will be rejected.

Coppicing

Hedge coppicing must only be carried out on traditional hedgerows. It should not be carried out on lines of trees, such as riparian woodlands. Coppicing is generally undertaken when a hedge

stem is too wide (more than 10cm in width) to lay properly. In some circumstances, the stems may be so wide that you may need to obtain a Felling Licence from Natural Resources Wales. It is your responsibility to check whether or not this is the case.

You must adhere to the following:

- Coppice the hedge to within 7.5cm or less of ground level to allow re-shooting.
- Retain all large, mature trees where undertaking hedgerow renovation work, particularly those with features such as holes, splits, cracks or dense ivy cover; as these provide roosting sites for bats.
- Plant native trees and shrubs in a mix of at least three hedging species, with no one component of the mix comprising more than 75% of the total.
- Plant hedge plants that are at least 45cm – 60cm high and have a strong leader shoot.
- Plant new hedgerows at a density of 7 plants per metre in a staggered double row, with 20cm between each row.
- Prevent new plants from being killed by shading out from excessive weed growth.
- Protect newly planted hedges from livestock.
- Replace any dead plants
- Ensure all redundant fencing or wire is removed.
- Ensure there is at least 1m between new planting and protective fencing.
- Ensure the hedge is able to grow to a 3m width. There must be a gap of at least 3m between double fences. Where a hedge is coppiced beside a road, a 1.5m gap from the centre of the hedge to the fence is permissible. The fence must be located on the field side of the hedge.
- Obtain your neighbour's written consent to place a fence on their land if you are planting a new hedge on their boundary.

Do not:

- Plant ash trees as part of any planting mix due to ash dieback disease (*Hymenoscyphus fraxineus*), in any planting mix, either for woodlands or when establishing or restoring hedgerows.
- Cause damage to any existing hedge banks during ground preparation, planting or fencing.
- Use trees and shrubs as strainers or fencing posts, or use them to support fencing wire, staples or netting.

Requirements and guidance in addition to the specifications above:

- Depending on the volume of timber felled you may need to obtain a felling licence from Natural Resources Wales.
- Ensure that you have the appropriate Flood Risk Activity Permit if you are planting or fencing near a main river, flood plain or flood defence structure. Alternatively, ensure you have the appropriate Ordinary Water Course Consent if you are carrying out works near an ordinary watercourse. What may be considered a ditch may be an ordinary watercourse, so consent may be required. As such, the permit/consent (or confirmation that a permit/consent is not needed) should be retained and made available on request. See Terms and Conditions for more details.
- If undertaking any spraying as part of this activity ensure you have obtained any consents that may be necessary.

- Where INRS activities include the installation of access furniture such as stiles or gates on a Public Right of Way, it is your responsibility to ensure you obtain approval under Section 147 of the Highways Act, 1980, from the appropriate Highway Authority.
- Carry out hedge restoration work between dates permitted by Cross Compliance rules.
- Restricting the hedge restoration dates further to between November and March will be even more beneficial to wildlife such as dormice.
- Ensure the best chances of survival, by planting new hedgerow plants in the winter months from November to March. Keep root balls damp during planting, and water liberally in dry spells until established.
- An additional 1 metre at the base between hedge and fence (on top of the minimum 3 metre width) will create additional wildlife habitat.
- Increasing the species mix beyond the minimum requirement of a 3 species mix will provide a greater selection of food sources for wildlife.
- Select plants with well-developed root systems. Plants which are 3 – 4 years old are recommended.
- Holly and blackthorn are both suitable species to use. Prepare the ground for planting by either rotovating or digging over during the previous summer. Avoid damaging historic banks during ground preparation by digging manually.
- You may incorporate some well-rotted manure if planting hedge plants on poor soils.
- Plant locally common native species where possible. Plants should be derived from locally collected seeds or cuttings if possible as these are likely to survive better and support more species of native wildlife.
- No one component of the mix should comprise more than 75% of the total.
- In previously un-coppiced hedges gaps should be thoroughly cleared of vegetation and hedges cut back to allow healthy growth on both sides.
- Control weeds by using a mulch of wood chippings or by securely pegging down a 500-gauge black polythene sheet, 1m – 2m wide at the base of the transplants. Chemical control of grasses, thistles, docks and ragwort may be undertaken. Any chemical used must have a label recommendation for use on the listed species and for the intended method of application. All manufacturers label recommendations regarding application of the herbicide must be strictly adhered to.
- Encourage new growth by trimming the transplant back.
- Establish at least 1 – 2 hedgerow trees per 100m. Either plant new saplings (at least 1m tall), or identify existing plants that can develop into trees. It is sensible to tag the tree to avoid accidental damage when hedge trimming. Choose native tree species that grow well in local hedges, as they will contribute to an attractive landscape and can increase the wildlife value of the hedge.
- Spiral guards can be used to protect the hedge from rabbits, although in certain areas rabbit fencing may be a more effective deterrent.
- Retain all large mature trees where undertaking hedgerow renovation work, as these can provide roosting sites for bats.
- Where work is required to a tree that has been identified as a bat roost (either because bats are known to be present or where positive signs of bat use have been found), a Habitats Regulations licence from Natural Resources Wales must be obtained.

Hedge Laying

Item Code: D034

Payment Rate: £15.38

This technical note describes the minimum standard of work required in order to receive payments for 'Hedge Laying'. Any variation must be approved by the Welsh Government prior to starting the work.

You must adhere to the following:

- Ensure that all redundant fencing or wire is removed.
- Lay the hedge by partially cutting through suitable stems at ground level, at an angle of approximately 30°.
- Lay the cut stems as close to ground level as possible, and secure in place with stakes.
- Retain all large, mature trees where undertaking hedgerow renovation work, particularly those with features such as holes, splits, cracks or dense ivy cover as these provide roosting sites for bats.
- Ensure there is at least 1m between new planting and protective fencing.
- Ensure that the hedge is able to grow to a 3m width. There must be a gap of at least 3m between double fences. Where a new hedge is planted beside a road, a 1.5m gap from the centre of the hedge to the fence is permissible. The fence must be located on the field side of the hedge.
- You must ensure the entire width of the hedge is laid. If part of the width of a hedge falls outside your boundary, you should not include this hedge, unless you obtain the written consent from your neighbour to do so.
- Obtain your neighbour's written consent to place a fence on their land if you are planting a new hedge on their boundary.

Do not:

- Use wire or baler twine to secure either the stakes or cut stems.
- Plant any ash trees as part of any planting mix due to ash dieback disease (*Hymenoscyphus fraxineus*), in any planting mix, either for woodlands or when establishing or restoring hedgerows.
- Cause damage to any existing hedge banks during ground preparation, planting or fencing.
- Use trees and shrubs as strainers or fencing posts, or use them to support fencing wire, staples or netting.

Requirements and guidance in addition to the specifications above:

- Depending on the volume of timber felled you may need to obtain a felling licence from Natural Resources Wales.
- Ensure that you have the appropriate Flood Risk Activity Permit if you are planting or fencing near a main river, flood plain or flood defence structure. Alternatively, ensure you have the appropriate Ordinary Water Course Consent if you are carrying out works near an ordinary water course. What may be considered a ditch may be an ordinary watercourse, so consent may be required. As such, the permit/consent (or confirmation

that a permit/consent is not needed) should be retained and made available on request. See Terms and Conditions for more details.

- If undertaking any spraying as part of this activity ensure you have obtained any consents that may be necessary.
- Where INRS activities include the installation of access furniture such as stiles or gates on a Public Right of Way, it is your responsibility to ensure you obtain approval under Section 147 of the Highways Act, 1980, from the appropriate Highway Authority.
- Carry out hedge restoration work between dates permitted by Cross Compliance rules.
- Restricting the hedge restoration dates further to between November and March will be even more beneficial to wildlife such as dormice.
- Stems for laying should be about 5cm – 10cm thick at the base, and 2.5m – 3.5m in height. Beyond this stage coppicing should be considered as a more suitable alternative.
- An additional 1 metre at the base between hedge and fence (on top of the minimum 3 metre width) will create additional wildlife habitat.
- If planting any gaps, using the widest selection of species available will provide a greater selection of food sources for wildlife.
- Aim to lay hedges in the winter months between November and March.
- Whenever possible follow local traditional methods and customs.
- In the interest of biodiversity, remove only as much elder as is necessary and cut back any bramble, briar or other climbing growth where this impedes laying operations.
- Hedge laying should aim to be upslope and in the same direction wherever possible.
- Maintain existing ash trees where possible.
- Retain all large mature trees where undertaking hedgerow renovation work, as these can provide roosting sites for bats.
- Where work is required to a tree that has been identified as a bat roost (either because bats are known to be present or where positive signs of bat use have been found), a Habitats Regulations licence from Natural Resources Wales must be obtained.

Example of the 'stake and pleach' style of hedge laying:

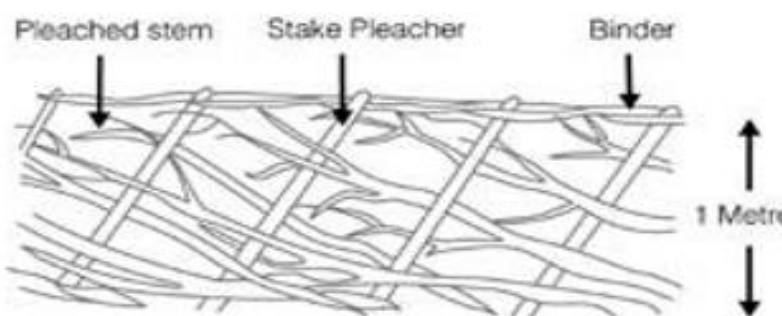

Cross Drains

Item Code: D035

Payment Rate: £82.20

This technical note describes the minimum standard of work required in order to receive payments for 'Cross Drains'. Any variation must be approved by the Welsh Government prior to starting the work.

The purpose of a cross drain is to help separate clean and dirty water on and around farmyards and tracks. Many streams and rivers in Wales are affected by pollution from agricultural runoff, impacting on biodiversity, fisheries and drinking water quality. Preventing clean water from diluting dirty water at farmyard level means that clean water can be captured for later use, and dirty water remains at more manageable quantities to be properly captured and dealt with appropriately.

Cross drains can be used to intercept clean water from clean tracks and yards upslope of the dirty track/yard areas. This clean water can be diverted into an existing ditch, swale, or sediment trap.

Alternatively, cross drains can be used to intercept foul water downslope of yards/ tracks. This foul water must be diverted into an appropriate slurry store. The open channel of the cross drain is easy to clear of accumulated silt and debris. Foul water must not be diverted into watercourses, drains or onto land.

If you are installing cross drains in farmyards to intercept clean water, you should consider whether you also need to apply for Option 910 Rainwater Goods – Guttering and Option 911 Rainwater Goods – Downpipes.

You can apply for multiple cross drains to span the whole width of wider tracks/yard areas or to install multiple tiers of cross drains across tracks carrying large volumes of water horizontally.

You must adhere to the following:

- Install purposely constructed cross drains, which can be cleared of debris and which can support slow moving heavy machinery.
- Ensure that all cross drains consist of new materials.
- Concrete work should be carried out in accordance with the relevant British Standards BS 8000 and BS 8500, as amended.
- Ensure that clean water from the cross drain is directed to a stable drainage outlet such as a ditch, swale or sediment trap.
- Ensure that foul water is discharged into an appropriate slurry store.

Requirements and guidance in addition to the specifications above:

- Ensure that you have the appropriate Flood Risk Activity Permit if you are planting or fencing near a main river, flood plain or flood defence structure. Alternatively, ensure you have the appropriate Ordinary Water Course Consent if you are carrying out works near an ordinary water course. What may be considered a ditch may be an ordinary watercourse, so consent may be required. As such, the permit/consent (or confirmation that a permit/consent is not needed) should be retained and made available on request. See Terms and Conditions for more details.

How to install a cross drain – best practice

The work will include the purchase and installation of a polychannel drainage system with grating. The channel once installed should be able to support the weight of slow moving heavy machinery, and can easily be cleared of accumulated silt and debris.

- Excavate a trench across the width of the track or along part of the farm yard, allowing sufficient depth and width for the concrete bed and surround.
- Make sure the outlet of the trench runs into a suitable ditch or swale.
- Slope the bed of the trench towards the outlet, following the depth of the proposed channel.
- Ensure that any arrows on the side of the channel point towards the outlet i.e. in the direction of flow.
- Set levels and lay out the channels alongside the trench, always starting at the outlet point.
- Pour bedding – begin at the outlet position, a good quality concrete bedding should be poured into the trench.
- Working away from the outlet, lower the channels into position following the manufactures instructions.
- Check alignment of channel.
- The grating should be loosely laid and wrapped in plastic, spanning the channel joints to ensure a clean final installation.
- The concrete surround can now be poured into the trench, taking care not to disturb the line of the run. This should finish 3mm above the channel and grating top surface.
- Once the concrete has set, lift out gratings and remove the protective plastic.
- To support heavy slow moving machinery a minimum concrete bed and surround of 200mm is required, unless specified otherwise with polychannel installation instructions.

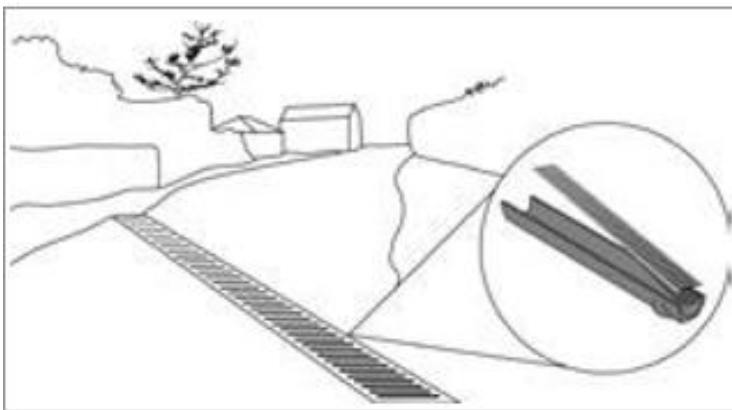

Kerbing

Item code: D036

Payment Rate: £39.78

This technical note describes the minimum standard of work required in order to receive payments for 'Kerbing'. Any variation must be approved by the Welsh Government prior to starting the work.

What is the purpose of this activity?

The purpose of installing kerbs on and around farm yards and alongside tracks is to help separate clean and dirty water. Many streams and rivers in Wales are affected by pollution from agricultural run-off, impacting on biodiversity, fisheries and drinking water quality.

Kerbs can be used to divert dirty water away from on-yard gullies or other areas where it may contribute to run-off and potential pollution.

The dirty water can then be channelled into an appropriate store or slurry store.

Alternatively, kerbs can be used to divert clean water away from dirty track/yard areas. Preventing clean water from diluting dirty water at farm yard level means that clean water can be captured for later use, and dirty water remains at more manageable quantities to be appropriately captured in slurry stores and dealt with properly.

If you are installing kerbs in farmyards to intercept clean water, you should consider whether you also need to apply for Option 910 Rainwater Goods – Guttering and Option 911 Rainwater Goods – Downpipes.

You must adhere to the following:

- Install kerbing with new kerbstones measuring 900mm x 255mm x 125mm (half battered)
- Concrete work should be carried out in accordance with the relevant British Standards BS 8000 and BS 8500, as amended.
- Ensure that clean water from the kerbing is directed to a stable drainage outlet such as a ditch, swale or sediment trap.
- Ensure that foul water is discharged into an appropriate slurry store.

Requirements and guidance in addition to the specifications above:

- Ensure that you have the appropriate Flood Risk Activity Permit if you are planting or fencing near a main river, flood plain or flood defence structure. Alternatively, ensure you have the appropriate Ordinary Water Course Consent if you are carrying out works near an ordinary watercourse. What may be considered a ditch may be an ordinary watercourse, so consent may be required. As such, the permit/consent or confirmation a permit/consent is not needed, should be retained and made available on request. See Terms and Conditions for more details.

Kerbing – best practice

- Kerbing is likely to be more stable if a trench is excavated in the existing track to a minimum depth of 300mm.
- Fill with concrete and key in pre-cast concrete kerb stones protruding from the surface.
- Tamper the concrete on the outer side to the top edge of the kerb stone.
- Leave concrete on the inner side (the side that will divert the water) flat, below the top of the kerbstone.

Sleeping Policemen

Item Code: D037

Payment Rate: £36.36

This technical note describes the minimum standard of work required in order to receive payments for 'Sleeping Policemen'. Any variation must be approved by the Welsh Government prior to starting the work.

What is the purpose of this activity?

The purpose of a sleeping policeman is to help separate clean and dirty water on and around farmyards and tracks. Many streams and rivers in Wales are affected by pollution from agricultural run-off, impacting on biodiversity, fisheries and drinking water quality.

Preventing clean water from diluting dirty water at farm yard level means that clean water can be captured for later use, and dirty water remains at more manageable quantities to be appropriately captured in slurry stores and dealt with properly.

Sleeping policemen can be used to intercept clean water from clean tracks and yards upslope of the dirty track/yard areas.

Alternatively, they can be used to intercept foul water downslope of yards/tracks. This foul water must be diverted into an appropriate store or slurry store.

Installing sleeping policemen across farm tracks can also intercept and divert surface run-off, reducing flow rates at down slope locations and therefore helping to prevent erosion on farm track surfaces. By taking action to slow run-off you can reduce water damage to tracks, minimise soil erosion and reduce the risk of water pollution.

If you are installing sleeping policemen in farmyards to intercept clean water, you should consider whether you also need to apply for Option - Rainwater Goods – Guttering and Option - Rainwater Goods – Downpipes.

You must adhere to the following:

- Create sleeping policemen to a height of at least 150 mm above track level, which can support slow moving heavy machinery.
- Concrete work should be carried out in accordance with the relevant British Standards BS 8000 and BS 8500, as amended.
- Ensure that clean water from the sleeping policemen is directed to a stable drainage outlet such as a ditch, swale or sediment trap.
- Ensure that foul water is discharged into an appropriate slurry store.

Requirements and guidance in addition to the specifications above:

- Ensure that you have the appropriate Flood Risk Activity Permit if you are planting or fencing near a main river, flood plain or flood defence structure. Alternatively, ensure you have the appropriate Ordinary Water Course Consent if you are carrying out works near an ordinary water course. What may be considered a ditch may be an ordinary watercourse, so consent may be required. As such, the permit/consent (or confirmation

that a permit/consent is not needed) should be retained and made available on request. See Terms and Conditions for more details.

- Sleeping policemen are likely to be more stable if a trench is excavated in the existing track to a minimum depth of 100mm, and then key concrete into the trench and up to a height of at least 150mm.

Rainwater Goods (Guttering)

Item Code: D038

Payment Rate: £9.02

This technical note describes the minimum standard of work required in order to receive payments for 'Rainwater Goods – Guttering'. Any variation must be approved by the Welsh Government prior to starting the work.

What is the purpose of this activity?

The purpose of new rainwater goods is to help separate clean rain water from dirty water on and around farmyards. Many streams and rivers in Wales are affected by pollution from agricultural run-off, impacting on biodiversity, fisheries and drinking water quality. Preventing rainwater from diluting dirty water at farmyard level means that dirty water remains at more manageable quantities to be appropriately captured in slurry stores and dealt with properly.

Guttering can be used to intercept and capture rainwater from farm building roofs. This clean water can be diverted into an existing clean water drain or discharged to an existing ditch, swale, or sediment trap. Alternatively it may be captured for later on-farm use.

Payments are available for the provision and installation of new rainwater goods (guttering and downpipes), where existing ineffective or non-existent rainwater goods discharge clean water onto fouled yard areas.

This option is for existing buildings, traditional or modern, within the farmyard that currently do not have rainwater goods or which have existing rainwater goods that are beyond their serviceable life and need replacement. Non-agricultural buildings and houses are not eligible.

Rainwater goods on proposed new buildings are not eligible for a grant as they should already have rainwater goods built into the design.

Listed buildings are not eligible for this option.

You must adhere to the following:

- Use guttering, typically 150mm half round PVC guttering, and appropriate brackets. All goods must satisfy all relevant British Standards, as amended, such as BS EN 607, BS EN12200 and BS EN 1462.
- Installation work should satisfy all relevant British Standards, as amended, such as BS 5502 and BS EN1917.
- Ensure that all rainwater goods consist of new materials.

Do not:

- Install plastic rainwater goods on Listed Buildings.

Rainwater Goods – Downpipe

Item Code: D039

Payment Rate: £15.04

This technical note describes the minimum standard of work required in order to receive payments for 'Rainwater Goods – Downpipe'. Any variation must be approved by the Welsh Government prior to starting the work.

What is the purpose of this activity?

The purpose of new rainwater goods is to help separate clean rain water from dirty water on and around farm yards. Many streams and rivers in Wales are affected by pollution from agricultural run-off, impacting on biodiversity, fisheries and drinking water quality. Preventing rainwater from diluting dirty water at farm yard level means that dirty water remains at more manageable quantities to be appropriately captured in slurry stores and dealt with properly.

Downpipes can be used to intercept and capture rain water from farm building roofs.

This clean water can be diverted into an existing clean water drain or discharged to an existing ditch, swale, or sediment trap. Alternatively, it may be captured for later on-farm use.

Payments are available for the provision and installation of downpipes where existing ineffective or non-existent rainwater goods discharge clean water onto fouled yard areas.

This option is for existing buildings, traditional or modern, within the farmyard that currently do not have rainwater goods or which have existing rainwater goods that are beyond their serviceable life and need replacement. Non-agricultural buildings and houses are not eligible.

Rainwater goods on proposed new buildings are not eligible for a grant as they should already have rainwater goods built into the design.

Listed buildings are not eligible for this option.

You must adhere to the following:

- Use 110mm downpipe and brackets that satisfy all relevant British Standards, as amended, such as BS EN 607, BS EN12200 and BS EN 1462.
- Installation work should satisfy all relevant British Standards, as amended, such as BS 5502 and BS EN1917.
- Ensure that all rainwater goods consist of new materials.
- Any underground drainage works should comply with all relevant British Standards, as amended, such as BS 8000, BS EN 752 and BS EN 1610.

Do not:

- Install plastic rainwater goods on Listed Buildings.

Requirements and guidance in addition to the specifications above:

- Where rainwater goods are at risk of being damaged by livestock, suitable protection should be installed.

In-Ditch Wetland

Item Code: D040

Payment Rate: £204.90

This technical note describes the minimum standard of work required in order to receive payments for 'In-ditch Wetland'. Any variation must be approved by the Welsh Government prior to starting the work.

In-ditch wetlands are ditches that have been widened to create a broader shallower wetland area. They are designed so vegetation slows the flow of water, to increase sediment deposition from field surface runoff, field drains, and ditches.

The purpose of an in-ditch wetland is to:

- Improve water quality: In-ditch wetlands trap sediment carried in runoff from fields and farmland, which could otherwise pollute rivers and lakes downstream.
- Reduce flooding: In-ditch wetlands slow the flow of water by providing valuable space where runoff can disperse, providing storage for floodwater which helps reduce flooding downstream.
- Create a wildlife habitat: In-ditch wetlands provide additional positive benefits to the nature conservation (nesting habitat for wetland birds in particular reed buntings, reed, sedge and Cetti's warbler) and landscape value at the farm scale.

You must adhere to the following:

- Choose a location within existing man made field ditches with a low gradient, where the land on either side is within your control. These are otherwise known as Stage 1 ditches which do not have continuous flow year round. The diagram below shows a typical ditch network.
- Widen the chosen area to a minimum of 10m in length and to a maximum of 3m wide and flatten the bed.
- Create a soil bund with a pipe at the lower end of the ditch to act as an outflow. The bund should be made wider than the ditch. The top should be level and at least 50cm above the intended water line. The bund should have slightly sloping sides.
- Insert one or two pipes within the bund to act as an outflow. The pipes should be between 8 –10” in diameter, and located 30cm (12”) below the top of the bund.
- Extend the pipe beyond the bund base on the downstream side of the bund to prevent the outflow eroding the bund.

- Plant up the bed with native sedge, rush or reed species, or with willow or Alder. For reed, rush and sedge species, plant at a density of 3 plants/m².

Do not:

- Locate in-ditch wetlands on natural watercourses.
- Damage other habitats such as reed beds to create in-ditch wetlands.
- Create this option between 1 March and 31 August.

Requirements and guidance in addition to the specifications above:

- Ensure that you have the appropriate Flood Risk Activity Permit if you are planting or fencing near a main river, flood plain or flood defence structure. Alternatively, ensure you have the appropriate Ordinary Water Course Consent if you are carrying out works near an ordinary watercourse. What may be considered a ditch may be an ordinary watercourse, so consent may be required. As such, the permit/consent (or confirmation that a permit/consent is not needed) should be retained and made available on request. See Terms and Conditions for more details.
- This option must not be used on natural watercourses, due to legislation requiring fish passage to be ensured at all times.
- Carry out this activity when ground conditions are as dry as possible between September and February. Temporarily bund the water flow into this area if needed, which will improve access for excavating and planting.
- Spread the excavated material thinly over the top of the banks so as to prevent weeds such as common nettle, creeping thistle etc., from dominating. Ensure the silt cannot run straight back into the in-ditch wetland.
- When constructing the bund, remove topsoil and scarify the subsoil to improve the seal between the dam and the ground surface. Build the bund slowly in layers 15cm thick and compact each layer in turn.
- Take care during completion of the activity to ensure no sediment laden water is allowed to enter the receiving watercourse.
- Do not plant with willow or alder if sedimentation is likely to be high.
- Plant up the bed with plant species already found in the local area. Do not collect protected plant species, or collect from a Site of Special Scientific Interest (SSSI). This is in line with Cross Compliance Regulations.
- For willow species plant at a density of 1 plant per m² and for alder species at 2m² spacing.
- Coppice willow and alder species every 3-5 years. Reed, rush and sedges plants should be cut every other year to prevent them from dominating the wetland. Cut in early spring before bird nesting to provide maximum roosting cover in the winter.
- This activity should be sited and managed to ensure no risk of flooding results.

In-ditch wetland (aerial view)

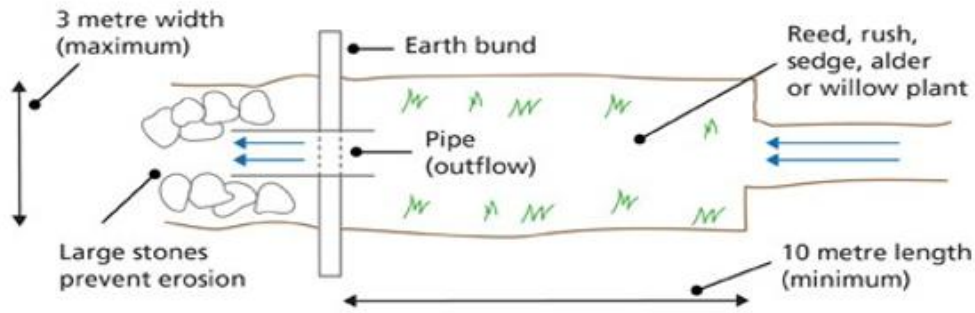

In-ditch wetland (x-sectional view of earth bund)

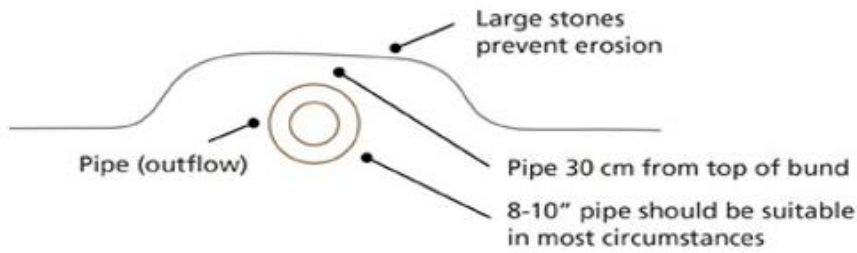

Watercourse stages

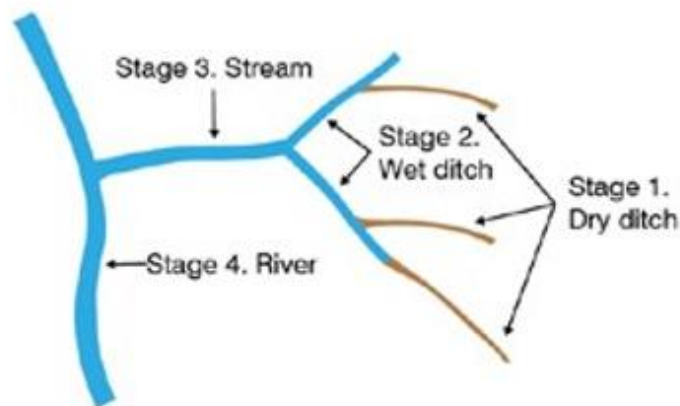

Soft Engineering of River Banks

Item Code: D041

Payment Rate: £81.30

This technical note describes the minimum standard of work required in order to receive payments for 'Soft Engineering of River Banks'. Any variation must be approved by the Welsh Government prior to starting the work.

What is the purpose of this activity?

Riverbanks and the riparian zones immediately behind the bank top provide valuable wildlife habitat that can support a wide range of plant and animal species. They supply shelter, food and shade and protect the river from surface runoff. Riverside vegetation and the fibrous roots of that

vegetation help to maintain the stability of the bank, and prevent downstream flooding and further erosion by reducing the river's energy.

Naturally occurring erosion of riverbanks is an important river process that reduces the energy of river flows, redistributes sediment and provides nesting locations for birds such as sand martins and kingfishers. However, human activity can increase erosion. Livestock, for example, can destabilise banks through poaching and removing vegetation, while river engineering such as gravel removal, re-profiling and hard engineering works can increase the energy of the river and increase erosion.

Soft engineering (or bio-engineering) measures utilise natural processes to reduce future negative erosion whilst allowing the area to re-vegetate and stabilise. Compared with traditional 'hard' defences (e.g. rock, concrete, gabions) woody materials create more diverse habitats for plants, invertebrates and fish. Soft engineering measures are more resilient in the long term as the materials used are flexible, so they absorb and dissipate the erosive forces rather than simply reflect energy as per hard defences. Furthermore, areas of soft engineering can be coppiced in the future to supply a ready and freely available source of materials for use on neighbouring sites.

River engineering is difficult and it is worth obtaining expert advice on the most appropriate techniques. Your local rivers trust, the River Restoration Centre (www.therrc.co.uk/) or Natural Resources Wales may all be able to recommend the most appropriate approach, or supply further guidance.

You must adhere to the following:

- Install the correct quantity of river bank soft engineering on damaged or eroding watercourses, using sufficient stakes and withies to ensure a stable and robust structure. Guidelines for choosing and constructing the correct style of soft engineering are laid out below.

Do not:

- Graze the area of soft engineering.
- Use soft engineering as a retaining structure.
- Allow soft engineering to block water flow in small river channels.

Requirements and guidance in addition to the specifications above:

- Ensure that you have the appropriate Flood Risk Activity Permit if you are planting or fencing near a main river, flood plain or flood defence structure. Alternatively, ensure you have the appropriate Ordinary Water Course Consent if you are carrying out works near an ordinary water course. What may be considered a ditch may be an ordinary watercourse, so consent may be required. As such, the permit/consent (or confirmation that a permit/consent is not needed) should be retained and made available on request. See Terms and Conditions for more details.
- There are different bank protection techniques using live and dead woody material that may be suitable depending on the site. Select which of these techniques (or combination) is suitable for your site, and follow the guidance below.

Willow spiling: is a traditional technique used to stabilise eroding banks.

It involves weaving live willow rods (withies) between vertical live willow stakes set into the affected bank at regular intervals to create a living fence like structure, or 'revetment'. The space behind the willow fence to the existing bank is then filled with soil to provide an area for the willow roots to grow.

There are 2 types of spiling – producing a tighter weave for revetments below water level, and a looser weave for revetments above water level.

- Hurdles can be used instead of spiling where the nature of the site makes it dangerous or unsuitable to create spiling in situ.
- Faggoting (brushwood or brushings tied in bundles) can be used by themselves or in conjunction with spiling or hurdles depending on the nature of the site. Faggots (or fascines) are bundles of willow or brushwood, bound together and used for various stabilisation and revetment purposes. Faggots slow the flow of moving water and trap silt and sediment, and the buried branches then help consolidate the sediments against renewed erosion.
- Do not use in locations where other habitat is present that could be harmed by increased willow cover e.g. fens, wet unimproved grassland, wet heath, rhos pasture, bogs, or areas where you know ground nesting birds such as lapwing or curlew nest.

Spiling

1a: A tight weave spiling for revetments below water level.

- Installing revetments below water level may require specialist contractors.
- Use vertical stakes of 65-100mm (2.5-4") diameter for spilings up to 600mm high.

For spilings up to 900mm (3') high, thicker stakes of 100-130mm (4-5") diameter will be needed.

- Use crack willow (*Salix fragilis*) or white willow (*Salix alba*) to produce the best material for stakes.
- Knock the stakes in vertically along the line of the revetment, about half a metre apart and so that two-thirds of the finished height of the stake is below soil level, then cut the tops to the finished height.
- Use withies which have a butt diameter of 10-20mm (0.25-0.75") and be of a length equivalent to five times the stake spacing, to give a close, tight weave.
- Use osier (*Salix viminalis*), goat willow (*Salix caprea*) or grey willow (*Salix cinerea*) to produce the best material for withies.
- Weave the withies between the stakes, alternating the direction of the butt ends and tucking both ends in so they don't protrude. At the end of each length of revetment, the spiling should be run into the bank so that the last two to three stakes are completely buried after backfilling.
- Backfill to the required bank profile with soil once stakes and withies are securely placed.
- Place faggots (see below) behind the spiling where there is a risk of backfill washing out.
- Undertake spiling between November and March (when average temperatures are below 2°C).
- Use freshly cut willow for the vertical stakes and horizontal withies, so that they will sprout and produce a living revetment.

- Pollarding or coppicing of bank side willow, or pruning of earlier spiling, will produce suitable material of the sizes mentioned above.
- Where willow is unavailable, alder can be used as an alternative. Willow or alder should be of local origin where possible.
- Stakes and withies can be stored between November and February for up to three weeks, provided they are kept cool and damp. Outside this season, they are best used within 48 hours of cutting and are always best having been soaked immediately before use.
- Where there is a risk of vandalism wire down the top withies and secure to the stake with a staple.
- It is advisable to exclude stock for at least 2 or 3 years until the willow structures have established and the ground has become stabilised.

Example of tight weave spiling below water level

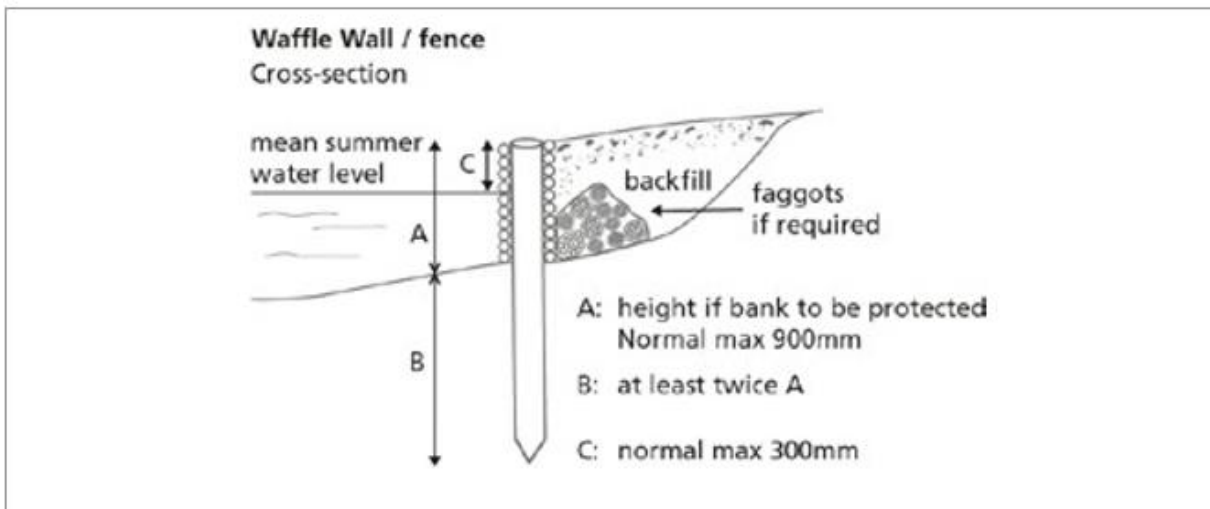

Waffle Wall / fence
Face View

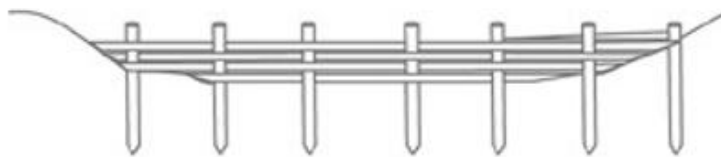

1b: A looser weave spiling for revetments above water level

- Insert the stakes as described for 1a above.
- Start weaving the withies between the second and third stake from one end. Push the end of the withy into the ground, and then weave between the stakes towards the end stake. Push the next withy into the ground and weave it alongside the first. The withies will root at the ends.
- Continue weaving along the stakes, until the withies reach the top of the stakes.
- Ensure the top withies are tightly woven to secure the spiling.
- Where there is a risk of vandalism wire along the top or down through the spiling.

- It is advisable to exclude stock for at least 2 or 3 years until the willow structures have established and the ground has become stabilised.

Example of tight weave spiling below water level

Looser weave Waffle Wall / fence

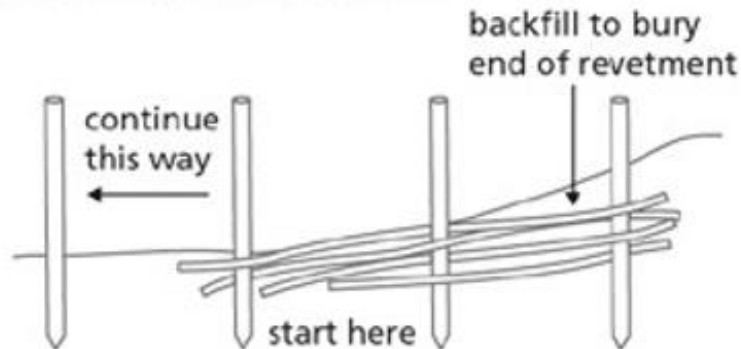

2. Hurdles

- Construct hurdles from hazel and willow.
- Construct hurdles to a maximum size that can be safely moved into position. Typically, a hurdle is 1.8m (6') long by 1m (3.5') high.
- Construct the hurdle from a series of upright 'zales' which should be at least 90cm tall, and no more than 25cm (10") apart, interwoven with tightly packed series of horizontal rods. A typical construction method is described below.
- Use two 1.5m (5') stakes for each hurdle, knock the stakes into position on the outer side of the revetment and wire the hurdles to the stakes to hold them in place.
- Backfill the hurdle with faggots and/or spoil.
- Construct hurdles off-site if working conditions at the bankside are difficult, however, ensure the hurdles are of a size and weight that you are able to transport. The structure should be strong enough to survive handling and positioning.
- If possible, use split hazel for the uprights or 'zales', as they hold the laterals better than round poles. Willow is also acceptable and is more suitable for the horizontal weaving.
- Push 900mm (3') 'zales' about 300mm (1') into the ground, evenly spaced in a straight line as shown.
- Weave hazel or willow rods between the 'zales', tucking each end back under itself to lock the wands in place. Force the wands down with your foot to give a tight weave. It may be necessary to wire or tie the top wands to discourage vandalism.
- Lift out the sections for transport to the site. Place the hurdles in position, overlapping as shown, below, and drive them in as far as the lower wands.

Waffle fence / hurdles

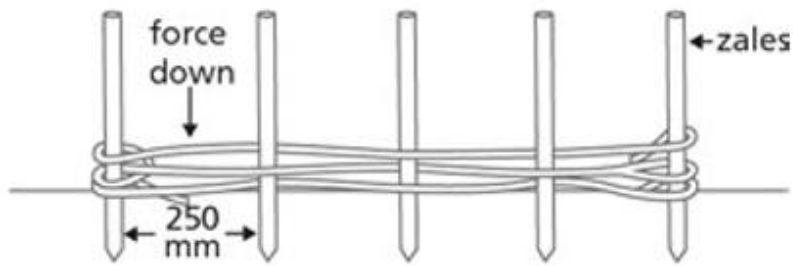

3. Faggots

- Construct faggots to a maximum size that can be safely moved by two people. Typically, the traditional size is about 2m (7') long and 300mm (1') diameter, bound at three points.
- Bind the faggots with twisted willow, baler twine or wire.
- Secure the positioned faggots by attaching them to stakes knocked well down into the bank. Secure the faggot to the stake with wire. The faggots should be positioned as shown in the diagrams below, or placed behind hurdles, or spiling revetments. Consider using live willow cut in the winter as this is likely to root and grow. Growing willows are beneficial as their roots help to stabilise bank material and their shoots provide protection against bank scour.
- To stabilise a bank the faggots can be laid in a single or double row, secured by stakes and wire as shown. As necessary, another layer can be added cross-wise.
- Smaller faggots, of about 100mm diameter can be bound together to form 'mattresses', for laying on banks, subject to boat wash or strong flows. A large faggot at the base absorbs some of the wave energy.

Faggots (Willow bundles) Aerial Plan

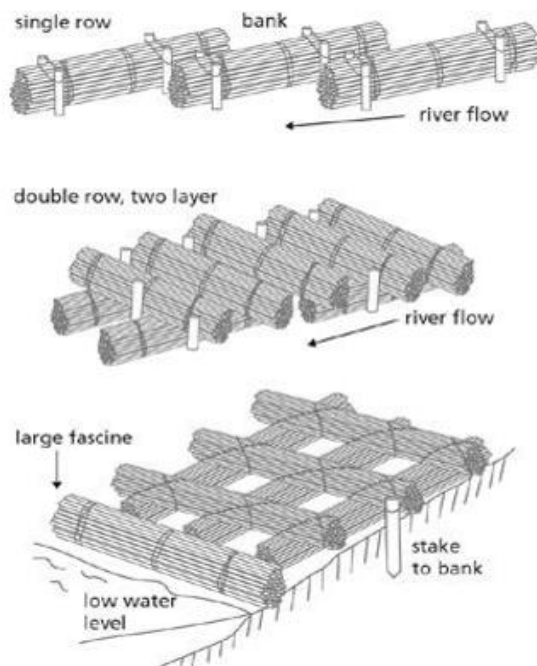
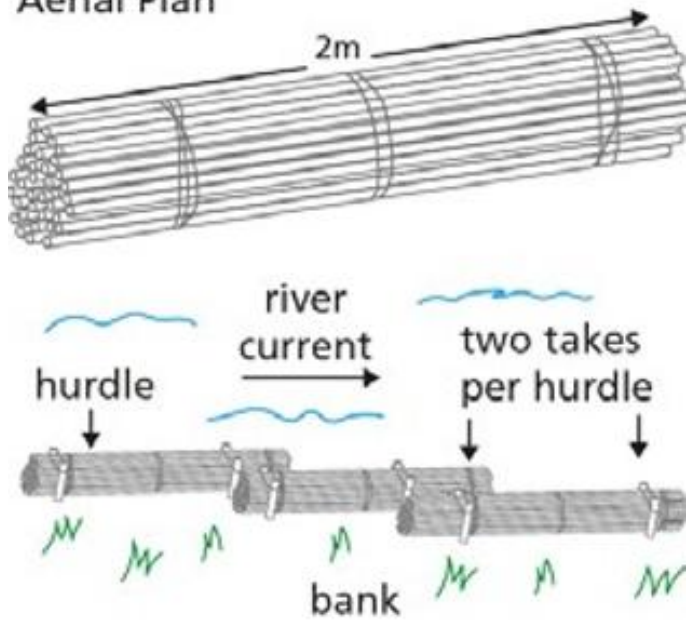

Pond Restoration

Item Code: D042

Payment Rate: £7.88

This technical note describes the minimum standard of work required in order to receive payments for 'Pond Restoration'. Any variation must be approved by the Welsh Government prior to starting the work.

Ponds and other small water bodies are important for freshwater biodiversity and storing water. Areas with large numbers of ponds can be particularly important because they provide habitats for a wider range of plants and animals.

Ponds are particularly vulnerable to nutrient enrichment, siltation and domination by invasive plants. Causes of this include nutrient-rich runoff from fields and farmyards, high stock densities causing overgrazing and poaching of margins, feeding of waterfowl and stocking with fish. Invasive species may spread naturally or by deliberate or accidental introduction.

There are many different kinds of 'good' pond and you should not try to make all ponds on your farm look the same. A range of different sorts of ponds provide the widest range of habitats and can support some of our most threatened animals and plants.

If you have more than one pond, managing vegetation and silt on a staggered rotation of about 10 years will provide a range of different habitats.

Nevertheless, there are some general rules. Good ponds tend to have:

- Extensive areas of shallow water;
- Not too many fish or water birds;
- Clear water;
- A range of different water plants with no invasive species;
- Lightly grazed margins with no more than about half the pond shaded.

Ponds do not need to contain water all year, and some rare animals and plants need temporary ponds where predators cannot survive. However, water levels must be allowed to vary naturally, but the pond should contain water for at least 6 months per year.

Do not introduce animals or plants to your pond, especially from a garden pond, or a garden centre. Native pond species are good dispersers, and will arrive in healthy ponds by themselves.

The following types of pond are not suitable for this INRS pond restoration option:

- A significant inflow or outflow 1m, or more, wide. This is because watercourses often carry silt and/or pollutants.
- Significant water quality problems that cannot be addressed by the restoration measures of this option. If there is serious pollution, disposal of material can be problematic and restoration is much less likely to be effective.
- Constructed wetlands or other traps for dirty water. These ponds are designed to trap pollution.
- Ponds with large numbers of fish or ducks make poor habitat for wildlife due to heavy predation.
- Ornamental ponds or ponds with non-native invasive species. These ponds make poor habitat for wildlife and restoration activities may encourage spread of invasive animals and plants.

You must adhere to the following:

- Maintain a buffer strip of long vegetation between the pond and any upslope intensively managed land.
- Ensure you have prevented any sources of pollution and nutrients from reaching the pond including any run offs that may contain fertilisers, slurries, manures, silage effluent or other nutrients.
- Remove any scrap, redundant fencing or any other rubbish such as plastic wrap.
- Spread any removed silt on adjacent land in compliance with waste exemption U10 and waste exemption D1.
- Exclude all stock from accessing the pond by ensuring there is at least 1 metre between the fence and water's edge. Stock access can be permitted to 10% of the pond area.
- Create a mixed pattern of trees and shrubs around the pond by coppicing some scrub to allow more light onto the surface of the water and reducing leaf drop into the pond.

Do not:

- Restore ponds between March and August.
- Dredge more than one third of the surface area of a pond at any time.
- Allow dredged silt to run back into the pond. Dredged material must be spread down slope from the pond, but not where it may run into adjacent watercourses.
- Create islands in the pond.
- Allow stock drinking access for more than 10% of the pond.
- Remove any old trees from around the pond as they may contain bird nesting sites, bat roosts and rare mosses and lichens.

Requirements and guidance in addition to the specifications above:

- Ensure that you have the appropriate Flood Risk Activity Permit if you are planting or fencing near a main river, flood plain or flood defence structure. Alternatively, ensure you have the appropriate Ordinary Water Course Consent if you are carrying out works near an ordinary watercourse. What may be considered a ditch may be an ordinary watercourse, so consent may be required. As such, the permit/consent (or confirmation that a permit/consent is not needed) should be retained and made available on request. See General Rules for more details.
- Ensure that you apply for a European Protected Species licence from Natural Resources Wales (NRW) if you have Great Crested Newts in or close to the pond. This should not normally prevent restoration works since these will generally be beneficial to newts, but it is important to include sufficient time for the application process.
- This INRS project includes dredging a maximum of one third of the pond. The remaining two thirds should be dredged in rotation in future years, but this is not included within this INRS project. This ensures that invertebrate populations are not totally removed.
- Do not damage ponds that are considered existing habitat such as reed beds, fens or ponds on unenclosed land. It may be possible to obtain grants for pond restoration on existing habitat but this will require further discussion and/or consultation with Natural Resources Wales to ensure that no damage is being done to a Section 7 Habitat or Species, protected species or feature of a Protected Site.

- To minimise impacts on wildlife, restore ponds between September and January. Aim to do work in dry weather when pond levels are low and machinery will run less risk of poaching the soil.
- Removing silt from the pond is appropriate when:
 - No submerged aquatic plants can be seen, either because the water is very turbid or because the bed is clearly covered by a deep, loose layer of silt or leaf litter.
 - The sediment is completely black and smells of rotten eggs, and large bubbles of gas can be seen bubbling up occasionally.
- If removing from the pond, scrape out loose sediment until a firmer layer such as clay, marl or other firmer sediment is reached. Take care not to break the natural seal of the pond bed.
- Do not create artificial islands as they encourage gulls and waterfowl, resulting in poor water quality.
- If there is a danger of leaching from adjacent intensively managed fields, consider establishing a strip of long vegetation adjacent to the pond which can act as a buffer strip.
- The Million Ponds website also has useful information regarding restoring ponds for other protected species such as Great Crested Newts and Water Vole:
<https://freshwaterhabitats.org.uk/projects/million-ponds/>
- More information on ghost ponds can be found at <http://ghostponds.wordpress.com/>
- More information on waste exemption U10 (<https://www.gov.uk/guidance/waste-exemption-u10-spreading-waste-to-benefit-agricultural-land>)
- More information on waste exemption (<https://www.gov.uk/guidance/waste-exemptions-disposing-of-waste>) D1 and registering waste exemptions.

Diagram – Cross Section of Pond

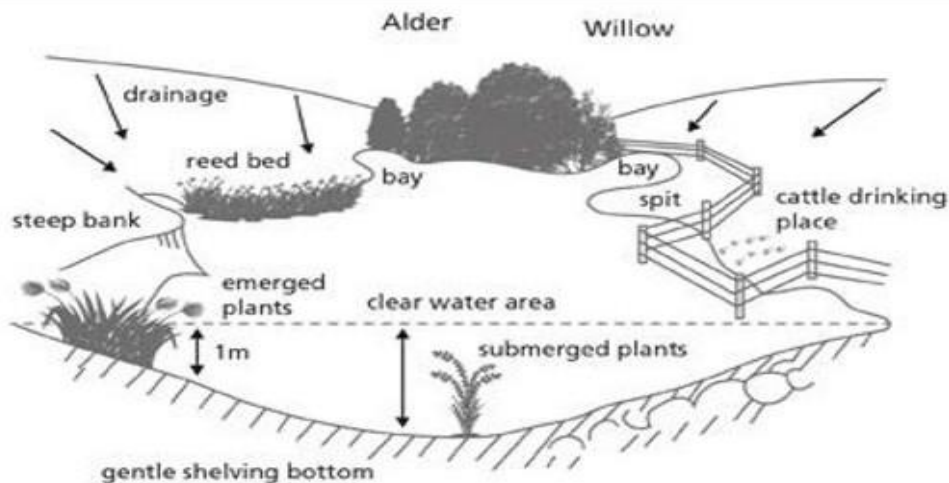

New Hedge Planting for Pollinators

Item Code: D043

Payment Rate: £9.39

This technical note describes the minimum standard of work required in order to receive payments for 'New Hedge Planting'.

Any variation must be approved by the Welsh Government prior to starting the work.

You must adhere to the following:

- Plant native trees and shrubs in a mix of at least three hedging species. At least 90% of the planting mix must comprise of the following species; blackthorn, hawthorn, crab apple, wild plum or wild cherry. No one component of the mix should comprise more than 75% of the total.
- Plant hedge plants that are at least 45-60cm high which should have a strong leader shoot.
- Plant new hedgerows at a density of 7 plants per metre in a staggered double row, with 20cm between each row.
- Prevent new plants from being killed by shading out from excessive weed growth.
- Protect newly planted hedges from livestock.
- Replace any dead plants.
- Ensure there is at least 1m between new planting and protective fencing.
- Ensure that the hedge is able to grow to a 3m width. There must be a gap of at least 3m between double fences.

Do not:

- Plant any ash trees as part of any planting mix due to ash dieback disease (*Hymenoscyphus fraxineus*).
- Cause damage to any existing historic hedge banks during ground preparation, planting or fencing.
- Use trees and shrubs as strainers or fencing posts, or use them to support fencing wire, staples or netting.

Requirements and guidance in addition to the specifications above:

- Ensure that you have the appropriate Flood Risk Activity Permit if you are planting or fencing near a main river, flood plain or flood defence structure. Alternatively, ensure you have the appropriate Ordinary Water Course Consent if you are carrying out works near an ordinary water course. What may be considered a ditch may be an ordinary watercourse, so consent may be required. As such, the permit/consent, or confirmation that a permit/consent is not needed, should be retained and made available on request.
- If undertaking any spraying as part of this activity ensure you have obtained any consents that may be necessary.
- Where INRS activities include the installation of access furniture such as stiles or gates on a Public Right of Way, it is your responsibility to ensure you obtain approval under Section 147 of the Highways Act, 1980, from the appropriate Highway Authority.
- Ensure the best chances of survival, by planting new hedgerow plants in the winter months from November to March. Keep root balls damp during planting, and water liberally in dry spells until established.
- Select plants with well-developed root systems. Plants which are 3 – 4 years old are recommended

- Prepare the ground for planting by either rotovating, ploughing or digging over during the previous summer. Avoid damaging historic banks during ground preparation by digging manually.
- You may incorporate some well-rotted manure if planting hedge plants on poor soils.
- Plant locally common native species where possible. Plants should be derived from locally collected seed or cuttings if possible as these are likely to survive better and support more species of native wildlife.
- Control weeds by using a mulch of wood chippings or by securely pegging down a 500-gauge black polythene sheet, 1-2m wide at the base of the transplants. Chemical control of grasses, thistles, docks and ragwort may be undertaken.
- Any chemical used must have a label recommendation for use on the listed species and for the intended method of application. All manufacturers label recommendations regarding application of the herbicide must be strictly adhered to.
- Encourage new growth by trimming the transplant back.
- Establish at least 1 – 2 hedgerow trees per 100m. Either plant new saplings (at least 1m tall), or identify existing plants that can develop into trees. It is sensible to tag the tree to avoid accidental damage when hedge trimming. Choose native tree species that grow well in local hedges, as they will contribute to an attractive landscape and can increase the wildlife value of the hedge.
- Spiral guards can be used to protect the hedge from rabbits, although in certain areas rabbit fencing may be a more effective deterrent.

Earth Bank Restoration

Item Code: D044

Payment Rate: £10.89

This technical note describes the minimum standard of work required in order to receive payments for 'Earth Bank Restoration'.

Any variation from the standards set out must be approved by the Welsh Government prior to starting the work.

Earth banks are an important landscape feature which can be an important record of historical land use, as well as important features for biodiversity and stock shelter.

They may or may not have hedgerows planted on top. Old hedges and banks may not follow straight lines, a factor that contributes to both their landscape and historic importance.

Prolonged bad weather, trampling by livestock and burrowing by rabbits can all cause damage to the bank.

You must adhere to the following:

- Restore degraded earth banks so that the height and the line of the restored bank follow that of the existing feature. Best practice guidelines for restoring earth banks are described below.

- Ensure that grazing animals do not damage restored banks.
- Fill any trenches or pits from which soil has been taken with loose earth or discarded turfs. The area on both sides of the newly restored bank should be left level and tidy.

Requirements and guidance in addition to the specifications above:

- Where INRS activities include the installation of access furniture such as stiles or gates on a Public Right of Way, it is your responsibility to ensure you obtain approval under Section 147 of the Highways Act, 1980, from the appropriate Highway Authority.
- Ideally, turfs cut from the adjacent field should be used to re-surface the earth bank, however, if natural regeneration is taking place when the claim is submitted and geo-tagged 'after' photos show this, that would be acceptable.
- Excavate all loose turf and earth from the area to be repaired until a firm foundation is available. Retain loose soil for use during rebuilding. The cleaned area should slope inwards slightly as well as being wider at the top than the bottom (v-shaped or trapezoid in face view), as this will allow the repair work to key into the existing bank on both sides. Tamp down the newly formed foundation with a suitable hand tool to achieve as firm a surface as possible. (See diagram 1).
- Replacement turfs, where used, should be cut from the field at the foot of the bank. Smaller turfs are more likely to knit together once they have been placed in their new position.
- Turfs less than 30cm square are easier to handle and turfs cut on a slant will knit together more easily than those with squared edges (See diagram 1).
- Proper backing for the new turfs must be provided before they are placed in position. Use the previously retained earth together with any loose soil left in the trench, from which the newly cut turfs were removed. Keep the backing well filled and slightly above the level of each course of turfs as they are put in place. The backing should be keyed into the old bank and tamped down firmly to reduce the risk that heavy rain or a severe frost will cause the new work to slip away. (See diagram 2).
- Best practice is to place turfs in a series of layers or courses. Break the joints between alternate courses as in brickwork. Turfs should slope inwards slightly with each turf tamped well down to eliminate as far as possible the visible joints between the courses. Set each course very slightly back from the course below by about 1-2.5cm. Together with the inward slope this will allow for some movement outwards when tamping down, and for rainwater to run into the root areas of each turf. (See diagrams 1 & 2).
- Finish with loose soil on the top of the bank, to just above the level of the turf to allow for settlement. The batter (the slope back from the vertical) may be varied according to the site and conditions, but the base of the bank will normally be some 45–60cm wider than the top.
- Infilling any large gaps with well compacted soil before replacing the surface turf will help prevent further erosion taking place. The short turf covering a well-maintained earth bank helps to maintain the shape of the structure.

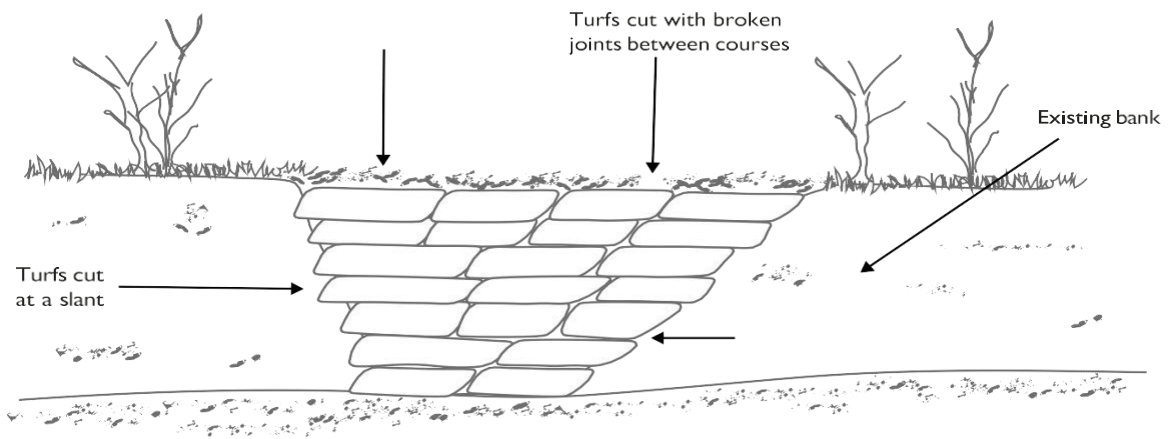

Cross Section of Earth Bank (2)

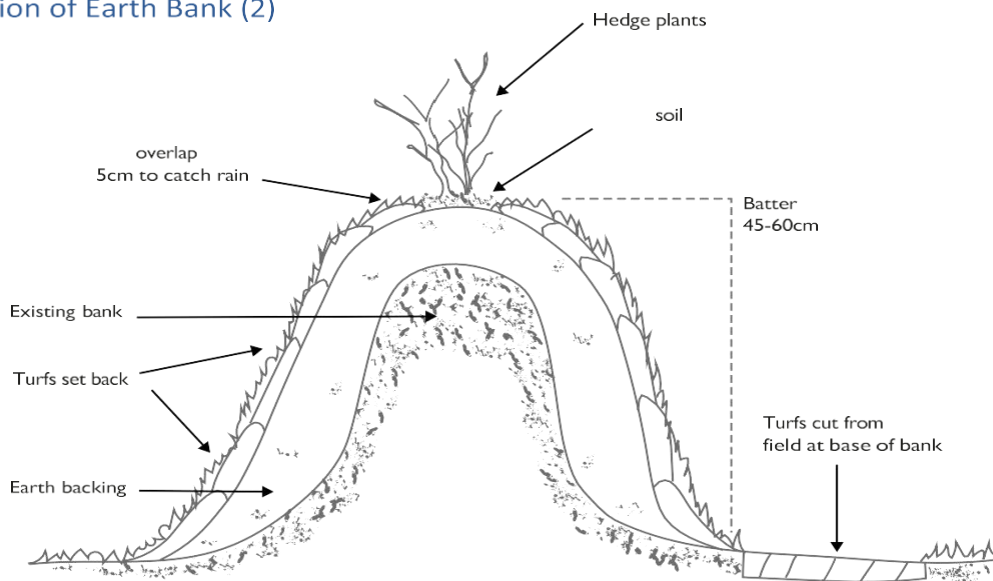

Stone-Faced Earth Bank Restoration

Item Code: D045

Payment Rate: £28.10

This technical note describes the minimum standard required in order to receive payments for 'Stone Faced Earth Banks Restoration'. Any variation from the standards set out must be approved by the Welsh Government prior to starting the work.

Stone faced earth banks are an important landscape feature which can be an important record of historical land use, as well as important features for biodiversity and stock shelter. They may or may not have hedgerows planted on top. Old hedges and banks may not follow straight lines, a factor that contributes to both their landscape and historic importance. Prolonged bad weather, trampling by livestock and burrowing by rabbits can all cause damage to the stonework and the underlying bank.

You must adhere to the following:

- Restore degraded stone-faced banks so that the height and the line of the restored bank follow that of the existing feature. Best practice guidelines for restoring stone faced earth banks are described below.
- Ensure that grazing animals do not damage restored banks.
- All surplus stone and earth should be removed from site on completion and the adjacent ground returned to the original vegetation.

Requirements and guidance in addition to the specifications above:

- Where INRS activities include the installation of access furniture such as stiles or gates on a Public Right of Way, it is your responsibility to ensure you obtain approval under Section 147 of the Highways Act, 1980, from the appropriate Highway Authority.
- Local stone should be used wherever possible, but do not raid stone from inappropriate places such as old ruins or other walls.
- **Footings and Foundations** – Loose stones and earth fill must be cleared out until a good, sound earth bank is encountered. Replace the previously removed stones and earth in stages. During this work the earth infill should be allowed to settle at various stages before completion. This settling process will be sped up if it rains during rebuilding.
- Where complete restoration is specified, all of the stone facings should be removed down to the foundations and rebuilt from this level. Sound foundations or footings will consist of at least one row of the largest stones available, laid in a trench 15–20cm deep. Gaps between footings should be packed with smaller stones. The footings themselves should be at least 7.5cm wider than the base of the wall. (See diagram).
- **Batter** – Batter is the term given to the inward taper of the wall from the base to the top. If the stone facing is 70–90 cm wide at the base it should be 30–40 cm wide at the top. There must be sufficient batter to ensure a stable wall. The batter can be straight, ‘A’-shaped or a concave depending upon the local style.
- **Drainage** – Where surface water runoff is liable to endanger the stability of the wall, a 40–60cm deep drain should be installed as shown in the diagram. Pipes should be laid in the trench bottom before refilling with loose stone.
- **Mortar** – Where stone faced earth banks are built next to busy roads or picnic sites, it may be necessary to use lime mortar in places, especially between the coping stones on the top. Mortar should not be used throughout the structure as this can cause drainage problems. The external appearance should be of a dry stone wall.
- Once restored, stone-faced earth banks must be regularly maintained to prevent deterioration.

Stone Faced Earth Banks

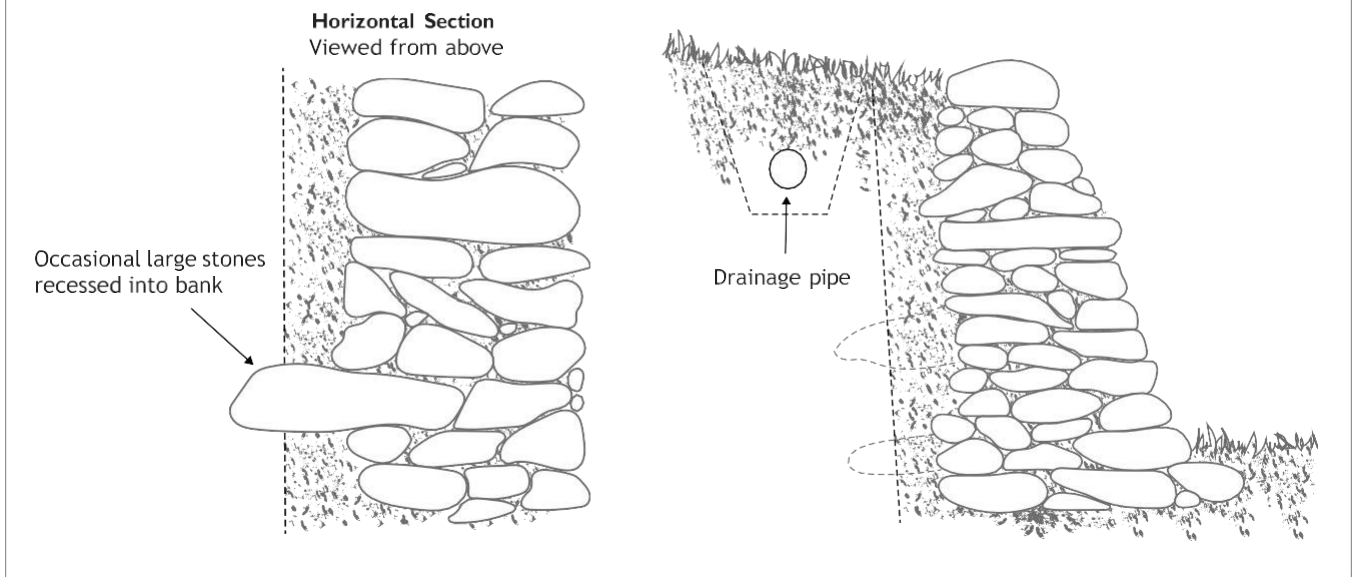

Slate Fence Restoration

Item Code: D046

Payment Rate: £28.55

This technical note describes the minimum standard of work required in order to receive payments for 'Slate Fencing Restoration of Existing'. Any variation from the standards set out must be approved by the Welsh Government prior to starting the work.

Slate fences are a feature in the landscape in areas where the slate has been quarried commercially, notably at Nantlle, Waunfawr, Llanberis and Bethesda in North Wales.

You must adhere to the following:

- Restore existing slate fences only.
- Restore the fence so that there are at least three vertical slates per metre run.
- Set slates into the ground to a sufficient depth to ensure stability.
- Ensure that the top of the slates are at least 106cm from the ground.
- Wire individual slates together by drilling the slates and using at least 3 lines of wire (top, middle and bottom of the slate fence). Two wires should be used on each line and loops twisted around the slates, as shown in the diagram below. Where slates are spaced more widely, the individual slates should be drilled and the wire strained as in a standard post and wire fence using wooden straining posts.
- All slate used to restore slate fences must match the slates in existing features.

Requirements and guidance in addition to the specifications above:

- Where INRS activities include the installation of access furniture such as stiles or gates on a Public Right of Way, it is your responsibility to ensure you obtain approval under Section 147 of the Highways Act, 1980, from the appropriate Highway Authority.
- Best practice is to set slates at least 60cm into the ground to ensure stability.

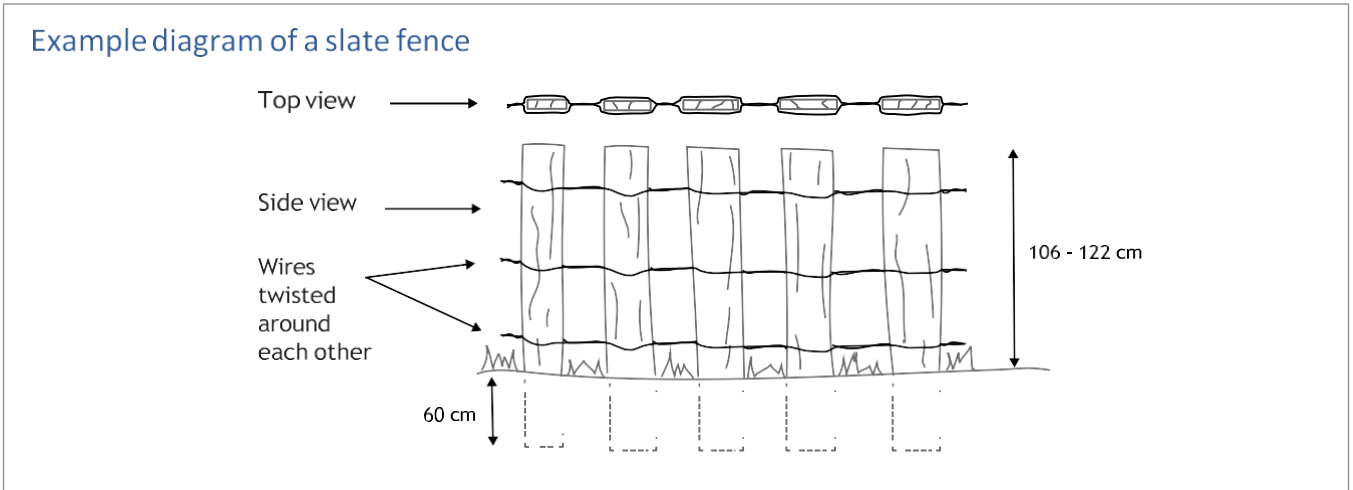

Top Wiring on Stone Walls

Item Code: D047

Payment Rate: £2.49

This technical note describes the minimum standard of work required in order to receive payments for 'Top Wiring on Stone Walls'.

Any variation from the standards set out must be approved by the Welsh Government prior to starting the work.

You must adhere to the following:

- Use fencing timber comprising either hardwood or pressure treated softwood.
- Ensure that timbers, wire and galvanised staples consist of new materials.
- Use posts with at least 6.5cm top diameter. Posts must be set at centres of 3m or less. Posts should be set within the wall.
- Attach at least one line of wire (4mm gauge plain or 2.5mm two ply barbed) to the posts with galvanised staples.
- Remove any existing derelict fencing.

Do not:

- Use trees and shrubs as strainers or fencing posts, or attach wire, staples or netting to them.

Requirements and guidance in addition to the specifications above:

- Where INRS activities include the installation of access furniture such as stiles or gates on a Public Right of Way, it is your responsibility to ensure you obtain approval under Section 147 of the Highways Act, 1980, from the appropriate Highway Authority.

Fruit Trees Plus Guard and Stake

Item Code: D048

Payment Rate: £125.00

This technical note describes the minimum standard of work required in order to receive payments for planting 'Fruit Trees with a Guard and Stake'. Any variation must be approved by the Welsh Government.

In the past, nearly every farm would have grown varieties of fruit for domestic use and for marketing locally. As the trees aged, they were not replaced; the few surviving examples are a distinctive feature in the countryside and often have a high wildlife value.

The retention of old fruit trees should take priority over re-planting, as old trees are important for their biodiversity value and can be pruned to prolong their life.

You must adhere to the following:

- Use either M25 or MM111 rootstocks to give a traditional 'standard' size tree at maturity.
- Plant trees at a maximum density of 100 trees per hectare and space the trees throughout the area to be planted.
- Stake young trees and protect from grazing livestock by using a guard.
- All guards constructed from timber rails must be at least 1.2m high and set at least 1m from the tree to protect against sheep (or 1.5m to protect against cattle and horses). Each of the 4 corner posts should have a minimum diameter of 10cm x 10cm. At least 4 wooden rails with a minimum diameter of 10cm x 5cm should be fixed to the outside of the posts. Galvanised stock netting should then be fixed around the outside of the structure and held in place with galvanised staples.
- Triangular shaped enclosures are only acceptable where sheep are the sole livestock. Such enclosures must be at least 1.2m high and set at least 1m from the tree to protect against sheep. It is important to remember that as the tree grows it may be necessary to widen the guard.
- Use fencing timber comprising either hardwood or pressure treated softwood.
- Ensure that timbers, wire, netting and galvanised staples consist of new materials.

Do not:

- Use dwarfing rootstocks.

Requirements and guidance in addition to the specifications above:

- Plant a selection of trees including early and late flowering varieties, to assist with pollination and to reduce problems caused by frost or disease. The addition of a small number of plums, damsons or pears, as well as apple trees will add diversity.
- As a guide, trees should not be planted less than 6m apart.
- When constructing the guards, use a combination of vertical posts and horizontal rails to build a rigid structure. Fix wire netting around it to prevent access by livestock. The horizontal rails will prevent the posts from being loosened. A variety of stock might have access over time so the guard must be strong enough to withstand the worst case scenario. Do not try to increase the distance of the top rail from the tree by slanting the posts outwards. This will make it difficult to fix the netting securely in place.
- It is not necessary to top the enclosure with barbed wire, as this is unlikely to stop animals leaning over, and you will make it more difficult to get into the enclosure to tend the tree.
- Additional sets of rails may also be placed mid way up the posts to provide additional strength.

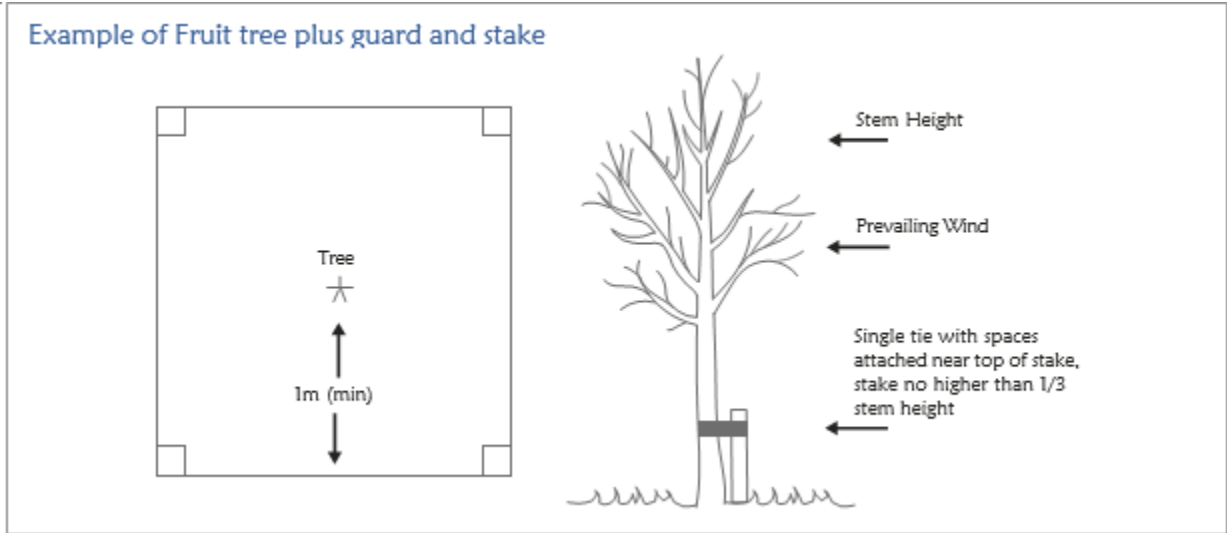

Maintenance of Gateways with Hardcore

Item Code: D049

Payment Rate: £5.98

This technical note describes the minimum standard of work required in order to receive payments for 'Maintenance of Gateways'. Any variation must be approved by the Welsh Government prior to starting the work.

What is the purpose of this activity?

Gateways and other areas which are frequently used by livestock and farm vehicles can be at increased risk of compaction and erosion. Compaction leads to poor drainage where water collects and pools.

Gateways can also act as exit points for run off from a field. Many streams and rivers in Wales are affected by pollution from agricultural runoff, which impacts on biodiversity, fisheries and drinking water quality. Installing hardcore in gateways will help reduce compaction, erosion and any resulting run off.

You must adhere to the following:

- Lay stone to a minimum depth of 200mm across the gateway and approach to create a flat even hardcore pad.
- Repair any damage or excessive wear such as that caused by harvesting or natural events to area of hardcore immediately.

Do not:

- Use concrete to set the stone in place.
- Use the hardcore pad as a location for feeders, drinking troughs or to store vehicles and machinery.

Requirements and guidance in addition to the specifications above:

- Ensure that you have the appropriate Flood Risk Activity Permit if you are planting or fencing near a main river, flood plain or flood defence structure. Alternatively, ensure you have the appropriate Ordinary Water Course Consent if you are carrying out works near an ordinary water course. What may be considered a ditch may be an ordinary watercourse, so consent may be required. As such, the permit/ consent (or confirmation that a permit/ consent is not needed) should be retained and made available on request. See Terms and Conditions for more details.

Post and Wire Fencing with Netting

Item Code: D050

Payment Rate: £8.33

This technical note describes the minimum standard of work required in order to receive payment for 'Post and Wire Fencing with Stock Netting'. Any variation must be approved by the Welsh Government prior to starting the work.

You must adhere to the following:

- Ensure that you have obtained, and adhere to any licences, consents or permissions that are needed.
- Use fencing timber comprising either hardwood or pressure treated softwood.
- Ensure that timbers, wire, netting and galvanised staples consist of new materials.
- Use straining posts that are a minimum of 12.5cm cross section and at least 2m long. Straining posts must be set into the ground at a sufficient depth to ensure stability. Straining posts must be placed at either end of the fence line and at centres of 100m or less, as well as at every horizontal or vertical change of direction.
- Attach struts at each end of the fence line and at all changes of slope and direction. Struts must have a top diameter of at least 6.5cm and must be supported to prevent them splaying outwards. Use intermediate posts that are at least 6.5cm diameter (round posts and sawn timber) and at least 1.7m long. Half round posts are acceptable provided they measure at least 6.5cm from the midpoint of the sawn side to the midpoint of the round side. Intermediate posts must be set at centres of 3m or less.
- Attach netting to posts with galvanised staples.
- Attach wire to posts with galvanised staples with the distance from the ground to the top wire no less than 1.05m. In cases where there is heavy pressure from sheep or cattle, a second line wire on top of the netting as well as an additional wire at the bottom should be added. The top wires of any fencing erected next to public access routes must consist of plain wire or an additional line of plain wire must be affixed to the outside of the posts closest to the route in question.
- Ensure that the new fencing conforms to British Standards 1722 and 4102, as amended.
- Use trees and shrubs as strainers or fencing posts, or attach wire, staples or netting to them.

Example Diagram of Post and Wire with Stock Netting

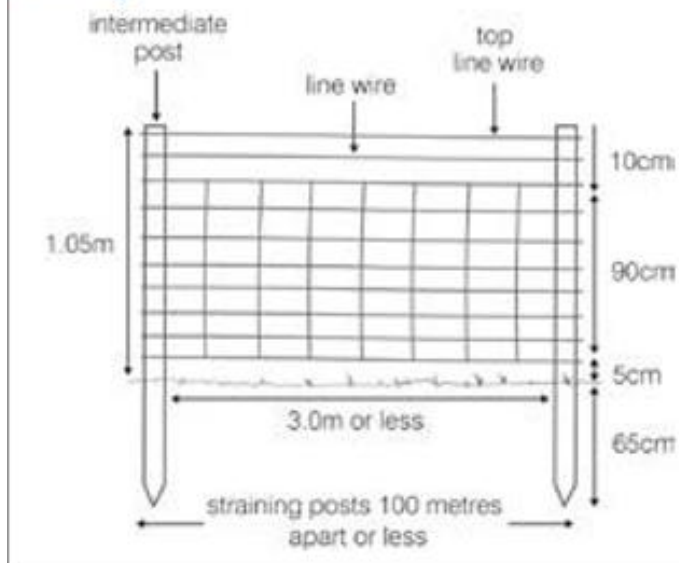

Requirements and guidance in addition to the specifications above:

- Best practice is to set the posts at least 1m into the ground to ensure stability.
- Diagonal struts must be supported with either a base plate or a suitably positioned intermediate post to prevent them splaying outwards.
- Ensure that you have the appropriate Flood Risk Activity Permit if you are planting or fencing near a main river, flood plain or flood defence structure. Alternatively, ensure you have the appropriate Ordinary Water Course Consent if you are carrying out works near an ordinary water course. What may be considered a ditch may be an ordinary watercourse, so consent may be required. As such, the permit/consent (or confirmation that a permit/consent is not needed) should be retained and made available on request. See Terms and Conditions for more details.
- Where INRS activities include the installation of access furniture such as stiles or gates on a Public Right of Way, it is your responsibility to ensure you obtain approval under Section 147 of the Highways Act, 1980, from the appropriate Highway Authority

Supplement for Rabbit Fence Netting

Item Code: D051

Payment Rate: £2.37

This option is supplementary and can only be used against the following options where they are also being installed:

D020 – Post and Rail Fence

D021 – Post and Wire Fence
D024 – Parkland Tree Guard
D071 – Post and Wire Fencing with Stock Netting

This technical note describes the minimum standard of work required in order to receive payments for ‘Supplement for Rabbit Fence Netting’. Any variation must be approved by the Welsh Government prior to starting the work.

Rabbit fencing can be specifically used to prevent damage to specific landscape features such as newly planted trees and hedgerows.

You must adhere to the following:

- Attach all wire and netting to posts with galvanised staples.
- Use galvanised wire netting at least 1.05m high, with a mesh no larger than 3cm.
- Ensure the top edge of the netting is at least 0.75m above ground level.
- Ensure that timbers, wire, netting and galvanised staples consist of new materials.
- Ensure that the netting is fastened to the fencing with the bottom edge of the netting buried in the ground to a sufficient depth to prevent rabbits burrowing underneath.
- Where required, fix strands of line wire to support the rabbit fence.
- Ensure any gates used in rabbit fences are appropriately proofed to prevent rabbit/hare access.
- Ensure that the new fence conforms to British Standards 1722 and 4102, as amended.

Do not:

- Use trees and shrubs as strainers or fencing posts, or attach wire, staples or netting to them.

Requirements and guidance in addition to the specifications above:

- Prevent rabbits burrowing underneath by ensuring that the netting is buried in the ground to a depth of 15cm and then turned outwards a further 15cm and anchored securely.
- Ensure that you have the appropriate Flood Risk Activity Permit if you are planting or fencing near a main river, flood plain or flood defence structure. Alternatively, ensure you have the appropriate Ordinary Water Course Consent if you are carrying out works near an ordinary water course. What may be considered a ditch may be an ordinary watercourse, so consent may be required. As such, the permit/ consent (or confirmation that a permit/ consent is not needed) should be retained and made available on request. See Terms and conditions for more details.

- Where INRS activities include the installation of access furniture such as stiles or gates on a Public Right of Way, it is your responsibility to ensure you obtain approval under Section 147 of the Highways Act, 1980, from the appropriate Highway Authority.

Example of Rabbit Fencing

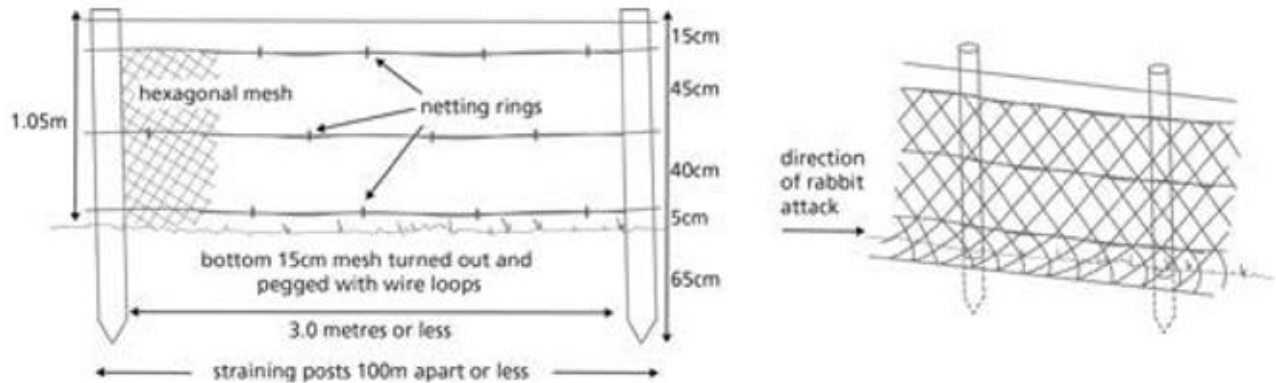

Borehole

Item code: D052

Payment Rate: £3,303.00

Borehole for the extraction of water, comprising:

- Pump, pipes, cables etc.
- Test pumping and transport.
- Any planning licenses or consents must be obtained prior to making an application.
- Water to be used predominantly for livestock / agricultural use.

Water harvesting and filtering equipment (Above ground)

Item Code: D053

Payment Rate: £800.00

Rain water harvesting and filtering systems, comprising:

- Above ground tank.
- Filtration system and associated taps and fittings.
- Minimum tank size of 10,000 litres.

- Entry filtration system. (where more than one tank is installed and linked, only one entry filtration system is required)
- Overflow diverted to a clean water drain.
- Water used for cleaning, drinking or washing, installed tank connected to a suitable water usage system.
- Water harvested from agricultural buildings and used for farm purposes.

Water harvesting and filtering equipment (Below ground)

Item Code: D054

Payment Rate: £3,600.00

Rain water harvesting system, comprising:

- Below ground tank.
- A minimum tank size 20,000 litres.
- Filtration system and associated connectors and fittings.
- Water pump.
- UV filter.
- Entry filtration system.
- Overflow diverted to a clean water drain.
- Water used for cleaning, drinking or washing, installed tank connected to a suitable water usage system.
- Water harvested from agricultural buildings and used for farm purposes.

Cover or floating cover for slurry stores (per square metre)

Item Code: D055

Payment Rate: £3:00

Floating cover over lagoon or storage tank to:

- Prevent rainwater entering the store.
- Prevent slurry-associated gas losses.
- Is flexible, durable and impermeable.
- Price per square metre.

Deer Fencing

Item Code: D057

Payment Rate: £3.98

This technical note describes the minimum standard of work required in order to receive payments for 'High Seat' and 'Deer Fencing', as specified in your contract.

Any variation from the standards set out must be approved by the Welsh Government before work commences.

Deer High Seats

- High seats must be commercially made galvanised high seats and should be used in conjunction with Deer Initiative Best Practice Guidelines. For more information on deer high seats, please see the following guidance produced by the Deer Initiative. www.thedeerinitiative.co.uk

Deer Fences

- Fences must be carried out to the specifications found in 'Forest Fencing' - www.forestresearch.gov.uk and appropriate to deer species.
- Note that where fencing across a Public Right of Way is under consideration, the Contract Holder must seek prior consent from the local Highway Authority (s.147 Highways Act, 1980) prior to constructing any fencing or associated stiles.
- Fencing timber must comprise either hardwood or pressure treated softwood. Trees and shrubs must not be used as strainers or fencing posts nor may they be used to support fencing wire, staples or netting.
- Where fencing is installed within a Schedule Ancient Monument or Registered Historic Parkland you must seek prior consent.
- Fencing timbers, line wire, netting and staples used to construct approved fence lines must always consist of new materials. The standard payments include an allowance for the dismantling, removal and safe disposal of existing derelict fences.
- All materials and construction standards must also conform to the following detailed specifications in addition to British Standards 1722 and 4102

Straining posts	3m x 15m top diameter minimum (10ft x 6")
Struts	2.75m x 10cm - 13cm top diameter round timber (9ft x 4-5")
Intermediate posts	2.75m x 8cm - 10cm top diameter round post (9ft x 3-4")
Netting	Either: High Tensile type: HT/13/190/15 Or: Light Weight High Tensile type: LHT/13/190/15 (LHT is particularly suitable for coppice coupe protection)
Top wire	1 x 12.5g high tensile plain wire
Line wires	3 x 12.5g high tensile plain wire

Staples	4cm x (1.5") 8g
Finished height	1.9m – 2m (6ft 4" – 6ft 6")

Construction

- Strainer posts to be situated at change of direction (either horizontal or vertical) or maximum 200m (ca. 600ft) on straight run. They must be dug or driven a minimum 90cm (3ft) into the ground. The strainer struts to be notched and nailed to straining posts stabilised with a sawn rail thrust plate of 50cm x 38cm x 76cm (1ft 9" x 1½" x 3"). Intermediate to be spaced at 5m (16ft 6") intervals maximum.
- The netting must be properly strained and fixed to give a maximum gap of 5cm (2") between the bottom of the net and the ground. A single top wire to be set 10cm (4") above the top of the netting. The line wires to be set such that the bottom strand runs along the bottom of the netting; the middle strand runs at a height of 1m (3ft 4") from ground level and the top strand to run along the top of the netting. All line wires to be fixed securely to the netting with pig rings or lashing rods.

Deer netting

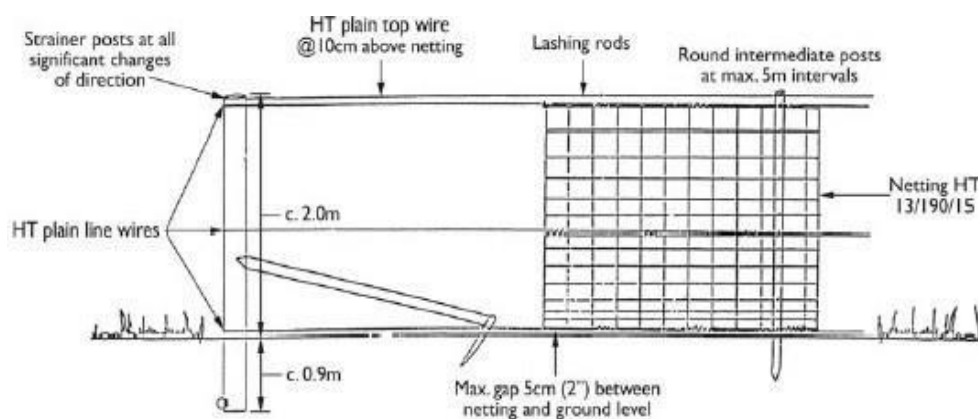

Re-Stocking

Item Code: D058 – D062
Further Information Below

This technical note describes the minimum standard of work required in order to receive payments for new planting and re-stocking options:-

D058 - Basic Re-stock >350m

D059 - Basic Re-stock 250 and 350m

D060 - Basic Re-stock <250m

D061 - Re-stocking: Native Broadleaved Trees

D062 - Re-stocking: Broadleaved Trees

Restocking is the replanting of previously felled areas with new trees and shrubs.

Timing

The planting season traditionally runs from 1st October to 30th March. At higher altitudes, restocking can be extended into April. The Scheme will have allocated a calendar year for completion. Restocking can be scheduled straight after felling or a few years later; this depends on the site but is a good idea to complete the restocking before rank vegetation develops.

Ground Preparation

Trees can be planted without any site preparation if the site is very clean but generally some work will be beneficial. Removal/redistribution of brash after felling may be required. There may be a thick layer of conifer needles or vegetation; this should be disturbed to expose the soil to allow restocking of the whole site. If the area is wet, then drainage and/or raised planting mounds may need to be created to allow restocking. On small sites these operations can be done by hand but a tracked excavator is generally the most practical machine for these operations on large sites. It is critical that any dense vegetation is controlled before restocking as it is easier and cheaper to do before, rather than after restocking.

Tree Species

The species and percentages of trees to be planted will be specified in your contract, if any clarification is required then you should contact Welsh. Factors such as different soil types and tree growth characteristics are taken into account when selecting species. When planting mixtures, different tree species should be planted throughout the restocking area in single species groups of 5-25 trees. Group size should also be taken into account.

*Due to Ash dieback disease (*Chalara fraxinea*), no ash should be included in any planting mix for either woodlands or when establishing or restoring hedgerows. For slower growing species such as oak - plant a group of sufficient size to ensure that the trees are not shaded out by faster growing species.*

Buying Trees

When buying large quantities of trees, a specialist tree nursery will be the best place. For the woodland elements of the scheme, transplants will be used rather than whips or standards.

Nursery trees come in different forms;

- **Bare Root** - trees are lifted from the ground with bare roots and packaged together in bundles. Bare rooted stock are the most regularly used for restocking, but need to be stored and handled carefully.
- **Cell Grown (Plugs)** - grown in plastic trays which create a narrow plug of fine roots and soil. These trees allow the planting season to be extended at either end as the roots can grow within the soil plug and avoid damage during planting.
- **Pot Grown** - grown in an individual plant pots and are usually reserved for larger trees and some shrub or ornamental species such as holly. These are more expensive and bulky but flexible like cell grown plants.

Tree Size

Available sizes are generally between 10 and 60cm in height. Nurseries classify trees in different bands for example 20-40cm or 40-60cm. For most restocking, a robust tree with a good root system of size 40-60cm will be suitable.

Tree Handling

Try to be on hand when plants arrive so that you can ensure they are in good physical condition.

Keep the roots covered at all times before planting to prevent damage and drying out. Whilst cold is unlikely to be harmful, hot sun and any form of drying such as an east wind, can very quickly cause damage or kill the plants. If immediate planting is not possible, dig a trench before delivery and store plants in this with the roots covered so they are kept moist and cool. Protect the plants from animals, including rabbits and hares.

Tree Spacing

For restocking, tree numbers will be expressed as a figure/Ha:-

1600 trees/Ha = 2.5m spacing between trees (Only 632 - Restocking: Riparian zones)
2,500 tree/Ha = 2m spacing between trees (All restocking operations).

Planting native broadleaved species can be have more varied spacing, closer in some parts and wider in others, as long as the overall tree density is the same.

If your site includes un-mappable open ground, tree spacing should be reduced to take this into account and ensure you have the specified number of trees required per hectare.

Tree shelters

Larger areas of restocking, especially conifer restocking, are usually planted without any further protection most restocking sites have rabbits, hares and voles and it is advisable to protect broadleaves with tree shelters to prevent damage. There are many different types of tree guards available, from light spiral guards secured with canes, to solid plastic shelters which require stakes and ties. Tree shelters can boost the early growth of trees, make maintenance easier and ensure the trees are not damaged by mammals or bracken.

Protection against Livestock

Restocking sites must be protected from domestic animals and deer by using appropriate boundary fencing

Protection against Insects

Insect browsing can occur on new planting sites, but is less common and doesn't usually need to be considered.

On restocking sites the large pine weevil (*Hylobius abietis*) is the most common pest of young trees. It breeds in the stumps of conifers, but is quite mobile and feeds on trees and vegetation of many types. Losses can be substantial if the conditions are right, so a control strategy needs to be in place.

Expert advice should be sought if a problem is likely. There are a range of physical, biological and chemical controls available. The most practical is likely to be over spraying of the trees with an approved insecticide, possibly supplemented by using trees pre-treated with insecticide at the nursery. There are obvious environmental issues related to the use of insecticides and these need to be balanced against the other objectives. Only properly chemical licensed products can be used and applied by qualified operators.

Maintenance of trees and shrubs

Until the trees have grown large enough to grow on without intervention, they will need to be maintained to ensure 100% survival of the trees. The most important period is the three years after planting, but in poorer conditions or with ineffective maintenance it can stretch out to five or more years. The better the quality of the initial planting, protection and maintenance, the more likely that the trees will establish quickly.

Replacement trees (Beating Up)

A restock site should be assessed for losses towards the end of the summer annually. Any dead trees should be replaced in the following autumn or spring. Look for any pattern to the losses, in terms of particular areas and species. If losses are greater than 10-15% and there is no obvious cause, you should consult your Woodland Advisor for advice.

Weeding

Weed control around trees is crucial, as competition for water and nutrients is most damaging when trees have yet to develop extensive root systems. Restocking before weeds have re-established strongly, can minimise the work required.

Tall vegetation like bracken or bramble can cause physical damage to the trees and cutting by hand or mechanically is normally required, although some overall spraying of bracken is possible. Cutting or strimming of grass simply makes it more vigorous. Spot weeding with a suitable chemical is the most effective method of control. Only properly licensed chemical products can be used and applied by qualified operators. In some instances plastic, cardboard or woven mats can be used where chemical weed control is not possible, such as organic farms.

Guards and Shelters

These need to be checked regularly to make sure they are secure. Vegetation will often grow up into tubes and guards and tubes need to be kept in contact with the ground to avoid rabbits and small mammals' access to the stems. Although many products are biodegradable, they can have a negative effect on the growth and stability of the trees if left and should be removed as soon as they are not required.

Basic Re-stock > 20ha > 350m

Item Code: D058

Payment Rate: £1,900.00

You must also refer to the detailed re-stocking requirements forming part of this contract which are either shown at the start of this section 'Technical Specifications for Capital Works' or in the Contract Schedule.

This technical note describes the minimum standard of work required.

Restocking Requirements

- A minimum of 10% of compartment area must be planted with broadleaved tree species.
- The remaining area of the compartment (maximum of 90%) can be planted with broadleaved species, conifer species or a mixture of both. There must be a minimum of two different species planted with no one species exceeding 65% of the compartment.
- The area of shrub species (e.g. hazel) within the compartment should not exceed 10%. Shrub cannot contribute towards the minimum area of broadleaved tree species to be planted.
- A minimum of 2500 stems per hectare must be planted and be alive at the end of the 10 year maintenance period or canopy closure has been achieved.

Basic Re-stock > 20ha >< 250 and 350m

Item Code: D059

Payment Rate: £1,900.00

You must also refer to the detailed re-stocking requirements forming part of this contract which are either shown at the start of this section 'Technical Specifications for Capital Works' or in the Contract Schedule.

This technical note describes the minimum standard of work required.

Restocking Requirements:

- A minimum of 10% of site area must be planted with broadleaved tree species.
- The remaining area of the compartment (maximum of 90%) can be planted with broadleaved species, conifer species or a mixture of both. A minimum of three different tree species must be planted, with no one species exceeding 65% of the compartment.
- The area of shrub species (e.g. hazel) within the compartment should not exceed 10%. Shrub cannot contribute towards the minimum area of broadleaved tree species to be planted.
- A minimum of 2500 stems per hectare must be planted and be alive at the end of the 10 year maintenance period or canopy closure has been achieved.

Basic Re-stock <5ha < 250m

Item Code: D060

Payment Rate: £2,300.00

For restocking compartments where more than 50% of the compartment is located below 250 metres above sea level (e.g. 1.4 ha (54%) of a compartment is below 250 metres and 1.2 ha (46%) is above 250 metres).

You must also refer to the detailed re-stocking requirements forming part of this contract which are either shown at the start of this section 'Technical Specifications for Capital Works' or in the Contract Schedule.

This technical note describes the minimum standard of work.

Restocking Requirements:

- A minimum of 10% of compartment area must be planted with broadleaved tree species.
- The remaining area of the compartment (maximum of 90%) can be planted with broadleaved species, conifer trees or a mixture of both. There must be a minimum of three different tree species planted, with no one species should exceed 65% of the compartment.

- No more than 40% of the compartment can be planted with Sitka Spruce.
- The area of shrub species (e.g. hazel) within the compartment should not exceed 10%. Shrub cannot contribute towards the minimum area of broadleaved tree species.
- A minimum of 2500 stems per hectare must be planted and be alive at the end of the 10 year maintenance period or canopy closure has been achieved.

Re-Stocking: Native Broadleaved Trees

Item Code: D061

Payment Rate: £2,770.00

For restocking (replanting) of previously felled compartments with a mixture Native Broadleaved Trees species.

This Capital Works option requires the whole site to be planted with a mixture Native Broadleaved Trees species. The mix should be site native and largely conform to habitat types listed at section 7 of the Environment (Wales) Act 2016 (Wales Biodiversity Partnership website). These reflect previous Habitat Action Plan types such as upland oak woods and lowland mixed deciduous woodland. However local conditions may necessitate some variation from these. Further information on species mix for these habitats can be found at on the Forest Research website.

You must also refer to the detailed re-stocking requirements forming part of this contract which are either shown at the start of this section 'Technical Specifications for Capital Works' or in the Contract Schedule.

This technical note describes the minimum standard of work required.

Restocking Requirements:

- This Capital Works option requires the woodland compartment to be planted with a mixture of Native Broadleaved Trees species which must be appropriate to the area.
- The area of shrub species (e.g. hazel) within the compartment should not exceed 20%. Technical Specifications for Capital Works

Re-Stocking: Broadleaved Trees

Item Code: D062

Payment Rate: £2,770.00

For restocking (replanting) of previously felled compartments with a mixture native broadleaved trees and non native broadleaved trees.

You must also refer to the detailed re-stocking requirements forming part of this contract which are either shown at the start of this section 'Technical Specifications for Capital Works' or in the Contract Schedule.

This technical note describes the minimum standard of work required.

Restocking Requirements:

- A minimum of 80% of the site must be planted with native broadleaved trees species.
- The remaining 20% can be planted with either native or non native broadleaved trees species.
- The area of shrub species (e.g. hazel) within the compartment should not exceed 20%.
- A minimum of 2500 stems per hectare must be planted and be alive at the end of the 10 year maintenance period or canopy closure has been achieved.

Bramble/Scrub Control - Hand Knapsack Spraying

Item Code: D063

Payment Rate: £290.00

This technical note describes the minimum standard of work required in order to receive payment for control of 'Bramble / Scrub Control - Hand Knapsack Spraying', as specified in your Contract.

Bramble is a very common, successful, native species that occurs in a wide variety of habitats throughout Britain including woodlands, heaths, dunes, mires and grassland. Several features may explain the success of bramble: it can survive long periods in the seed-bank; spreads vigorously by vegetative growth; is semi-evergreen, in mild winters the leaves persist on first year canes; can be spread long distances by birds. In favourable conditions it can grow to produce dense thickets that can have adverse competitive effects on other vegetation.

Where agreed with the Welsh Government, chemical control may be carried out using a knapsack sprayer. This method should not be used in areas where scrub or bramble exceeds waist height as coverage and ultimately control, will be impaired.

The use of any chemical other than Glyphosate should be agreed beforehand with the Welsh Government and in all cases a chemical must have a label recommendation for use on bramble and for the intended method of application. All manufacturers label recommendations regarding application of the herbicide, should be strictly adhered to.

Use of Herbicides

In all cases the herbicide used must have a label recommendation for your intended use, and for the intended method of application.

You are advised to follow the recommendations in the 'Green Code' (Approved Code of Practice for the Safe Use of Pesticides on Farms and Holdings, MAFF, 1998).

Scrub Clearance (Mechanical)

Item Code: D065

Payment Rate: £227.00

This technical note describes the minimum standard of work required in order to receive payment for 'Scrub Clearance - Mechanical', as specified in your Contract. Where there are local traditional methods or styles which vary from this standard these can be used, but any significant variation must be approved by the Welsh Government prior to starting the work.

Payment can be made towards the cost of scrub clearance where it has been agreed and included in your Contract.

Scrub consists of woody shrubs or trees such as hawthorn, willow, gorse and birch which are pioneer or opportunist species. Scrub needs to be controlled and/or removed where it threatens to replace more valued wildlife habitats, causes damage to archaeological remains, or obscure routes used for public access.

Whilst capital payments are available for scrub clearance, many areas of scrub are also of significant landscape and wildlife value in their own right.

Scrub Cutting and Removal

To protect nesting birds you must not clear scrub in the bird nesting season 1 March to 31 August. You must seek advice from the Welsh Government if protected species such as badger are likely to be present.

Cut scrub at ground level leaving no protruding stumps. Alternatively remove small seedlings by pulling. Removal of large stumps followed by bulldozing is not acceptable. The burning of standing scrub is only to be attempted following agreement from the Welsh Government.

When carrying out partial scrub clearance (on the edge of a heath land or when breaking up a dense stand of scrub into smaller blocks), ensure that the scrub edges retain a natural and uneven appearance. Small bays and other sheltered locations are particularly valuable for butterflies and other wildlife.

Cut material should be removed from the site unless the Welsh Government agrees otherwise or the work is being undertaken to manage a woodland. In such circumstances, cut material should be stacked carefully under the remaining scrub

patches where it can be left to decay and provide additional cover for wildlife. Alternatively, cut material may be burned in previously agreed locations well away from standing scrub and trees.

Use of Herbicides

After cutting, many species will respond by sending out new shoots rather than being killed outright. This growth may be controlled by grazing pressure or by mowing, but it may be necessary to treat either the cut stump or the bushy re-growth with a suitable herbicide.

Any chemical used must have a label recommendation for treating scrub (either re-growth or cut stumps) and for the intended method of application. All manufacturers label recommendations regarding application of the herbicide should be strictly adhered to.

Follow the recommendations of the 'Green Code' (Approved Code of Practice for the safe use of Pesticides on Farms and Holdings, MAFF 1998).

Scrub Clearance on Archaeological Sites

Archaeological features such as barrows, forts, deserted medieval villages or even simple boundary banks are often best preserved under a cover of grass or heath. A light grazing or mowing regime is all that is required to maintain this cover. You should ensure that earthworks are not disturbed and that a cover of grass or heath is quickly re-established.

Invasive Plant Species Control

Item Code: D066

Payment Rate: £1,179.00

This technical note describes the minimum standard of work required in order to receive payment for control of 'Invasive Plant Species Control', as specified in your Contract. This includes species such as 'Japanese Knotweed', 'Himalayan Balsam' and 'Giant Hogweed'.

Exotic plants such as 'Japanese Knotweed', 'Himalayan Balsam' and 'Giant Hogweed' were introduced to Britain in the 19th Century, mainly for ornamental reasons. These have now become widespread, creating problems by overwhelming native species and in some cases causing physical damage to stream sides and river banks.

'Japanese Knotweed' is by far the most common and invasive of these species. It is a swift growing perennial plant, which overruns other vegetation and can cause severe damage to embankments, walls and paving. Dense growths can be 2m high in summer whilst in winter the plant dies back to leave an unsightly mass of dead brown stems.

The plant spreads in three main ways:

- By underground stems (rhizomes) from which new shoots arise and spread into the surrounding soil.
- By movement of pieces of rhizome in the soil during earth moving operations. Fly tipping of soil and builder's rubble is a major cause of the plant's rapid spread over large parts of the country.
- By the erosion of soil on riverbanks and the movement of stems and rhizomes downstream to new sites.

It is essential that the spread of 'Japanese Knotweed' is controlled and the plant prevented from establishing itself within previously clear areas.

In general, 'Japanese Knotweed', 'Himalayan Balsam' and 'Giant Hogweed' can all be controlled by similar methods. Treatment involves a combination of mechanical and chemical techniques. Purely mechanical methods such as cutting, pulling and grazing may be preferred in certain circumstances but such work cannot be funded as part of the capital works programme unless all details are agreed in advance by the Welsh Government.

A systematic work program to ensure that the control is effective may need to be agreed. You should take extra care when treating 'Giant Hogweed' as the plant can cause severe skin irritation.

Working Methods

Payment includes provision for initial cutting plus three treatments with a suitable chemical. The method and timing of treatments varies slightly for each species.

Japanese Knotweed

- During the winter preceding your intended chemical treatment, clear all the dead plant material from the area to be treated.
- Chemical control works best on Japanese Knotweed when it is around a height of 1.5m. Plants any higher than this should be cut back to ground level using a grass mower or brush cutter and allowed to re-grow to a suitable height for treatment. (This will take around 3 - 4 weeks).
- Spray or weed-wipe with an appropriate herbicide between May and September.

Himalayan Balsam

Apply an appropriate herbicide in late spring and before the end of June. It is important to do this before the plants have flowered and set seed.

Giant Hogweed

Apply an appropriate herbicide from March onwards, when the plant is between 0.5m and 1.5m high.

Plants taller than 1.5m should be cut down and allowed to re-grow to a height of 0.5m - 1.5m before being sprayed. Suitable protective clothing should be worn when working near Giant Hogweed. All cuttings must be destroyed as the plant can cause skin irritation.

Use of Herbicides

In all cases the herbicide used must have a label recommendation for your intended use, and for the intended method of application. All manufacturers label 'Follow the recommendations in the Green Code' recommendations, should be strictly adhered to. Approved Code of Practice for the Safe Use of Pesticides Application using weed wipes is recommended, as this (on Farms and Holdings, MAFF 1998) avoids spray drift, but spray application using a knapsack sprayer with nozzle control is also acceptable.

When working near watercourses, use an herbicide which is approved for this use and follow the manufacturer's instructions.

Rhododendron Control

Item code: D064 - Rhododendron Control (Under 1.5m Tall)

Payment Rate: £3,882.60

Item Code: D068 - Rhododendron Control (Between 1.5 To 2.5m Tall)

Payment Rate: £5,129.10

Item Code: D067 - Rhododendron Control (Over 2.5m Tall)

Payment Rate: £7,461.13

This technical note describes the minimum standard of work required in order to receive payment for 'Rhododendron Control - Under 1.5m Tall, Over 2.5m Tall and Between 1.5 and 2.5 m Tall', as specified in your Contract.

Where there are local traditional methods or styles, which vary from this standard, these may be used, subject to receiving prior approval from the Welsh Government for any significant variation.

Rhododendron (*Rhododendron ponticum*) is an attractive shrub when in full flower and was widely planted in many gardens in the past. It is also an extremely invasive plant, and can rapidly colonise a range of habitats including woodlands, heathlands and bogs. Having around 20,000 seeds per gram, they are easily spread by the wind. Very few native birds or animals live within dense stands of rhododendron and

most plants are unable to survive and flourish underneath the dense and heavily shaded canopy. Removal of rhododendron is often essential if further habitat damage is to be prevented.

Capital payments are available to cover the cost of rhododendron control where an agreed management plan has been drawn up. The payment is designed to cover the cost of the initial clearance of the site followed by herbicide treatment of re-growth in subsequent years, or initial stem treatment followed by subsequent spot treatment of any shoots missed. In addition, it is likely that seedlings will appear for several years following the initial clearance. These will need to be pulled by hand to prevent re-establishment.

Control Methods

An effective programme of control is likely to involve a combination of the following methods, depending on the site and size of plants.

Cutting

Plants that are taller than 1.5 metres and areas where the rhododendron is too extensive to spray with herbicide, should be cut down to a stump of no more than 10cm high and herbicide applied to the cut stumps on the same day as severance, ideally within a few hours. The cut material should be stacked and left to rot, or burnt. Any fire should be sufficiently far away from standing trees to avoid any possibility of the crown and bark being scorched.

At certain times of year the cut-stump treatment is not effective. The method should be avoided between early February and mid-April (when sap is rising) and also between mid-August and late October.

After a period of 18 to 24 months or when there is sufficient re-growth, this should be sprayed as outlined below (see spraying with herbicide). Any re-growth should be sprayed again the following year.

Stem Treatment

Stem treatment, or stem injection is a very simple and effective method, especially for large few-stemmed bushes with stems of 3cm or more diameter. This involves drilling 8 to 12mm diameter holes as near as vertically possible at the base of each stem. Multiple holes at 10cm intervals are needed if the stem is large. The holes should be sufficiently deep to take 1ml of herbicide solution.

The herbicide used should be 20% aqueous solution of glyphosate (Roundup Biactive or equivalent) with a strong vegetable dye. Large bushes should be dosed with 50% aqueous solution of roundup. Each hole should be filled using a suitable applicator, such as a spot gun or veterinary injector. All treated plants should be marked with spray paint or a suitable method for identification, to avoid missing or double treatment. For optimum effect, due to sap rise, treatment should not take place between March and early June.

This treatment must be followed up by manual cutting once the bush is dead. Any re-growth after 12 to 18 months should be sprayed as outlined below.

Follow up treatment (Spraying with Herbicide and Hand Pulling)

Whichever method used, follow up treatment is needed. Seedlings can survive in the soil for 3 to 5 years. Therefore, after the initial removal/treatment, a second spraying and hand-pulling visit is essential.

Plants under 1.5 metres high and where it is possible to reach all of the leaves with a knapsack sprayer may be treated with an appropriate herbicide. It is essential that the spray covers all of the foliage on both sides. A second application may be necessary.

Spraying can take place throughout the year, but March to October is optimal. Spraying should not be carried out in windy conditions or if rain is expected within 10 hours.

In all cases the herbicide used must have a label recommendation for use on rhododendron and for the intended method of application. All manufacturers label recommendations should be strictly adhered to. Follow the recommendations in the 'Green Code' (Approved Code of Practice for the Safe Use of Pesticides on Farms and Holdings, MAFF 1998).

Any plants that are small enough (60cm or less) can be pulled up by hand and either be collected and disposed of safely or if left on site, to avoid re-rooting, have all the soil knocked off the roots and left in a stable position off the ground to dry out.

By underground stems (rhizomes) from which new shoots arise and spread into the surrounding soil.

By movement of pieces of rhizome in the soil during earth moving operations. Fly tipping of soil and builder's rubble is a major cause of the plant's rapid spread over large parts of the country.

By the erosion of soil on riverbanks and the movement of stems and rhizomes downstream to new sites.

During the winter preceding your intended chemical treatment, clear all the dead plant material from the area to be treated.

Chemical control works best on Japanese Knotweed when it is around a height of 1.5m. Plants any higher than this should be cut back to ground level using a grass mower or brush cutter and allowed to re-grow to a suitable height for treatment. (This will take around 3 - 4 weeks).

Mixed leys (Also referred to as multi species or herbal leys)

Item Code: D069

Payment Rate: £324.00 / ha

Establish a mixed ley, comprising minimum 5 grass species, 3 legume species and 3 herb species. (Species not individual varieties within species)

- Minimum seed rate 25 kg / ha.
- Maximum Ryegrass content 6 kg / ha
- Maximum other grass seed content 9 kg / ha (Maximum total grass seed content 15 kg / ha)

Minimum requirements:

- Soil test carried out or undertaken in the 3 years prior to application. (Minimum requirement is to test for the P, K and pH levels). Action taken to rectify any immediate deficiencies identified in P, K and pH levels prior to establishment.
- Only use certified seed at the recommended seed rate.
- The choice and mix of species must be appropriate to the location.
- Minimum area of 1 ha. (You can split the minimum 1ha area across one or more land parcels, provided the area is at least 0.1ha).
- Mixed ley to be retained for a minimum 3 years from the date of establishment.

Establishment:

- Do not plough or cultivate land before 1 March.
- Sow between 1 April and 31 August.
- Crop can be established through ploughing, traditional cultivations and drilling, minimum tillage or direct drilling.
- Mix the seed in the hopper immediately before sowing a seed mix to stop an uneven spread of crops.
- Seed can be broadcast or drilled, but no deeper than 1cm.
- Roll after sowing to retain moisture.
- If using minimum tillage or direct drilling, the use of an appropriate, approved herbicide to spray off an existing grass sward is required. (This requirement not applicable for farmers certified as organic).
- Once established, do not use pesticides, except herbicides to spot treat or weed-wipe injurious weeds* or invasive non-native species, soft and hard rush, nettles or bracken.
- Do not use inorganic fertilisers containing nitrogen following establishment until the following spring. (It is recommended that nitrogen fertiliser use is avoided to achieve maximum agronomic and environmental benefits from the diverse ley.)
- Maintain a 1m grass buffer strip adjacent to a hedge, earth bank or watercourse.
- Established sward to be managed to maintain sward diversity, to encourage the flowering and seeding of the mixed ley and to avoid poaching.
- A record of all field activity, including sowing date, evidence of fertiliser and pesticide applications and grazing or cutting dates should be kept for inspection.
- <https://gov.wales/control-injurious-harmful-weeds>

Cover Crops

Item Code: D070

Payment Rate: £124.00 / ha

Description

Establish an unsprayed cover crop following autumn harvesting of cereals, maize or horticultural crop where soil, after harvesting, is ordinarily left bare or stubble retained.

Benefits

The crop will:

- Reduce nutrient loss and soil erosion during the winter.
- Improve soil structure by breaking up compaction in the soil and encouraging water uptake.
- Increase soil organic matter, structure and mineral composition through aeration and locking in nitrogen, making it available to the following spring sown crop.
- Provide winter shelter and feeding areas for farmland birds and small mammals.

Minimum requirements:

- Minimum total area of 1 ha (you can split the minimum 1ha area across one or more land parcels).
- No artificial fertiliser, manure, or slurry to be applied between harvesting the preceding crop and 15 February in the following year.
- Soil test (minimum P, K, and pH) undertaken on field/fields, or undertaken in the 12 months prior to application. The soil test will inform future action required to rectify any deficiencies identified in P, K and pH levels prior to next crop being established.
- Seed mixture to include a minimum of 2 crop species which are suitable for late season germination and will cover the ground quickly before the winter, such as: Radishes, Mustard, Phacelia, Rye, Vetches, Italian ryegrass, Westerwolds ryegrass, rape, brassicas etc.
- Italian ryegrass, Westerwolds ryegrass and Rye cannot be grown in combination.
- Where Italian or Westerwolds ryegrass is included in the mixture, the seed rate for these species should not exceed 15kg / ha.
- Use certified seed sown at recommended seed rate, taking into account the species combination. (Maximum seed rate for Italian and Westerwolds ryegrass to be observed).

- The inclusion of perennial ryegrass, wheat, barley, oats or triticale in the mixture is not eligible.

Establishment:

- Crop to be sown as soon as possible once previous crop being harvested.
- Established by direct drilling or broadcast with light cultivations.
- Do not plough and avoid significant cultivations that will disturb soil structure.
- Once the previous crop has been harvested, do not use pesticides.
- Maintain a minimum 1m grass buffer strip adjacent to a hedge, earth bank or watercourse.
- Cover crop must remain in situ until 15 February of the following year, at which time it can be grazed, cut or desiccated prior to ground preparation for the following crop.
- Where the crop is grazed, the grazing should be managed to avoid any soil run-off during the period from grazing to establishing the following crop.
- A record of all field activity must be kept for submission and inspection.

Post and Wire Fencing with Stock Netting

Item Code: D071

Payment Rate: £8.33

This technical note describes the minimum standard of work required in order to receive payment for 'Post and Wire Fencing with Stock Netting'. Any variation must be approved by the Welsh Government prior to starting the work.

You must adhere to the following:

- Ensure that you have obtained, and adhere to any licences, consents or permissions that are needed.
- Use fencing timber comprising either hardwood or pressure treated softwood.
- Ensure that timbers, wire, netting and galvanised staples consist of new materials.
- Use straining posts that are a minimum of 12.5cm cross section and at least 2m long. Straining posts must be set into the ground at a sufficient depth to ensure stability. Straining posts must be placed at either end of the fence line and at centres of 100m or less, as well as at every horizontal or vertical change of direction.
- Attach struts at each end of the fence line and at all changes of slope and direction. Struts must have a top diameter of at least 6.5cm and must be

supported to prevent them splaying outwards. Use intermediate posts that are at least 6.5cm diameter (round posts and sawn timber) and at least 1.7m long. Half round posts are acceptable provided they measure at least 6.5cm from the midpoint of the sawn side to the midpoint of the round side. Intermediate posts must be set at centres of 3m or less.

- Attach netting to posts with galvanised staples.
- Attach wire to posts with galvanised staples with the distance from the ground to the top wire no less than 1.05m. In cases where there is heavy pressure from sheep or cattle, a second line wire on top of the netting as well as an additional wire at the bottom should be added. The top wires of any fencing erected next to public access routes must consist of plain wire or an additional line of plain wire must be affixed to the outside of the posts closest to the route in question.
- Ensure that the new fencing conforms to British Standards 1722 and 4102, as amended.
- Use trees and shrubs as strainers or fencing posts, or attach wire, staples or netting to them.

Example Diagram of Post and Wire with Stock Netting

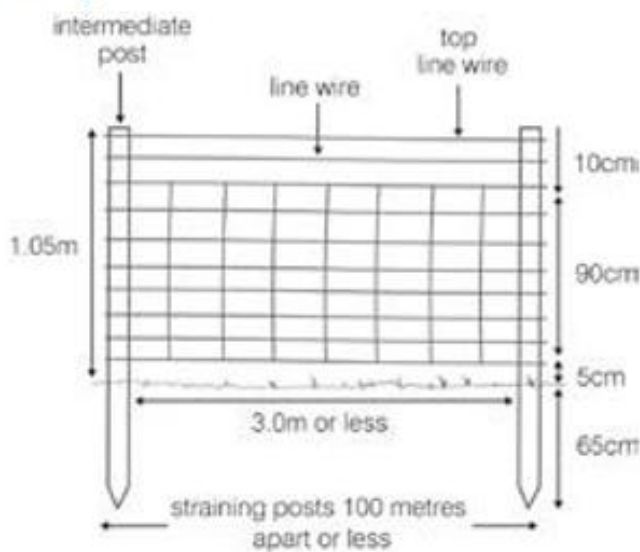

Requirements and guidance in addition to the specifications above:

- Best practice is to set the posts at least 1m into the ground to ensure stability.
- Diagonal struts must be supported with either a base plate or a suitably positioned intermediate post to prevent them splaying outwards.
- Ensure that you have the appropriate Flood Risk Activity Permit if you are planting or fencing near a main river, flood plain or flood defence structure. Alternatively, ensure you have the appropriate Ordinary Water Course Consent if you are carrying out works near an ordinary water course. What may be considered a ditch may be an ordinary watercourse, so consent may

be required. As such, the permit/consent (or confirmation that a permit/consent is not needed) should be retained and made available on request. See Terms and Conditions for more details.

- Where INRS activities include the installation of access furniture such as stiles or gates on a Public Right of Way, it is your responsibility to ensure you obtain approval under Section 147 of the Highways Act, 1980, from the appropriate Highway Authority